

# PARTS CATALOG



Rapco, Inc.  
445 Cardinal Lane  
Hartland, WI 53029  
262.367.2292 phone  
262.367.7158 fax  
[www.rapcoinc.com](http://www.rapcoinc.com)



*For Reference Only. Please refer to individual  
FAA-PMA Supplements for Installation Eligibility*

**RAPCO, inc.**  
**REPLACEMENT AIRCRAFT PARTS CO.**



# Complete Pneumatics Application Guide

**New FAA-PMA Approved  
Dry Air Pumps,  
Filters, Regulators**

**FAA Approved Overhauled  
Dry Air Pumps**



**Section 1: Type Certified Aircraft**

**Section 2: Dry Air Pump Cross Reference for Kit Plane and Experimental Aircraft Engines**

**Section 3: Beech Rudder Boost Filter**

For reference only. For installation eligibility refer to the FAA-PMA Supplement.

Some aircraft models or particular serial numbers may have applications other than those listed in this guide.

Consult the appropriate aircraft parts catalogue, maintenance manual or equipment list when selecting a part for installation.

To convert an Airborne or Parker part number to RAPCO, on new dry air pumps add RAP to the beginning of the number, on other new Rapco products add RA.

***RAPCO, inc.***

**REPLACEMENT AIRCRAFT PARTS CO.**

445 Cardinal Lane

Hartland, Wisconsin 53029 USA

For a list of Distributors, please click on the document on the home screen or visit [www.rapcoinc.com](http://www.rapcoinc.com)





**PNEUMATICS APPLICATIONS**

**RAPCO Inc. FAA-PMA Approved Dry Air Pumps, Filters, Regulators, and Manifold Check Valves  
Overhauled Dry Air Pumps - FAA / EASA / CAA Approved Data with Dual Release on FAA Form 8130-3**

This Application Guide is to be used for reference only.

When selecting a part for installation consult the appropriate aircraft parts catalogue for approved data.

RAPCO FAA / EASA approved dry air pumps have RAP added to the beginning of the original equipment part number, all other RAPCO pneumatic products have RA.

[Refer to the FAA-PMA Supplement for installation eligibility.](#)

Section 1: Type Certificated Aircraft

Section 2: Dry Air Pump Application Guide for Kit Plane and Experimental Aircraft Engines

Section 3: Beech Rudder Boost Filter

Section 1:

**Type Certificated Aircraft**

Aircraft Manufacturer Model / Serial Number / Option	Engine Manufacturer & Model	Dry Air Pump			Filters	Regulator	Check Valve
		New RAPCO	Overhauled RAPCO	Overhauled OEM			
<b>Aero Commander / Gulfstream / Rockwell / Twin Comander</b>							
500	LYC O-540-A	RAP215CC	RAP215CC-OH	211CC	RA-B3-5-1		
500-A	TCM IO-470-M	RAP216CW	RAP216CW-OH	212CW	RA-B3-5-1		
500-B, -U	LYC IO-540-B, -E	RAP215CC	RAP215CC-OH	211CC	RA-B3-5-1		
500-S	LYC IO-540-E	RAP215CC	RAP215CC-OH	211CC			
520	LYC GO-435-C	RAP216CW	RAP216CW-OH	212CW			
700 Non Deice	LYC TIO-540-R				RA2J4-7, RA-D-9-14-5		
700 Deice	LYC TIO-540-R				RA2J4-7, RA-D-9-14-5		
<b>Aeronca - see American Champion</b>							
<b>Aerospatial - see Socata</b>							
<b>Aerostar / Ted Smith Aerostar / Piper Aerostar</b>							
360, 400	LYC O-360-D, -E	RAP215CC	RAP215CC-OH	211CC	RA2J4-4		
600 thru 701P - see Piper PA-60	LYC IO-540-G, -P	RAP241CC-13	RAP241CC-13-OH		RA-D-9-14-5, RA2J4-4		
PA-60-600, -601 Aerostar Non Deice							
PA-60-601P, PA-60-602P Non Deice	LYC IO-540-P, -A	RAP241CC-13	RAP241CC-13-OH		RA2J4-4, RA-D-9-14-5		
PA-60-601P, PA-60-602P Deice	LYC IO-540-P, -A	RAP441CC-17	RAP441CC-17-OH		RA2J4-4, RA-D-9-14-5		
PA-60-700P	LYC TIO-540-U	RAP441CC-17 (Left)	RAP441CC-17-OH		RA2J4-4, RA-D-9-14-5		
	LYC LTIO-540-U	RAP442CW-20 (Right)	RAP442CW-20-OH				
<b>American Aviation / American General - see Grumman</b>							
<b>American Champion / Bellanca / Champion / Aeronca</b>							
7AC	LYC O-235-C	RAP215CC	RAP215CC-OH	211CC			
7GC, 7HC	LYC O-290-D	RAP215CC	RAP215CC-OH	211CC			
7GCA, 7GCB, 7KC, 7GCBA, Citabria	LYC O-320-A	RAP215CC	RAP215CC-OH	211CC			
7ECA, Champ	TCM O-200-A	RAP215CC-9	RAP215CC-9-OH	211CC-9			
	LYC O-235-C	RAP215CC	RAP215CC-OH	211CC			
7GCAA, 7GCBC	LYC O-320-A, -C	RAP215CC	RAP215CC-OH	211CC			
	LYC O-235-C	RAP215CC	RAP215CC-OH	211CC			
7KAB, 8KAB, Decathlon	LYC IO-320-E	RAP215CC	RAP215CC-OH	211CC			
8GCBC, Scout	LYC O-360-C	RAP215CC	RAP215CC-OH	211CC			
<b>Aviat</b>							
A1C-160 Husky	LYC O-320-D2A	RAP215CC	RAP215CC-OH	211CC	RA1J7-1, RA-B3-5-1	RA2H3-23	
A1C-180 Husky	LYC O-320-A1P	RAP215CC	RAP215CC-OH	211CC	RA1J7-1, RA-B3-5-1	RA2H3-23	
A1C-200 Husky	LYC IO-360-A1D6	RAP215CC	RAP215CC-OH	211CC	RA1J7-1, RA-B3-5-1	RA2H3-23	
<b>Beech / Beechcraft / Raytheon / Hawker Beechcraft / Textron</b>							
19A,	LYC O-320-E	RAP215CC	RAP215CC-OH	211CC	RA-B3-5-1	RA2H3-2	
A23-19 Musketeer							
SN. MB1 - MB480							
SN. B19, MB481 - MB701	LYC O-320-E	RAP215CC	RAP215CC-OH	211CC	RA-B3-5-1	RA2H3-2	
SN. MB702 - MB865	LYC O-320-E	RAP215CC	RAP215CC-OH	211CC	RA-B3-5-1	RA2H3-12	
SN. M19A	LYC O-320-E	RAP215CC	RAP215CC-OH	211CC			
23 Musketeer SN. M1 - M554	LYC O-320-D	RAP215CC	RAP215CC-OH	211CC	RA-B3-5-1	RA2H3-2	
A23, A23A SN. M555 - M1094	TCM IO-346-A	RAP216CW	RAP216CW-OH	212CW	RA-B3-5-1	RA2H3-2	
A23-24 SN. MA1 - MA363	LYC IO-360-A	RAP215CC	RAP215CC-OH	211CC		RA2H3-2	
B23 SN. M1096 - M1284	LYC O-360-B	RAP215CC	RAP215CC-OH	211CC	RA-B3-5-1	RA2H3-2	
C23 Sundowner	LYC O-360-A	RAP215CC	RAP215CC-OH	211CC	RA-B3-5-1	RA2H3-2	
SN. M1285 - M1979 except M1971							
SN. M1971, M1980 - M2290 w/ Comf. Pk.	LYC O-360-A	RAP215CC	RAP215CC-OH	211CC	RA-B3-5-1	RA2H3-12	
SN. M197, M1980 - M2290 w/o Comf. Pk.	LYC O-360-A	RAP215CC	RAP215CC-OH	211CC	RA-B3-5-1	RA2H3-2	
SN. M2291 and up	LYC O-360-A	RAP215CC	RAP215CC-OH	211CC	RA-B3-5-1	RA2H3-12	
24 Sierra 200 SN. MA1 - MA363	LYC IO-360-A	RAP215CC	RAP215CC-OH	211CC	RA-B3-5-1		
A24 SN. MA364 - MA368	LYC IO-360-A	RAP215CC	RAP215CC-OH	211CC	RA-B3-5-1	RA2H3-2	
A24R SN. MC2 - MC150	LYC IO-360-A	RAP215CC	RAP215CC-OH	211CC	RA-B3-5-1	RA2H3-2	
B24R SN. MC151 - MC274	LYC IO-360-A	RAP215CC	RAP215CC-OH	211CC	RA-B3-5-1	RA2H3-2	
SN. MC275 - MC451 except MC449	LYC IO-360-A	RAP215CC	RAP215CC-OH	211CC	RA-B3-5-1	RA2H3-12	
C24R SN. MC449	LYC IO-360-A	RAP215CC	RAP215CC-OH	211CC	RA-B3-5-1	RA2H3-12	
SN. MC452 - MC536 except MC533	LYC IO-360-A	RAP215CC	RAP215CC-OH	211CC	RA-B3-5-1	RA2H3-12	
SN. MC533, MC537 - MC739 w/ Comf. Pk.	LYC IO-360-A	RAP215CC	RAP215CC-OH	211CC	RA-B3-5-1	RA2H3-12	
SN. MC533, MC537 - MC739 w/o Comf. Pk.	LYC IO-360-A	RAP215CC	RAP215CC-OH	211CC	RA-B3-5-1	RA2H3-2	
SN. MC740 and up	LYC IO-360-A	RAP215CC	RAP215CC-OH	211CC	RA-B3-5-1	RA2H3-12	
<b>Debonair</b>							
35-33, 35-A33 w/ Conversion Kit	TCM IO-470-J	RAP216CW	RAP216CW-OH	212CW			
35-B33 w/ Conversion Kit	TCM IO-470-K	RAP216CW	RAP216CW-OH	212CW			
35-C33 SN. CD826 - CD1118 and SN. CE1 - CE179 except CD982 w/ Conv.	TCM IO-470-K	RAP216CW	RAP216CW-OH	212CW		RA2H3-2	
35-C33A SN. CD826 - CD1118 and SN. CE1 - CE179 except CD982 w/ Conversion Kit	TCM IO-520-B, -BA	RAP216CW RAP242CW	RAP216CW-OH RAP242CW-OH	212CW		RA2H3-2	

All Airborne pumps available FAA Approved overhauled. For installation eligibility refer to FAA-PMA Supplement.  
For reference only.



Aircraft Manufacturer Model / Serial Number / Option	Engine Manufacturer & Model	Dry Air Pump			Filters	Regulator	Check Valve
		New RAPCO	Overhauled RAPCO	Overhauled OEM			
<b>E33 Bonanza</b> SN. CD1119 - CD1234, CE180 - CE289	TCM IO-470-K, IO-550	RAP216CW	RAP216CW-OH	212CW	RA-B3-5-1		
<b>E33A</b> SN. CD1119 - CD1234, CE180 - CE289	TCM IO-520-B	RAP216CW RAP242CW	RAP216CW-OH RAP242CW-OH	212CW			
<b>E33C</b>	TCM IO-520-B, -BA, -BB	RAP216CW RAP242CW	RAP216CW-OH RAP242CW-OH	212CW			
<b>F33 SN. CD1244 - 1254</b>	TCM IO-470-K, IO-550	RAP216CW	RAP216CW-OH	212CW	RA2J4-7, RA-D-9-14-5		
<b>F33A SN. CE290 - CE297</b>	TCM IO-520-B, -BA, -BB, IO-550	RAP242CW RAP442CW	RAP242CW-OH RAP442CW-OH		RA-D-9-14-5		
SN. CE298 - CE631	TCM IO-520-B, -BA, -BB, IO-550	RAP242CW RAP442CW	RAP242CW-OH RAP442CW-OH		RA2J4-7, RA-D-9-14-5		
SN. CE632 - CE1439, CE1441 - CE1456	TCM IO-520-B, -BA, -BB, IO-550	RAP216CW RAP442CW	RAP216CW-OH RAP442CW-OH	212CW	RA2J4-7, RA-D-9-14-5		
SN. CE1441 - CE1456	TCM IO-520-B, -BA, -BB, IO-550	RAP216CW RAP442CW	RAP216CW-OH RAP442CW-OH	212CW	RA2J4-7, RA-D-9-14-5		
SN. CE1440, CE1457 and up	TCM IO-520-B, -BA, -BB, IO-550	RAP216CW	RAP216CW-OH	212CW	RA2J4-7, RA-D-9-14-5		
SN. CE1056 - CE1439, CE1441 - CE1456 w/ Standby System	TCM IO-520-B, -BA, -BB, IO-550	RAP216CW	RAP216CW-OH	212CW	RA2J4-7, RA-D-9-14-5		
SN. CE1440, CE1457 and up w/ Standby	TCM IO-520-B, -BA, -BB, IO-550	RAP216CW	RAP216CW-OH	212CW	RA2J4-7, RA-D-9-14-5		
<b>F33C SN. CJ26 - CJ128</b>	TCM IO-520-B, -BA, -BB, IO-550	RAP242CW RAP442CW	RAP242CW-OH RAP442CW-OH		RA2J4-7, RA-D-9-14-5		
SN. CJ129 - CJ179	TCM IO-520-B, -BA, -BB, IO-550	RAP216CW RAP442CW	RAP216CW-OH RAP442CW-OH	212CW	RA2J4-7, RA-D-9-14-5		
SN. CJ180 and up	TCM IO-520-B, -BA, -BB, IO-550	RAP216CW	RAP216CW-OH	212CW	RA2J4-7, RA-D-9-14-5		
SN. CJ156 - CJ179 w/ Standby System	TCM IO-520-B, -BA, -BB, IO-550	RAP216CW	RAP216CW-OH	212CW	RA2J4-7, RA-D-9-14-5		
SN. CJ180 and up w/ Standby System	TCM IO-520-B, -BA, -BB, IO-550	RAP216CW	RAP216CW-OH	212CW	RA2J4-7, RA-D-9-14-5		
<b>G33 SN. CD1255 - CD1304</b>	TCM IO-470-N, IO-550	RAP216CW	RAP216CW-OH	212CW	RA2J4-7, RA-D-9-14-5		
<b>35-33 Debonair - See above</b>							
<b>35, A35 Bonanza w/ Conversion Kit</b>	TCM E-185-1, IO-550	RAP216CW	RAP216CW-OH	212CW			
<b>B35, 35R Bonanza w/ Conversion Kit</b>	TCM E-185-8, IO-550	RAP216CW	RAP216CW-OH	212CW			
<b>C35, D35, E35, F35 Bonanza w/ Conv.</b>	TCM E-185-11, IO-550	RAP216CW	RAP216CW-OH	212CW			
<b>G35 Bonanza w/ Conversion Kit</b>	TCM E-225-8, IO-550	RAP216CW	RAP216CW-OH	212CW			
<b>H35 Bonanza w/ Conversion Kit</b>	TCM O-470-G, IO-550	RAP216CW	RAP216CW-OH	212CW			
<b>J35, K35, M35 Bonanza w/ Conv. Kit</b>	TCM IO-470-C, IO-550	RAP216CW	RAP216CW-OH	212CW			
<b>N35, P35 Bonanza w/ Conversion Kit</b>	TCM IO-470-N, IO-550	RAP216CW	RAP216CW-OH	212CW			
<b>S35 Bonanza w/ Conversion Kit</b>	TCM IO-520-B, -BA, IO-550	RAP216CW	RAP216CW-OH	212CW			
SN. D7310 - D7628	TCM IO-520-B, -BA, IO-550	RAP216CW	RAP216CW-OH	212CW	RA-B3-5-1	RA2H3-2	
SN. D7629 - D7749	TCM IO-520-B, -BA, IO-550	RAP216CW	RAP216CW-OH	212CW	RA-B3-5-1	RA2H3-12	
SN. D7750 - D7976	TCM IO-520-B, -BA, IO-550	RAP216CW	RAP216CW-OH	212CW			
<b>V35 Bonanza</b>	TCM IO-520-B, -BA, IO-550	RAP216CW	RAP216CW-OH	212CW			
<b>V35A SN. D7977 - D8598</b>	TCM IO-520-B, -BA, -BB, IO-550	RAP216CW	RAP216CW-OH	212CW	RA-B3-5-1	RA2H3-2	
SN. D8599 - D9068	TCM IO-520-B, -BA, -BB, IO-550	RAP216CW	RAP216CW-OH	212CW	RA-B3-5-1		
<b>V35A-TC SN. D7977 - D8598</b>	TCM TSIO-520	RAP216CW	RAP216CW-OH	212CW	RA-B3-5-1		
SN. D8599 - D9068	TCM TSIO-520	RAP216CW	RAP216CW-OH	212CW	RA-B3-5-1		
<b>V35B SN. D9069 - D9855</b>	TCM IO-520-B, -BA, -BB, IO-550	RAP242CW	RAP242CW-OH		RA-D-9-14-5		
SN. D9856 and up Option	TCM IO-520-B, -BA, -BB, IO-550	RAP216CW RAP442CW	RAP216CW-OH RAP442CW-OH	212CW	RA2J4-7, RA-D-9-14-5		
<b>V35B-TC SN. D9069 - D9855</b>	TCM TSIO-520	RAP216CW	RAP216CW-OH		RA2J4-7, RA-D-9-14-5		
SN. D9856 and up	TCM TSIO-520	RAP216CW	RAP216CW-OH	212CW	RA2J4-7, RA-D-9-14-5		
<b>36, A36 Bonanza</b>							
SN. E1 - E183	TCM IO-520-B, -BA, -BB, IO-550	RAP216CW RAP242CW	RAP216CW-OH RAP242CW-OH	212CW	RA-B3-5-1		
SN. E184	TCM IO-520-B, -BA, -BB, IO-550	RAP242CW RAP442CW	RAP242CW-OH RAP442CW-OH		RA2J4-7, RA-B3-5-1		
SN. E185 - E196	TCM IO-520-B, -BA, -BB, IO-550	RAP216CW RAP242CW	RAP216CW-OH RAP242CW-OH	212CW	RA-B3-5-1		
SN. E197, E203 - E451	TCM IO-520-B, -BA, -BB, IO-550	RAP242CW RAP442CW	RAP242CW-OH RAP442CW-OH		RA2J4-7, RA-B3-5-1		
SN. E452 - E813	TCM IO-520-B, -BA, -BB, IO-550	RAP242CW RAP442CW	RAP242CW-OH RAP442CW-OH		RA2J4-7, RA-D-9-14-5		
SN. E814 - E2531 except E2524	TCM IO-520-B, -BA, -BB, IO-550	RAP216CW	RAP216CW-OH	212CW	RA2J4-7, RA-D-9-14-5		
SN. E2524, E2532 and up	TCM IO-520-B, -BA, -BB, IO-550	RAP216CW	RAP216CW-OH	212CW	RA2J4-7, RA-D-9-14-5		
SN. E2180 and up Standby System	TCM IO-520-B, -BA, -BB, IO-550	RAP216CW	RAP216CW-OH	212CW	RA2J4-7, RA-D-9-14-5		
<b>A36TC, B36TC, Bonanza</b> SN. EA442 - EA502 and EA504 Standby	TCM TSIO-520-U, -UB, IO-550	RAP216CW	RAP216CW-OH	212CW	RA2J4-7, RA-D-9-14-5		
SN. EA503, EA505 and up W/ Stbdy Sys.	TCM TSIO-520-U, -UB, IO-550	RAP216CW	RAP216CW-OH	212CW	RA2J4-7, RA-D-9-14-5		
<b>45 (YT-34) Mentor</b>	TCM E-225-8	RAP216CW	RAP216CW-OH	212CW			
<b>A45 (T-34A)</b>	TCM O-470	RAP216CW	RAP216CW-OH	212CW			
<b>B-45, D45 (T-34B)</b>	TCM O-470	RAP216CW	RAP216CW-OH	212CW			
<b>50, B50 Twin Bonanza</b>	LYC GO-435-C	RAP216CW	RAP216CW-OH	212CW			
<b>G50, H50 Twin Bonanza</b>	LYC IGSO-480-A	RAP442CW	RAP442CW-OH				
<b>55, 56, 58 Baron - See Below</b>							
<b>65-B80 Queen Air Non Deice</b> SN. LD362 and up	LYC IGSO-540-A	RAP441CC-9	RAP441CC-9-OH		RA2J4-6, RA-D-9-14-5		
<b>A65 Queen Air Non Deice</b> SN. LC240 - LC270	LYC IGSO-480-A	RAP442CW	RAP442CW-OH		RA-B3-5-1		
SN. LC271 and up	LYC IGSO-480-A	RAP442CW	RAP442CW-OH		RA2J4-7, RA-D-9-14-5		
<b>A65 Queen Air Deice</b> SN. LC271 and up	LYC IGSO-480-A	RAP442CW	RAP442CW-OH		RA2J4-7, RA-D-9-14-5		
<b>70 Queen Air</b>	LYC IGSO-480-A	RAP442CW	RAP442CW-OH		RA2J4-6, RA-D-9-14-5		
<b>95, B95 Travel Air</b>	LYC O-360-A	RAP215CC	RAP215CC-OH	211CC			
<b>B95A Travel Air</b>	LYC IO-360-B	RAP215CC	RAP215CC-OH	211CC			
<b>D95A Travel Air SN. TD534 - TD622</b>	LYC IO-360-B					RA2H3-2	
SN. TD623 - TD707	LYC IO-360-B					RA2H3-6	
<b>E95 Travel Air Non Deice SN. TD708 up</b>	LYC IO-360-B	RAP215CC	RAP215CC-OH	211CC			
<b>E95 Travel Air Deice SN. TD708 and up</b>	LYC IO-360-B	RAP441CC	RAP441CC-OH				
<b>95-55 Baron</b>	TCM IO-470-L	RAP216CW RAP442CW	RAP216CW-OH RAP442CW-OH	212CW			
<b>95-A55 Baron</b>	TCM IO-470-L	RAP216CW RAP442CW	RAP216CW-OH RAP442CW-OH	212CW			



**PNEUMATICS APPLICATIONS**

Aircraft Manufacturer Model / Serial Number / Option	Engine Manufacturer & Model	Dry Air Pump			Filters	Regulator	Check Valve
		New RAPCO	Overhauled RAPCO	Overhauled OEM			
95-B55 Baron Non Deice SN. TC1608 - TC2002 SN. TC2003 - TC2075	TCM IO-470-L	RAP442CW-14	RAP442CW-14-OH			RA2H3-6	
SN. Continues next page SN. TC2076 and up	TCM IO-470-L	RAP216CW RAP442CW-14	RAP216CW-OH RAP442CW-14-OH	212CW	RA2J4-7, RA-D-9-14-5		
95-B55 Baron Deice SN. TC2003 and up 95-C55	TCM IO-470-L TCM IO-520-C	RAP442CW-14 RAP242CW RAP442CW-12	RAP442CW-14-OH RAP242CW-OH RAP442CW-12-OH		RA2J4-7, RA-B3-5-1 RA-B3-5-1		
95-C55A	TCM IO-520-C	RAP242CW RAP442CW-12	RAP242CW-OH RAP442CW-12-OH				
D55 Non Deice SN. TE452 - TE767	TCM IO-520-C, -CB	RAP242CW RAP442CW-12	RAP242CW-OH RAP442CW-12-OH		RA2J4-7, RA-B3-5-1		
D55 Deice SN. TE452 - TE767 D55A Non Deice	TCM IO-520-C, -CB TCM IO-520-C, -CB	RAP442CW-12 RAP216CW RAP242CW	RAP442CW-12-OH RAP216CW-OH RAP242CW-OH	212CW	RA2J4-7, RA-D-9-14-5		
D55A Deice E55 Non Deice SN. TE768 - TE936	TCM IO-520-C, -CB TCM IO-520-C, -CB	RAP442CW-12 RAP242CW RAP442CW-12	RAP442CW-12-OH RAP242CW-OH RAP442CW-12-OH		RA2J4-7, RA-B3-5-1		
SN. TE937, TE939 - TE942	TCM IO-520-C, -CB	RAP242CW RAP442CW-12	RAP242CW-OH RAP442CW-12-OH		RA2J4-7, RA-D-9-14-5		
SN. TE938, TE943 - TE1113 SN. TE1114 and up	TCM IO-520-C, -CB TCM IO-520-C, -CB	RAP242CW RAP442CW-12	RAP242CW-OH RAP442CW-12-OH		RA2J4-7, RA-D-9-14-5		
E55 Deice SN. TE768 - TE942 except TE938	TCM IO-520-C, -CB	RAP442CW-14 RAP442CW-12	RAP442CW-14-OH RAP442CW-12-OH		RA2J4-7, RA-D-9-14-5		
SN. TE938, TE943 - TE1074 SN. TE1075 and up	TCM IO-520-C, -CB TCM IO-520-C, -CB	RAP442CW-14 RAP442CW-14	RAP442CW-14-OH RAP442CW-14-OH		RA2J4-7, RA-D-9-14-5		
55A Non Deice	TCM IO-520-C, -CB	RAP216CW RAP242CW	RAP216CW-OH RAP242CW-OH	212CW			
55A Deice 567C Baron Non Deice SN. TG1 - TG51	TCM IO-520-C, -CB LYC TIO-541-E	RAP442CW-12 RAP242CW	RAP442CW-12-OH RAP242CW-OH		RA-B3-5-1	RA2H3-6	
SN. TG52 - TG74 SN. TG75 - TG83 SN. TG84 - TG94	LYC TIO-541-E LYC TIO-541-E LYC TIO-541-E	RAP242CW RAP242CW RAP442CW	RAP242CW-OH RAP242CW-OH RAP442CW-OH		RA2J4-6, RA-B3-5-1 RA2J4-6, RA-B3-5-1 RA2J4-6, RA-B3-5-1		
567C Baron Deice SN. TG52 - TG74 58 Baron Non Deice SN. TH1 - TH177	LYC TIO-541-E TCM IO-520-C	RAP442CW RAP242CW	RAP442CW-OH RAP242CW-OH		RA2J4-6, RA-B3-5-1 RA2J4-7, RA-D-9-14-5		
SN. TH178 - TH186 SN. TH187 - TH873	TCM IO-520-C TCM IO-520-C	RAP242CW RAP242CW	RAP242CW-OH RAP242CW-OH		RA2J4-7, RA-D-9-14-5 RA2J4-7, RA-D-9-14-5		
SN. TH874 and up 58 Baron Deice SN. TH1 - TH177	TCM IO-520-C TCM IO-520-C	RAP216CW RAP442CW-14 RAP442CW-12	RAP216CW-OH RAP442CW-14-OH RAP442CW-12-OH	212CW	RA2J4-7, RA-D-9-14-5		
SN. TH178 - TH186	TCM IO-520-C TCM IO-520-C	RAP442CW-14 RAP442CW-12	RAP442CW-14-OH RAP442CW-12-OH		RA2J4-7, RA-D-9-14-5 RA2J4-7, RA-D-9-14-5		
SN. TH187 - TH851 except TH792	TCM IO-520-C TCM IO-520-C	RAP442CW-14 RAP442CW-12	RAP442CW-14-OH RAP442CW-12-OH		RA2J4-7, RA-D-9-14-5 RA2J4-7, RA-D-9-14-5		
SN. TH792, TH852 and up	TCM IO-520-C TCM IO-520-C	RAP442CW-14 RAP442CW-12	RAP442CW-14-OH RAP442CW-12-OH		RA2J4-7, RA-D-9-14-5 RA2J4-7, RA-D-9-14-5		
58P Baron Non Deice SN. TJ3 - TJ4 SN. TJ5 - TJ84	TCM TSIO-520-L, -LB TCM TSIO-520-L, -LB	RAP242CW-4 RAP242CW-4	RAP242CW-4-OH RAP242CW-4-OH		RA2J4-7 RA2J4-7		
SN. J85 - TJ97 except TJ86 SN. TJ86, TJ98 - TJ122 SN. TJ123 - TJ543 except TJ436	TCM TSIO-520-L, -LB TCM TSIO-520-L, -LB TCM TSIO-520-L, -LB	RAP242CW-4 RAP242CW-4 RAP242CW-4	RAP242CW-4-OH RAP242CW-4-OH RAP242CW-4-OH		RA2J4-7 RA2J4-7 RA2J4-7		
SN. TJ436, TJ444 and up 58P Baron Deice SN. TJ3 - TJ4 SN. TJ5 - TJ84	TCM TSIO-520-L, -LB TCM TSIO-520-L, -LB	RAP442CW-4 RAP442CW-4	RAP442CW-4-OH RAP442CW-4-OH		RA2J4-7 RA2J4-7		
SN. TJ85 - TJ97 except TJ86 SN. TJ86, TJ316 SN. TJ317 - TJ443 except TJ436	TCM TSIO-520-L, -LB TCM TSIO-520-L, -LB TCM TSIO-520-L, -LB	RAP442CW-4 RAP442CW-4 RAP442CW-4	RAP442CW-4-OH RAP442CW-4-OH RAP442CW-4-OH		RA2J4-7 RA2J4-7 RA2J4-7		
SN. TJ436, TJ444 and up 58TC Baron Non Deice SN. TK1 - TK56 SN. TK57 - TK150 except TK147	TCM TSIO-520-L, -LB TCM TSIO-520-L, -LB	RAP442CW-4 RAP242CW-4	RAP442CW-4-OH RAP242CW-4-OH		RA2J4-7, RA-D-9-14-5 RA2J4-7, RA-D-9-14-5		
SN. TK57 - TK150 except TK147 58TC Baron Deice SN. TK1 - TK56 SN. TK57 - TK150 except TK147	TCM TSIO-520-L, -LB TCM TSIO-520-L, -LB	RAP442CW-4 RAP442CW-4	RAP442CW-4-OH RAP442CW-4-OH		RA2J4-7, RA-D-9-14-5 RA2J4-7, RA-D-9-14-5		
60, A60 Duke Non Deice w/o Auto Pilot SN. P4 - P69 SN. P70 - P246	LYC TIO-541-E LYC TIO-541-E	RAP242CW RAP242CW	RAP242CW-OH RAP242CW-OH		RA-B3-5-1 RA-B3-5-1		
60, A60 Duke Non Deice w/ Auto Pilot SN. P4 - P69 SN. P70 - P246	LYC TIO-541-E LYC TIO-541-E	RAP242CW RAP242CW	RAP242CW-OH RAP242CW-OH		RA-B3-5-1 RA-B3-5-1		
A60 Duke Deice SN. P4 - P69 SN. P70 - P246	LYC TIO-541-E LYC TIO-541-E	RAP442CW RAP442CW	RAP442CW-OH RAP442CW-OH		RA-B3-5-1 RA-B3-5-1		
B60 Duke Non Deice SN. P247 - P508 Single Instrument SN. P247 - P508 Dual Instrument SN. P509 and up Single Instrument	LYC TIO-541-E LYC TIO-541-E LYC TIO-541-E	RAP242CW RAP442CW RAP242CW	RAP242CW-OH RAP442CW-OH RAP242CW-OH		RA2J4-7, RA-D-9-14-5 RA2J4-7, RA-D-9-14-5 RA2J4-7, RA-D-9-14-5		
SN. P509 and up Dual Instrument B60 Duke Deice SN. P247 - P307 Single Instrument SN. P308 - P378 Dual Instrument SN. P379 - P508	LYC TIO-541-E LYC TIO-541-E LYC TIO-541-E	RAP442CW RAP442CW RAP442CW	RAP442CW-OH RAP442CW-OH RAP442CW-OH		RA2J4-7, RA-D-9-14-5 RA2J4-7, RA-D-9-14-5 RA2J4-7, RA-D-9-14-5		
SN. P509 and up A65 Queen Air SN. 271 and up 65-B80 Queen Air 70 Queen Air 70 Duchess	LYC TIO-541-E LYC IGSO-480-A LYC IGSO-480-A LYC IGSO-480-A LYC O-360-A LYC LO-360-A	RAP442CW RAP442CW RAP442CW RAP442CW RAP215CC (Left) RAP216CW (Right)	RAP442CW-OH RAP442CW-OH RAP442CW-OH RAP442CW-OH RAP215CC-OH RAP216CW-OH	211CC 212CW	RA2J4-7, RA-D-9-14-5 RA2J4-7, RA-D-9-14-5 RA2J4-7, RA-D-9-14-5 RA2J4-7, RA-D-9-14-5 RA2J4-7, RA-D-9-14-5 RA2J4-7, RA-D-9-14-3		
SN. P509 and up A65 Queen Air SN. L318 - L317 B90 King Air SN. L318 - L317 B90 King Air SN. L318 - L317	LYC O-235-L2C PW PT-6 PW PT-6	RAP215CC RAP215CC	RAP215CC-OH RAP215CC-OH	211CC 212CW	RA-B3-5-1, RA2J4-4, -7 RA-B3-5-1		
77 Skipper 90 King Air SN. L318 - L317 A90 King Air SN. L318 - L317 B90 King Air SN. L318 - L317	LYC O-235-L2C PW PT-6 PW PT-6 PW PT-6	RAP215CC RAP215CC	RAP215CC-OH RAP215CC-OH	211CC 212CW	RA-B3-5-1, RA2J4-4, -7 RA-B3-5-1		
90 King Air SN. L318 - L317 A90 King Air SN. L318 - L317 B90 King Air SN. L318 - L317	PW PT-6 PW PT-6 PW PT-6				RA-B3-5-1 RA2H3-11		

All Airborne pumps available FAA Approved overhauled. For installation eligibility refer to FAA-PMA Supplement.  
For reference only.



## REPLACEMENT AIRCRAFT PARTS CO.

## PNEUMATICS APPLICATIONS

Aircraft Manufacturer Model / Serial Number / Option	Engine Manufacturer & Model	Dry Air Pump			Filters	Regulator	Check Valve
		New RAPCO	Overhauled RAPCO	Overhauled OEM			
<b>C90A, C90DT, C90GT1, Rudder Boost Filter</b> - also see section 4:					RA101-524009-0163		
C90 King Air SN. LJ502 and up	PW PT-6				RA-B3-5-1	RA2H3-11, -15	
C90A King Air SN. LJ1063 and up	PW PT-6				RA-B3-5-1	RA2H3-11, -15	
C90GT King Air	PW PT-6					RA2H3-11, -15	
C90GT1 King Air	PW PT-6					RA2H3-15	
E90 King Air SN. LW1 and up	PW PT-6				RA-B3-5-1	RA2H3-11, -15	
F90 SN. LA2 - LA204 except LA186.	PW PT-6				RA-B3-5-1	RA2H3-11, -15	
SN. LA200 - LA202	PW PT-6				RA-B3-5-1	RA2H3-11, -15	
95 Series Travel Air - see above	PW PT-6						
100 King Air Deice B2 - B89 and B93	PW PT-6				RA-B3-5-1	RA2H3-11	
SN. B1, B90 - B234 except B93	PW PT-6				RA-B3-5-1	RA2H3-11, -15	
SN. B235 and up	PW PT-6				RA-B3-5-1	RA2H3-15	
SN. BE1 and up	PW PT-6				RA-B3-5-1	RA2H3-15	
<b>A100-1 Rudder Boost Filter</b> - also see section 4:					RA101-524009-0163		
B100 King Air	PW PT-6					RA2H3-15	
<b>200, 200C, 200CT, 200T, Rudder Boost Filter</b> - also see section 4:					RA101-524009-0163		
200, B200 Super King Air Deice	PW PT-6						
SN. BB-2 thru BB-1265	PW PT-6				RA-B3-5-1	RA2H3-11, -15	
200C, B200C Super King Air Deice	PW PT-6						
SN. BL-1 thru BL-72	PW PT-6				RA-B3-5-1	RA2H3-11, -15	
200CT, B200CT Super King Air Deice	PW PT-6						
SN. BL-1 thru BL-4	PW PT-6				RA-B3-5-1	RA2H3-11, -15	
200T, B200T Super King Air Deice	PW PT-6						
SN. BL-1 thru BL-30 except BT-28	PW PT-6				RA-B3-5-1	RA2H3-11, -15	
<b>A200, A200C, A200CT, Rudder Boost Filter</b> - also see section 4:					RA101-524009-0163		
<b>B200, B200C, B200CT, B200T, B200GT, B200CTG, Rudder Boost Filter</b> - also see section 4:					RA101-524009-0163		
B200GT	PW PT-6					RA2H3-15	
300, 300LW, B300, B300C	PW PT-6					RA2H3-15	
1900, 1900C, 1900D	PW PT-6					RA2H3-15	
<b>Bellanca</b> - also see American Champion							
14-19	LYC O-435-A	RAP215CC	RAP215CC-OH	211CC	RA-B3-5-1		
14-19-2	TCM O-470-D	RAP216CW	RAP216CW-OH	212CW			
14-19-3	TCM O-470-F	RAP216CW	RAP216CW-OH	212CW	RA-B3-5-1		
14-19-3A	TCM O-470-F	RAP216CW	RAP216CW-OH	212CW	RA-B3-5-1	RA2H3-2	
17-30 Viking	TCM IO-520-D	RAP216CW	RAP216CW-OH	212CW	RA-B3-5-1	RA2H3-2	
17-30A Super Viking	TCM IO-520-K	RAP216CW	RAP216CW-OH	212CW	RA-B3-5-1	RA2H3-12	
17-31, 17-31TC	LYC IO-540-G	RAP215CC RAP441CC-7	RAP215CC-OH RAP441CC-7-OH	212CW	RA-B3-5-1	RA2H3-12	
17-31A, 17-31 ATC	LYC IO-540-G	RAP215CC RAP441CC-7	RAP215CC-OH RAP441CC-7-OH	211CC	RA-B3-5-1	RA2H3-12	
17-31A, 17-31 ATC, cont.		RAP215CC	RAP215CC-OH	211CC	RA-B3-5-1	RA2H3-12	
<b>Britten Norman / Pilatus Britten Norman</b>							
BN-2A Islander	LYC O-540-E, IO-540-K	RAP215CW	RAP215CC-OH	211CC	RA-D9-18-1, RA1J7-1	RA2H3-2	RA1H5-1
Deice	LYC O-540-E, IO-540-K	RAP442CW	RAP442CW-OH		RA-D9-18-1, RA1J7-1		
BN2A MK, III, III-2, BKN2A MK, III-3						RA2H3-2	
<b>Cessna</b>							
120, 140 with Lycoming	LYC O-235	RAP215CC	RAP215CC-OH	211CC			
150, 150A, B, C w/ Conversion Kit	TCM O-200-A	RAP215CC-9	RAP215CC-9-OH	211CC-9	RA-B3-5-1		
150 SN. 15060088 - 15060772	TCM O-200-A	RAP215CC-9	RAP215CC-9-OH	211CC-9	RA-B3-5-1	RA2H3-2	
SN. 15069309 - 15078505	TCM O-200-A	RAP215CC-9	RAP215CC-9-OH	211CC-9	RA-B3-5-1, RA-D-9-14-5	RA2H3-12	
A150K Aerobat A1500001 - A1500022E	TCM O-200-A	RAP215CC-9	RAP215CC-9-OH	211CC-9	RA-B3-5-1, RA-D-9-14-5	RA2H3-12	
SN. A1500227 - A1500480	TCM O-200-A	RAP215CC-9	RAP215CC-9-OH	211CC-9	RA-B3-5-1, RA-D-9-14-5	RA2H3-12	
A150L A1500227 - A150048C	TCM O-200-A	RAP215CC-9	RAP215CC-9-OH	211CC-9	RA-B3-5-1, RA-D-9-14-5	RA2H3-12	
SN. A1500481 - A1500523	TCM O-200-A	RAP215CC-9	RAP215CC-9-OH	211CC-9	RA-B3-5-1	RA2H3-12	
A150M SN. A1500524 - A150068E	TCM O-200-A	RAP215CC-9	RAP215CC-9-OH	211CC-9	RA-B3-5-1	RA2H3-12	
F150K, Reims F15000530 - F1500065E	TCM O-200-A	RAP215CC-9	RAP215CC-9-OH	211CC-9	RA-B3-5-1, RA-D-9-14-5	RA2H3-12	
F150L SN. F15000659 - F15001143	TCM O-200-A	RAP215CC-9	RAP215CC-9-OH	211CC-9	RA-B3-5-1, RA-D-9-14-5	RA2H3-12	
F150M SN. F15001144 - F1500118E	TCM O-200-A	RAP215CC-9	RAP215CC-9-OH	211CC-9	RA-B3-5-1, RA-D-9-14-5	RA2H3-12	
SN. F15001190 - F15001339	TCM O-200-A	RAP215CC-9	RAP215CC-9-OH	211CC-9	RA-B3-5-1	RA2H3-12	
FA150K SN. FA1500001 - FA1500081	TCM O-200-A	RAP215CC-9	RAP215CC-9-OH	211CC-9	RA-B3-5-1, RA-D-9-14-5	RA2H3-12	
FA150L SN. FA1500082 - FA1500261	TCM O-200-A	RAP215CC-9	RAP215CC-9-OH	211CC-9	RA-B3-5-1, RA-D-9-14-5	RA2H3-12	
FA150M SN. FA1500262 - FA1500271	TCM O-200-A	RAP215CC-9	RAP215CC-9-OH	211CC-9	RA-B3-5-1, RA-D-9-14-5	RA2H3-12	
SN. FA1500272 - FA1500312	TCM O-200-A	RAP215CC-9	RAP215CC-9-OH	211CC-9	RA-B3-5-1	RA2H3-12	
152 SN. 15279404 and up	LYC O-235	RAP215CC	RAP215CC-OH	211CC	RA-B3-5-1, RA-D-9-18-1	RA2H3-12	
152 w/ Elec. Stdb. SN. 15285940 and up	LYC O-235	RAP215CC (Primary) RAP216CW (Standby)	RAP215CC-OH RAP216CW-OH	211CC 212CW	RA-B3-5-1, RA-D-9-18-1 212CW	RA2H3-12 RA2H3-12	
A152 Aerobat SN. A1520735 and up	LYC O-235	RAP215CC	RAP215CC-OH	211CC	RA-B3-5-1, RA-D9-18-1	RA2H3-12	
A152 w/ Elec. Stdb. SN. A1521028 & up	LYC O-235	RAP215CC (Primary) RAP216CW (Standby)	RAP215CC-OH RAP216CW-OH	211CC 212CW	RA-B3-5-1, RA-D-9-18-1	RA2H3-12 RA2H3-23	
F152 Reims F150201429 - F1520180E	LYC O-235	RAP215CC	RAP215CC-OH	211CC	RA-B3-5-1, RA-D9-18-1	RA2H3-12	
FA152 SN. FA1520337 and up	LYC O-235	RAP215CC	RAP215CC-OH	211CC	RA-B3-5-1, RA-D9-18-1	RA2H3-12	
170B w/ Pully Pump Mod. 25373 and up	TCM O-300-A			212CW-6 (CPO)			
172 with Pully Driven Pump Mod.	TCM O-300-A, -B			212CW-6 (CPO)	RA-B3-5-1	RA2H3-2	
172A thru H with Pully Driven Vac Pump	TCM O-300-C			212CW-6 (CPO)			
172A	TCM O-300-D	RAP215CC	RAP215CC-OH	211CC			
172B, C Skyhawk	TCM O-300-D	RAP215CC	RAP215CC-OH	211CC			
172D, E	TCM O-300-D	RAP215CC	RAP215CC-OH	211CC			
172F, G, H SN. 17251823 - 17256512	TCM O-300-D	RAP215CC	RAP215CC-OH	211CC			
172I thru P SN. 17256513 - 17257164	LYC O-320-E	RAP215CC	RAP215CC-OH	211CC	RA-B3-5-1, RA-D-9-14-5		
SN. 17257165 - 17259760	LYC O-320-E	RAP215CC-9	RAP215CC-9-OH	211CC-9	RA-B3-5-1, RA-D-9-14-5	RA2H3-12	
SN. 17259761 - 17262866	LYC O-320-E, H	RAP215CC	RAP215CC-OH	211CC	RA-B3-5-1, RA-D-9-14-5	RA2H3-12	
SN. 17262867 - 17265684	LYC O-320-E, H	RAP215CC	RAP215CC-OH	211CC	RA-B3-5-1, RA1J10-1	RA2H3-12	
SN. 17265685 - 17276654 and up.	LYC O-320-E, H	RAP215CC	RAP215CC-OH	211CC	RA-B3-5-1, RA-D9-18-1	RA2H3-12	
172Q Outlass	LYC O-360-A	RAP215CC (Upper) RAP216CW (Lower)	RAP215CC-OH RAP216CW-OH	211CC 212CW		RA2H3-12	
SN. 17276260 & w/ Elec. Standby							
172R, S Skyhawk SN. 17280001 and up	LYC IO-360-L	RAP215CC (Upper) RAP216CW (Lower)	RAP215CC-OH RAP216CW-OH	211CC 212CW	RA-D9-18-1	RA2H3-48	
172RG Outlass	LYC O-360-F	RAP215CC	RAP215CC-OH	211CC		RA2H3-12	

All Airborne pumps available FAA Approved overhauled. For installation eligibility refer to FAA-PMA Supplement. For reference only.

**REPLACEMENT AIRCRAFT PARTS CO.**
**PNEUMATICS APPLICATIONS**

Aircraft Manufacturer Model / Serial Number / Option	Engine Manufacturer & Model	Dry Air Pump			Filters	Regulator	Check Valve
		New RAPCO	Overhauled RAPCO	Overhauled OEM			
<b>F172</b> Reims SN. F172-0019 - F172-0085	RR, TCM O-300-D				RA-B3-5-1	RA2H3-2	
SN. F172-0086 - F17200804	RR, TCM O-300-D				RA-D-9-14-5		
SN. F17200805 - F17201234	TCM O-300-D	RAP215CC-9	RAP215CC-9-OH	211CC-9	RA-B3-5-1, RA-D-9-14-5		
SN. F17201235 - F17201384	LYC O-320-E	RAP215CC	RAP215CC-OH	211CC	RA-B3-5-1		
SN. F17201385 and up	LYC O-320-E	RAP215CC	RAP215CC-OH	211CC	RA-B3-5-1, RA-D-9-14-5		
<b>F172 w/ Elec. Standby</b> F17202234 & up	LYC O-320-D	RAP215CC (Upper) RAP216CW (Lower)	RAP215CC-OH RAP216CW-OH	211CC 212CW	RA-B3-5-1		
<b>FR172K</b> SN. FR17200591 - FR17200675	TCM, RR O-300-K, -KB	RAP215CC	RAP215CC-OH	211CC	RA-B3-5-1	RA2H3-12	
<b>P172D</b> SN. P17257120 - P17257188	TCM GO-300-E	RAP216CW	RAP216CW-OH	212CW		RA2H3-2	
<b>R172E, R172F Hawk XP</b>	TCM IO-360-D	RAP215CC	RAP215CC-OH	211CC			
<b>R172H Hawk XP</b>	TCM IO-360-C, -D, -H	RAP215CC	RAP215CC-OH	211CC			
<b>R172J Hawk XP</b>	TCM IO-360-H, -HB	RAP215CC	RAP215CC-OH	211CC			
<b>R172K</b> SN. R1722000 - R1723454	TCM IO-360-K, -KB	RAP215CC	RAP215CC-OH	211CC	RA-B3-5-1	RA2H3-12	
<b>175, 175A, 175B, 175C Skylark</b> w/ Conv.	TCM GO-300-A, -C, -D, -E	RAP216CW	RAP216CW-OH	212CW			
<b>177 Cardinal</b> SN. 17700001 - 17701164	LYC O-320-E	RAP215CC	RAP215CC-OH	211CC	RA-B3-5-1, RA-D-9-14-5	RA2H3-12	
SN. 17701165 - 17701530	LYC O-360-A	RAP215CC-9	RAP215CC-9-OH	211CC-9	RA-B3-5-1, RA-D-9-14-5	RA2H3-12	
SN. 17701531 - 17702542	LYC O-360-A	RAP215CC	RAP215CC-OH	211CC	RA-B3-5-1, RA-D-9-14-5	RA2H3-12	
SN. 17702543 - 17702752	LYC O-360-A	RAP215CC	RAP215CC-OH	211CC	RA-B3-5-1, RA-D9-18-1	RA2H3-12	
<b>177RG</b> SN. 177RG001 - 177RG1012	LYC IO-360-A	RAP215CC	RAP215CC-OH	211CC	RA-B3-5-1, RA-D-9-14-5	RA2H3-12	
SN. 177RG1013 - 177RG1087	LYC IO-360-A	RAP215CC	RAP215CC-OH	211CC	RA-B3-5-1, RA-D9-18-1	RA2H3-12	
SN. 177RG1088	LYC IO-360-A	RAP215CC	RAP215CC-OH	211CC	RA-B3-5-1, RA-D9-14-5	RA2H3-12	
SN. 177RG1089 - 177RG1386	LYC IO-360-A	RAP215CC	RAP215CC-OH	211CC	RA-B3-5-1, RA-D9-18-1	RA2H3-12	
<b>F177RG</b> SN. F177RG001 - F177RG016C	LYC IO-360-A	RAP215CC	RAP215CC-OH	211CC	RA-B3-5-1, RA-D-9-14-5	RA2H3-12	
SN. F177RG0161 - F177RG0177	LYC IO-360-A	RAP215CC	RAP215CC-OH	211CC	RA-B3-5-1	RA2H3-12	
<b>180, 180A thru F Skywagon</b> w/ Conv.	TCM O-470-A, -K, -L, -R	RAP216CW	RAP216CW-OH	212CW	RA-B3-5-1, RA-D-9-14-5		
<b>180G</b>	TCM O-470-L, -R	RAP216CW	RAP216CW-OH	212CW	RA-B3-5-1	RA2H3-2	
<b>180</b> SN. 18051446 - 1805230C	TCM O-470-L, -R	RAP216CW	RAP216CW-OH	212CW	RA-D-9-14-5		
SN. 18052310 - 18052384	TCM O-470-L, -R, -S	RAP216CW	RAP216CW-OH	212CW	RA-B3-5-1, RA-D-9-14-5		
<b>182 thru G Skylane</b> w/ Conversion Kit	TCM O-470-L, -R	RAP216CW	RAP216CW-OH	212CW	RA-B3-5-1		
<b>182H thru M</b> SN. 18255845 - 1826044E	TCM O-470-R, -S	RAP216CW	RAP216CW-OH	212CW	RA-D-9-14-5		
<b>182N and P</b> SN. 18260446 - 1826246E	TCM O-470-R, -S	RAP216CW	RAP216CW-OH	212CW	RA-B3-5-1, RA-D-9-14-5	RA2H3-12	
SN. 8260466 - 18262778	TCM O-470-R, -S	RAP216CW	RAP216CW-OH	212CW	RA-D-9-14-5	RA2H3-12	
SN. 182662779 - 18265175	TCM O-470-R, -S	RAP216CW	RAP216CW-OH	212CW	RA1J10-1	RA2H3-12	
SN. 182665716 and up	TCM O-470-R, -S	RAP216CW	RAP216CW-OH	212CW	RA-D9-18-1	RA2H3-12	
w/ Elec. Driven Pump 18268435 and up	TCM O-470-R, -S	RAP216CW	RAP216CW-OH	212CW		RA2H3-12	
<b>182Q thru R Skylane</b>	TCM O-470-J	RAP216CW	RAP216CW-OH	212CW		RA2H3-12	
<b>182S, 182T, T182T</b> SN. 18280001 and up	LYC IO-540-A LYC IO-540-A	RAP215CC (Upper) RAP216CW (Lower)	RAP215CC-OH RAP216CW-OH	211CC 212CW		RA2H3-48	
<b>F182</b> Reims SN. F18200001 - F1820002E	TCM O-470-S	RAP216CW	RAP216CW-OH	212CW	RA1J10-1		
SN. F18200026 - F18200169	TCM O-470-U	RAP216CW	RAP216CW-OH	212CW	RA-D9-18-1		
<b>FR182</b> SN. F18200001 - F1820007C	LYC O-540-J	RAP215CC	RAP215CC-OH	211CC	RA-B3-5-1, RA-D9-18-1	RA2H3-12	
<b>R182, TR182</b> SN. R18200001 and up	LYC O-540-J	RAP215CC	RAP215CC-OH	211CC	RA-B3-5-1, RA-D9-18-1	RA2H3-12	
w/ Elec. Drive Pump R18202000 and up	LYC O-540-J	RAP216CW	RAP216CW-OH	212CW			
<b>T182</b> SN. 18267716 - 18268434	LYC O-540-L	RAP215CC	RAP215CC-OH	211CC	RA-D9-18-1	RA2H3-12	
SN. 18268435 and up, Elec. Driven Pump	LYC O-540-L	RAP216CW	RAP216CW-OH	212CW	RA-D9-18-1		
<b>185A, B, Skywagon</b> w/ Conversion Kit	TCM IO-470-F	RAP216CW	RAP216CW-OH	212CW			
<b>185C</b> SN. 185-0654 - 185-0776	TCM IO-470-F	RAP216CW	RAP216CW-OH	212CW	RA-B3-5-1	RA2H3-2	
<b>185D</b> SN. 185-0777 - 18502142	TCM IO-470-F	RAP216CW	RAP216CW-OH	212CW	RA-D-9-14-5		
<b>185</b> SN. 18502143 - 1850231C	TCM IO-520-D	RAP216CW	RAP216CW-OH	212CW	RA-B3-5-1, RA-D-9-14-5		
<b>A185E, F</b>	TCM IO-520-D	RAP216CW	RAP216CW-OH	212CW			
<b>188, 188A, 188B Ag Wagon</b>	TCM O-470-R, -S	RAP216CW	RAP216CW-OH	212CW			
<b>A188, A188A, A188B</b>	TCM IO-520-D	RAP216CW	RAP216CW-OH	212CW			
<b>205, 205A</b>	TCM IO-470-S	RAP216CW	RAP216CW-OH	212CW			
<b>206 Stationair / Super Skywagon</b>	TCM IO-520-A	RAP216CW	RAP216CW-OH	212CW			
<b>206, U206, U206A, P206, P206A thru E</b>							
SN. 20680001 and up	LYC IO-540-A	RAP215CC (Upper) RAP216CW (Lower)	RAP215CC-OH RAP216CW-OH	211CC 212CW	RA-D9-18-1	RA2H3-48	
<b>U206B thru G</b>	TCM IO-520-F	RAP216CW	RAP216CW-OH	212CW	RA-B3-5-1		
<b>U206, TU206 Stationair</b> Single Pump	TCM IO-520-FC, TSIO-520-C,M	RAP216CW	RAP216CW-OH	212CW	RA-B3-5-1, RA-D-9-14-5		
SN. U20602200 - U20603449							
SN. U20603450 and up	TCM IO-520-FC, TSIO-520-C,M	RAP216CW	RAP216CW-OH	212CW	RA-B3-5-1, RA-D9-18-1		
<b>U206, TU206</b> Dual Pump	TCM IO-520-A,F, TSIO-520-C,M	RAP442CW-8 (Right)	RAP442CW-8-OH		RA-B3-5-1		
SN. U20606700 and up							
<b>U206, TU206 w/ Electric Standby</b>	TCM IO-520-A,F, TSIO-520-C,M	RAP216CW	RAP216CW-OH	212CW	RA-B3-5-1		
<b>TU206A thru E, TP206A thru E</b>	TCM TSIO-520-C	RAP216CW	RAP216CW-OH	212CW			
<b>TU206F</b>	TCM TSIO-520-C	RAP242CW	RAP242CW-OH				
<b>207 T207 Skywagon</b>	TCM IO-520-F, TSIO-520-G,-M	RAP216CW	RAP216CW-OH	212CW	RA-D-9-14-5		
SN. 20700001 - 20700220							
SN. 20700221 - 20700355 & 20700365	TCM IO-520-F, TSIO-520-G,-M	RAP216CW	RAP216CW-OH	212CW	RA-B3-5-1, RA-D-9-14-5		
SN. 20700730 and up	TCM IO-520-F, TSIO-520-G,-M	RAP216CW	RAP216CW-OH	212CW	RA-B3-5-1, RA-D9-18-1		
<b>210 (Centurion)</b> Non Deice Single Pump w/ Conversion Kit	TCM IO-470-E, -S, IO-520-L	RAP216CW	RAP216CW-OH	212CW	RA-B3-5-1		
<b>210</b> Non Deice, Dual Pump w/ Conv. Kit	TCM IO-470-E, -S, IO-520-A, -L	RAP216CW	RAP216CW-OH	212CW	RA-B3-5-1		
With SK210-103 Mod. w/ Conversion Kit	TCM IO-470-E, -S, IO-520-A, -L	RAP216CW	RAP216CW-OH	212CW	RA-B3-5-1		
<b>210</b> Electric System w/ Conversion Kit	TCM IO-470-E, -S, IO-520-A, -L	RAP216CW	RAP216CW-OH	212CW	RA-B3-5-1		
<b>210</b> Deice, Single Pump w/ Conversion Kit	TCM IO-470-E, -S, IO-520-A, -L	RAP442CW-8	RAP442CW-8-OH		RA-B3-5-1		
<b>210</b> Deice, Dual Pump	TCM IO-520-A, -J, -L	RAP216CW (Left) RAP442CW-8 (Right)	RAP216CW-OH RAP442CW-8-OH	212CW	RA-B3-5-1		
SN. 21064136 - 21064535 w/ Mod.							
SN. 21064536 - 21064772	TCM IO-520-A, -J, -L	RAP216CW (Left) RAP442CW-8 (Right)	RAP216CW-OH RAP442CW-8-OH	212CW	RA-B3-5-1		
SN. 21064773 thru 21064897	TCM IO-520-A, -J, -L	RAP442CW-8	RAP442CW-8-OH		RA-B3-5-1		
SN. 21064898 - 21065009	TCM IO-520-L	RAP442CW-8	RAP442CW-8-OH		RA-B3-5-1		
<b>T210</b> Non Deice, Single Pump	TCM TSIO-520-C, -H, -R	RAP216CW	RAP216CW-OH	212CW	RA-B3-5-1		
SN. 21059810 and up							
<b>T210</b> Non Deice, Dual Pump	TCM TSIO-520-C, -H, -R	RAP216CW	RAP216CW-OH	212CW	RA-B3-5-1		
SN. 21064536 - 21064772							
SN. 21064136 - 21064535 w/ Mod.	TCM TSIO-520-C, -H, -R	RAP216CW (Left)	RAP216CW-OH	212CW	RA-B3-5-1		
<b>T210</b> with Electric Driven System	TCM TSIO-520-C, -H, -R	RAP216CW	RAP216CW-OH	212CW	RA-B3-5-1	RA2H3-2	
<b>T210</b> Deice, Single Pump	TCM TSIO-520-C, -H, -R	RAP442CW-8	RAP442CW-8-OH		RA-B3-5-1		

All Airborne pumps available FAA Approved overhauled. For installation eligibility refer to FAA-PMA Supplement.  
For reference only.



## REPLACEMENT AIRCRAFT PARTS CO.

## PNEUMATICS APPLICATIONS

Aircraft Manufacturer Model / Serial Number / Option	Engine Manufacturer & Model	Dry Air Pump			Filters	Regulator	Check Valve
		New RAPCO	Overhauled RAPCO	Overhauled OEM			
<b>T210</b> Deice, Dual Pump SN. 21064136 - 21064535 w/ Mod. SN. 21064536 - 21064772	TCM TSIO-520-C, -H, -R	RAP216CW (Left) RAP442CW-8 (Right)	RAP216CW-OH RAP442CW-8-OH	212CW	RA-B3-5-1		
SN. 21064773 - 21064897	TCM TSIO-520-C, -H, -R	RAP216CW (Left) RAP442CW-8 (Right)	RAP216CW-OH RAP442CW-8-OH	212CW	RA-B3-5-1		
SN. 21064898 and up	TCM TSIO-520-C, -H, -R	RAP216CW RAP442CW-8	RAP216CW-OH RAP442CW-8-OH	212CW	RA-B3-5-1	RA2H3-2	
<b>P210</b> Non Deice, Single Pump SN. P2100001 - P21000811 SN. P21000812 and up	TCM TSIO-520-P	RAP216CW	RAP216CW-OH	212CW	RA-B3-5-1		
<b>P210</b> Non Deice, Dual Pumps <b>P210</b> Electric Driven Pump SN. P21000835 and up SN. P21000001 - P21000760 w/ Mod.	TCM TSIO-520-P	RAP216CW RAP442CW-8	RAP216CW-OH RAP442CW-8-OH	212CW	RA-B3-5-1		
SN. P21000835 and up	TCM TSIO-520-P	RAP216CW	RAP216CW-OH	212CW	RA-B3-5-1		
<b>P210</b> Deice, Single Pump SN. P21000001 - P21000811 SN. P21000812 and up	TCM TSIO-520-P	RAP442CW-8	RAP442CW-8-OH		RA-B3-5-1		
<b>P210</b> Deice, Dual Pump SN. P210000761 - P21000834 SN. P21000835 and up SN. P21000001 - P21000760 w/ Mod.	TCM TSIO-520-P	RAP442CW-8 RAP216CW (Left) RAP442CW-8 (Right)	RAP442CW-8-OH RAP216CW-OH RAP442CW-8-OH	212CW	RA-B3-5-1, RA-D9-18-1		
<b>T303 Crusader</b> Non Deice	TCM TSIO-520-AE TCM LTSIO-520-AE	RAP216CW (Left) RAP215CC (Right)	RAP216CW-OH RAP215CC-OH	212CW 211CC	RA-B3-5-1, RA-D9-18-1	RA2H3-2	RA1H5-1
<b>T303</b> Deice	TCM TSIO-520-AE TCM LTSIO-520-AE	RAP442CW-8 (Left) RAP441CC-3 (Right)	RAP442CW-8-OH RAP441CC-3-OH		RA-B3-5-1, RA-D9-18-1		
<b>305A thru F Bird Dog</b> <b>310</b> <b>310A, 310B</b>	TCM O-470 TCM O-470-B, -M TCM O-470-B, -M	RAP216CW RAP216CW RAP216CW	RAP216CW-OH RAP216CW-OH RAP216CW-OH	212CW 212CW 212CW	RA-B3-5-1		
<b>310C thru H and J</b> Non Deice	TCM O-470-D, -U	RAP216CW RAP242CW	RAP216CW-OH RAP242CW-OH	212CW			
<b>310C thru H and J</b> Deice	TCM O-470-D, -U	RAP442CW	RAP442CW-OH				
<b>E310H, E310J</b> Non Deice	TCM IO-470-D, -U	RAP216CW RAP242CW	RAP216CW-OH RAP242CW-OH	212CW			
<b>E310H, E310J</b> Deice	TCM IO-470-D, -U	RAP442CW	RAP442CW-OH				
<b>310I, 310J</b> Non Deice w/ Conversion Kit	TCM IO-470-U	RAP216CW RAP242CW	RAP216CW-OH RAP242CW-OH	212CW			
<b>310I, 310J</b> Deice	TCM IO-470-U	RAP442CW	RAP442CW-OH				
<b>310K</b> Non Deice	TCM IO-470-V, -VO	RAP216CW RAP242CW	RAP216CW-OH RAP242CW-OH	212CW			
<b>310K</b> Deice	TCM IO-470-V, -VO	RAP442CW	RAP442CW-OH				
<b>310L</b> , without Auto Pilot w/ Conv. Kit	TCM IO-470-V, -VO				RA-B3-5-1, RA-D9-18-1		RA1H5-1
<b>310L</b> with Auto Pilot	TCM IO-470-V, -VO	RAP242CW	RAP242CW-OH		RA-B3-5-1, RA-D-9-14-5		RA1H5-1
<b>310N</b> , without Auto Pilot	TCM IO-470-V, -VO				RA-B3-5-1, RA-D-9-14-5		RA1H5-1
<b>310N</b> with Auto Pilot	TCM IO-470-V	RAP242CW	RAP242CW-OH		RA-B3-5-1, RA-D-9-14-5		RA1H5-1
<b>310P</b> , without Auto Pilot, w/ Conv. Kit with Auto Pilot	TCM IO-470-V TCM IO-470-V	RAP216CW RAP242CW	RAP216CW-OH RAP242CW-OH	212CW	RA-B3-5-1, RA-D-9-14-5		RA1H5-1
<b>T310P</b> w/ Conversion Kit	TCM TSIO-520-B, -BB	RAP242CW	RAP242CW-OH		RA-B3-5-1, RA-D-9-14-5		RA1H5-1
<b>T310P</b> Deice	TCM TSIO-520-B, -BB	RAP442CW	RAP442CW-OH				
<b>310Q</b> , without Auto Pilot, w/ Conv. Kit SN. 310Q0001 - 310Q0459 SN. 310Q0460 - 310Q0952	TCM TSIO-520-B, -BB TCM IO-470-V TCM IO-470-V				RA-B3-5-1, RA-D-9-14-5		RA1H5-1
SM. 310Q0953 and up	TCM IO-470-V	RAP216CW	RAP216CW-OH	212CW	RA-B3-5-1, RA-D-9-14-5	RA2H3-5	
<b>310Q with Auto Pilot</b> w/ Conversion Kit SN. 310Q0001 - 310Q0459 SN. 310Q0460 and up	TCM IO-470-V TCM IO-470-V TCM IO-470-V				RA-B3-5-1, RA-D-9-14-5		RA1H5-1
<b>T310Q</b> Non Deice, w/ Conversion Kit	TCM TSIO-520-B, -BB	RAP242CW	RAP242CW-OH		RA-B3-5-1	RA2H3-5	
<b>T310Q</b> Deice	TCM TSIO-520-B, -BB	RAP442CW	RAP442CW-OH				
<b>310R</b> Non Deice	TCM IO-520-M, -MB	RAP216CW	RAP216CW-OH	212CW	RA-B3-5-1, RA2J4-4	RA2H3-5	
<b>310R</b> Deice	TCM IO-520-M, -MB	RAP442CW	RAP442CW-OH		RA2J4-4		
<b>T310R</b> Non Deice, w/ Conversion Kit	TCM TSIO-520-B, -BB	RAP242CW	RAP242CW-OH		RA2J4-4		
<b>T310R</b> Deice	TCM TSIO-520-B, -BB	RAP442CW	RAP442CW-OH				
<b>320, -1, -A, -B Skynight</b> , w/o Auto Pilot with Auto Pilot, w/ Conversion Kit with Deice, w/ Conversion Kit	TCM TSIO-470-B, -C TCM TSIO-470-B, -C TCM TSIO-470-B, -C	RAP216CW RAP242CW RAP442CW	RAP216CW-OH RAP242CW-OH RAP442CW-OH	212CW			
<b>320</b> Skynight, without Auto Pilot, w/ Con. with Auto Pilot	TCM TSIO-470-D TCM TSIO-470-D	RAP216CW RAP242CW	RAP216CW-OH RAP242CW-OH	212CW			
<b>320</b> Deice	TCM TSIO-470-D	RAP442CW	RAP442CW-OH				
<b>320D thru F Skynight</b> w/ Conversion Kit Deice w/ Conversion Kit	TCM TSIO-520-B, -BB TCM TSIO-520-B, -BB	RAP242CW RAP442CW	RAP242CW-OH RAP442CW-OH				
<b>321</b>	TCM O-470-2	RAP216CW	RAP216CW-OH	212CW			
<b>335</b> Non Deice	TCM TSIO-520-EB	RAP216CW	RAP216CW-OH	212CW	RA-B3-5-1		
<b>335</b> Deice	TCM TSIO-520-EB	RAP442CW	RAP442CW-OH		RA-B3-5-1		
<b>336 Skymaster</b>	TCM IO-360-A	RAP215CC	RAP215CC-OH	211CC	RA-B3-5-1		
<b>337 Skymaster</b> , Non Deice SN. 3370001 - 3370755 SN. 3370756 - 3370963 SN. 3370964 - 3371193 SN. 3371194 - 33701462 SN. 33701463 - 33701550 SN. 33701551 - 33701610 SN. 33701611	TCM IO-360-C, -D, -DB TCM IO-360-C, -D, -DB TCM IO-360-C, -D, -DB TCM IO-360-C, -D, -DB TCM IO-360-C, -D, -DB TCM IO-360-C, -D, -DB TCM IO-360-C, -D, -DB	RAP215CC RAP215CC RAP215CC-9 RAP215CC RAP215CC RAP215CC	RAP215CC-OH RAP215CC-OH RAP215CC-9-OH RAP215CC-OH RAP215CC-OH RAP215CC-OH	211CC 211CC-9 211CC 211CC 211CC	RA-B3-5-1, RA-D-9-14-5 RA-B3-5-1, RA-D-9-14-5 RA-B3-5-1, RA-D-9-14-5 RA-B3-5-1, RA-D-9-14-5 RA-B3-5-1, RA-D-9-14-5 RA-B3-5-1, RA1J10-1 RA-B3-5-1, RA1J10-1		
<b>337</b> Deice SN. 33701490 and up	TCM IO-360-C, -D, -DB	RAP441CC	RAP441CC-OH		RA-B3-5-1		

All Airborne pumps available FAA Approved overhauled. For installation eligibility refer to FAA-PMA Supplement. For reference only.



**PNEUMATICS APPLICATIONS**

Aircraft Manufacturer Model / Serial Number / Option	Engine Manufacturer & Model	Dry Air Pump			Filters	Regulator	Check Valve
		New RAPCO	Overhauled RAPCO	Overhauled OEM			
F337 Non Deice SN. F33700001 - F33700055	TCM IO-360-GB	RAP215CC	RAP215CC-OH	211CC	RA-D-9-14-5		
SN. F33700056 - F33700063	TCM IO-360-GB	RAP215CC	RAP215CC-OH	211CC	RA-D-9-14-5		
SN. F33700064 - F33700074	TCM IO-360-GB	RAP215CC	RAP215CC-OH	211CC	RA1J10-1		
SN. F33700075 - F33700086	TCM IO-360-GB	RAP215CC	RAP215CC-OH	211CC	RA1J10-1		
F337 Deice SN. F33700056 and up	TCM IO-360-GB	RAP441CC	RAP441CC-OH				
FT337 Non Deice SN. F3370001 - F3370015	TCM IO-360-GB	RAP215CC	RAP215CC-OH	211CC	RA-D-9-14-5		
SN. F3370016 and up	TCM IO-360-GB	RAP215CC	RAP215CC-OH	211CC	RA1J10-1		
FT337 Deice SN. F3370001 and up	TCM IO-360-GB	RAP441CC	RAP441CC-OH		RA-B3-5-1		
SN. M337B	TCM IO-360-D, -DB	RAP215CC	RAP215CC-OH	211CC			
P337 SN. P3370001 - P3370226	TCM TSIO-360-C, -CB	RAP215CC	RAP215CC-OH	211CC			
P337 Deice SN. P3370053 and up	TCM TSIO-360-C, -CB	RAP441CC	RAP441CC-OH		RA-B3-5-1		
P337H	TCM TSIO-360-C, -DB	RAP215CC	RAP215CC-OH	211CC	RA1J10-1		
P337H cont.	TCM TSIO-360-C, -DB	RAP441CC	RAP441CC-OH				
T337B	TCM TSIO-360-A, -B	RAP215CC	RAP215CC-OH	211CC			
	TCM TSIO-360-A	RAP441CC	RAP441CC-OH				
T337C thru F	TCM TSIO-360-A	RAP215CC	RAP215CC-OH	211CC			
	TCM TSIO-360-A	RAP441CC	RAP441CC-OH				
T337G Non Deice SN. P3370001 - P3370225	TCM TSIO-360-C, -CB	RAP215CC	RAP215CC-OH	211CC	RA-B3-5-1, RA-D-9-14-5		
SN. P3370226	TCM TSIO-360-C, -CB	RAP215CC	RAP215CC-OH	211CC	RA-B3-5-1, RA1J10-1		
T337H Skymaster	TCM TSIO-360H, -HB, -JB	RAP215CC	RAP215CC-OH	211CC	RA1J10-1		
T337H-SP Skymaster	TCM TSIO-360H, -HB, -JB	RAP215CC	RAP215CC-OH	211CC			
340 with Single Instruments	TCM TSIO-520-K, -KB	RAP216CW	RAP216CW-OH	212CW	RA-B3-5-1	RA2H3-5	
340 with Dual Instruments	TCM TSIO-520-K, -KB	RAP442CW	RAP442CW-OH		RA-B3-5-1	RA2H3-5	
340 with Auto Pilot	TCM TSIO-520-K, -KB	RAP242CW	RAP242CW-OH		RA-B3-5-1	RA2H3-5	
340A Non Deice, Single Instruments	TCM TSIO-520-N, -NB	RAP442CW	RAP442CW-OH		RA-B3-5-1	RA2H3-5	
340A with Auto Pilot	TCM TSIO-520-N, -NB	RAP242CW	RAP242CW-OH		RA-B3-5-1	RA2H3-5	
340A Deice	TCM TSIO-520-N, -NB	RAP442CW	RAP442CW-OH		RA-B3-5-1	RA2H3-5	
401, 401A without Auto Pilot, w/ Conv. Kit	TCM TSIO-520-E, -EB	RAP216CW	RAP216CW-OH	212CW	RA-B3-5-1, RA2J4-4	RA2H3-5	
401, 401A with Auto Pilot, w/ Conv. Kit	TCM TSIO-520-E, -EB	RAP242CW	RAP242CW-OH		RA-B3-5-1, RA2J4-4	RA2H3-5	
401B without Auto Pilot SN. 401B0001 - 401B0100	TCM TSIO-520-E, -EB	RAP216CW	RAP216CW-OH	212CW	RA-B3-5-1, RA-D-9-14-5, RA2J4-4	RA2H3-5	
SN. 401B0101 - 401B0300	TCM TSIO-520-E, -EB	RAP216CW	RAP216CW-OH	212CW	RA-B3-5-1, RA2J4-4	RA2H3-5	
401B with Auto Pilot SN. 401B0001 - 401B0100	TCM TSIO-520-E, -EB	RAP242CW	RAP242CW-OH		RA-B3-5-1, RA-D-9-14-5, RA2J4-4	RA2H3-5	
SN. 401B0101 - 401B0300	TCM TSIO-520-E, -EB	RAP242CW	RAP242CW-OH		RA-B3-5-1, RA2J4-4	RA2H3-5	
402 w/ Conversion Kit	TCM TSIO-520-E, -EB	RAP216CW	RAP216CW-OH	212CW	RA-B3-5-1, RA2J4-4	RA2H3-5	
402A without Auto Pilot, w/ Conv. Kit	TCM TSIO-520-E, -EB	RAP216CW	RAP216CW-OH	212CW	RA-B3-5-1, RA-D-9-14-5	RA2H3-5	
402A with Auto Pilot, w/ Conversion Kit	TCM TSIO-520-E, -EB	RAP242CW	RAP242CW-OH		RA-B3-5-1, RA-D-9-14-5, RA2J4-4	RA2H3-5	
402B without Auto Pilot SN. 401B0001 - 401B0100	TCM TSIO-520-E, -EB	RAP216CW	RAP216CW-OH	212CW	RA-B3-5-1, RA-D-9-14-5, RA2J4-4	RA2H3-5	
SN. 401B0101 and up	TCM TSIO-520-E, -EB	RAP216CW	RAP216CW-OH	212CW	RA-B3-5-1, RA2J4-4	RA2H3-5	
402B with Auto Pilot SN. 401B0001 - 401B0100	TCM TSIO-520-E, -EB	RAP242CW	RAP242CW-OH		RA-B3-5-1, RA-D-9-14-5, RA2J4-4	RA2H3-5	
SN. 401B0101 and up	TCM TSIO-520-E, -EB	RAP242CW	RAP242CW-OH		RA-B3-5-1, RA2J4-4	RA2H3-5	
404 Titan	TCM GTSIO-520-M	RAP215CC	RAP215CC-OH	211CC			
411, 411A without Auto Pilot	TCM GTSIO-520-C	RAP215CC	RAP215CC-OH	211CC		RA2H3-5	
with Auto Pilot	TCM GTSIO-520-C	RAP241CC	RAP241CC-OH				
414, 414A Chancellor Vac. Instrument SN. 4140001 - 4140150	TCM TSIO-520-J, -JB, -N, -NB	RAP216CW	RAP216CW-OH		RA-B3-5-1	RA2H3-5	
SN. 4140151 - 4140349	TCM TSIO-520-J, -JB, -N, -NB	RAP216CW	RAP216CW-OH	212CW	RA-B3-5-1	RA2H3-5	
414, 414A with Auto Pilot SN. 4140001 - 4140150	TCM TSIO-520-J, -JB, -N, -NB	RAP242CW	RAP242CW-OH		RA-B3-5-1	RA2H3-5	
SN. 4140151 - 4140349	TCM TSIO-520-J, -JB, -N, -NB	RAP242CW	RAP242CW-OH		RA-B3-5-1	RA2H3-5	
414, 414A Pressure Instr. 4140251 & up	TCM TSIO-520-J, -JB, -N, -NB	RAP216CW	RAP216CW-OH	212CW	RA-B3-5-1	RA2H3-5	
414, 414A w/ Auto Pilot 4140251 & up	TCM TSIO-520-J, -JB, -N, -NB	RAP242CW	RAP242CW-OH		RA-B3-5-1	RA2H3-5	
414A with Dual Instruments	TCM TSIO-520-J, -JB, -N, -NB	RAP442CW	RAP442CW-OH		RA-B3-5-1	RA2H3-5	
414A Deice	TCM TSIO-520-J, -JB, -N, -NB	RAP442CW	RAP442CW-OH		RA-B3-5-1	RA2H3-5	
421, A, B Golden Eagle w/o Auto Pilot SN. 421B0001 - 421B0601	TCM GTSIO-520-D, -H	RAP215CC	RAP215CC-OH	211CC	RA-B3-5-1	RA2H3-5	
SN. 421B0602 and up	TCM GTSIO-520-D, -H	RAP215CC	RAP215CC-OH	211CC			
421, A with Auto Pilot SN. 421B0001 - 421B0601	TCM GTSIO-520-D, -H	RAP241CC	RAP241CC-OH		RA-B3-5-1	RA2H3-5	
SN. 421B0602 and up	TCM GTSIO-520-D, -H	RAP241CC	RAP241CC-OH				
421C Non Deice 1976 thru 1985	TCM GTSIO-520-L, N	RAP215CC	RAP215CC-OH	211CC	RA-B3-5-1	RA2H3-5	
421C Dual Instrument C1097 and up	TCM GTSIO-520-L, N	RAP441CC	RAP441CC-OH		RA-B3-5-1	RA2H3-5	
421C Deice 1976 thru 1985	TCM GTSIO-520-L, N	RAP441CC	RAP441CC-OH		RA-B3-5-1	RA2H3-5	
Commander - see Rockwell							
Daher - see Socata							
de Havilland - see Viking Air Limited (Twin Otter)							
Fairchild / M7 Aerospace							
SA26-AT Merlin IIB	GAR TPE331-151G					RA2H3-2	
SA227-AT, SA227-TT Metro III	GAR TPE331-303G					RA2H3-2	
Grumman American / American Aviation / American General / Gulfstream / Tiger Aircraft							
AA-1, AA-1A Yankee, Trainer	LYC O-235-C	RAP215CC	RAP215CC-OH	211CC	RA1J7-1		
AA-1B Trainer, TC	LYC O-235-C	RAP215CC	RAP215CC-OH	211CC	RA1J7-1	RA2H3-12	
SN. AA-1B-0379 and up	LYC O-235-C	RAP215CC	RAP215CC-OH	211CC		RA2H3-12	
AA-1C, T Cat / Lynx	LYC O-235-L	RAP215CC	RAP215CC-OH	211CC		RA2H3-12	

All Airborne pumps available FAA Approved overhauled. For installation eligibility refer to FAA-PMA Supplement. For reference only.



## REPLACEMENT AIRCRAFT PARTS CO.

## PNEUMATICS APPLICATIONS

Aircraft Manufacturer Model / Serial Number / Option	Engine Manufacturer & Model	Dry Air Pump			Filters	Regulator	Check Valve
		New RAPCO	Overhauled RAPCO	Overhauled OEM			
<b>AA-5 Traveler</b>	LYC O-320-E	RAP215CC	RAP215CC-OH	211CC	RA-B3-5-1, RA1J7-1	RA2H3-12	
<b>AA-5A Cheetah</b>	LYC O-320-E	RAP215CC	RAP215CC-OH	211CC	RA1J7-1	RA2H3-12	
<b>AA-5B Tiger</b>	LYC O-360-A	RAP215CC	RAP215CC-OH	211CC	RA1J7-1	RA2H3-12	
<b>GA-7 Cougar</b>	LYC O-320-D	RAP215CC	RAP215CC-OH	211CC	RA2J4-7		
<b>Gulfstream</b> - also see Aero Commander							
<b>Hawker</b> - see Beech							
<b>Hello</b>							
<b>H295, Courier, SN:1204 and up</b>	LYC GO-480-G	RAP216CW	RAP216CW-OH	212CW	RA-B3-5-1		
<b>500</b>	LYC O-540-A	RAP215CC	RAP215CC-OH	211CC			
<b>HT-595</b>	LYC GO-480-G	RAP216CW	RAP216CW-OH	212CW			
<b>550, Stallion</b>	LYC TIO-540-J	RAP215CC	RAP215CC-OH	211CC			
<b>Lake</b>							
<b>LA-4-200 Buccaneer</b>	LYC O-360-A	RAP215CC	RAP215CC-OH	211CC	RA-B3-5-1, RA1J7-1		
<b>250 Renegade</b>	LYC O-540-C	RAP215CC	RAP215CC-OH	211CC			
<b>Maule</b>							
<b>M-4-180</b>	Franklin 6A-335-B	RAP216CW	RAP216CW-OH	212CW			
<b>M-4-210</b>	TCM IO-360-A, -D	RAP215CC	RAP215CC-OH	211CC	RA-B3-5-1	RA2H3-2	
<b>M-4-220</b>	Franklin 6A-350-C	RAP216CW	RAP216CW-OH	212CW	RA-B3-5-1, RA-D9-18-1	RA2H3-12	
<b>M-5-180C</b>	LYC O-360-C	RAP215CC	RAP215CC-OH	211CC			
<b>M-5-200</b>	LYC IO-360-J	RAP215CC	RAP215CC-OH	211CC			
<b>M-5-235</b>	LYC O-540-J, IO-540-W	RAP215CC	RAP215CC-OH	211CC		RA2H3-12	
<b>M-6-180</b>	LYC O-360-C	RAP215CC	RAP215CC-OH	211CC			
<b>M-6-235</b>	LYC O-540-J, IO-540-W	RAP215CC	RAP215CC-OH	211CC			
<b>M-7-235B, M-7-260, MT-7-235</b>	LYC O-540-W, IO-540-W, -V	RAP215CC	RAP215CC-OH	211CC			
<b>Mitsubishi</b>							
<b>MU-2B-20, -25</b>					RA-B3-5-1	RA2H3-6	
<b>Mooney</b>							
<b>M20</b>	LYC O-320	RAP215CC	RAP215CC-OH	211CC	RA1J7-1		
<b>M20A</b>	LYC O-360-A	RAP215CC	RAP215CC-OH	211CC	RA1J7-1		
<b>M20B SN. 1701B - 1939B</b>	LYC O-360-A	RAP215CC	RAP215CC-OH	211CC	RA1J7-1	RA2H3-12	
<b>M20C SN. 194CC up, 680001 - 680225C</b>	LYC O-360-A	RAP215CC	RAP215CC-OH	211CC	RA-B3-5-1, RA1J7-1	RA2H3-12	
<b>SN. 690001 and up</b>	LYC O-360-A	RAP215CC	RAP215CC-OH	211CC	RA-B3-5-1, RA1J7-1		
<b>M20D SN. 101D and up</b>	LYC O-360-A	RAP215CC	RAP215CC-OH	211CC	RA-B3-5-1, RA1J7-1	RA2H3-12	
<b>M20E SN. 101E and up</b>	LYC IO-360-A	RAP215CC	RAP215CC-OH	211CC	RA-B3-5-1, RA1J7-1	RA2H3-12	
<b>SN. 69001 and up</b>	LYC IO-360-A	RAP215CC	RAP215CC-OH	211CC	RA-B3-5-1, RA1J7-1		
<b>M20F SN. 670001 - 680215</b>	LYC IO-360-A	RAP215CC	RAP215CC-OH	211CC	RA-B3-5-1, RA1J7-1	RA2H3-12	
<b>SN. 690001 and up</b>	LYC IO-360-A	RAP215CC	RAP215CC-OH	211CC	RA-B3-5-1, RA1J7-1		
<b>M20G SN. 680001 - 680205</b>	LYC IO-360-A	RAP215CC	RAP215CC-OH	211CC	RA-B3-5-1, RA1J7-1	RA2H3-12	
<b>SN. 690001 - 70006</b>	LYC IO-360-A	RAP215CC	RAP215CC-OH	211CC	RA-B3-5-1, RA1J7-1		
<b>M20J SN. 24-0001 thru 24-1604</b>	LYC IO-360-A	RAP215CC	RAP215CC-OH	211CC	RA-B3-5-1, RA-D9-18-1	RA2H3-12	
<b>SN. 24-1605 and up</b>	LYC IO-360-A	RAP215CC	RAP215CC-OH	211CC	RA-B3-5-1, RA-D9-18-1, RA2J4-6	RA2H3-12	
<b>SN. 24-0001 - 24-2999 (Standby System)</b>	LYC IO-360-A	RAP216CW	RAP216CW-OH	212CW	RA-B3-5-1		
<b>SN. 24-3000 and up (Standby System)</b>	LYC IO-360-A	RAP215CC	RAP215CC-OH	211CC	RA-B3-5-1		
<b>M20K with Single Alternator SN. 25-1001 thru 25-1087</b>	TCM TSIO-360-G, -L, -M, -S	RAP215CC	RAP215CC-OH	211CC	RA-B3-5-1	RA2H3-12	
<b>SN. 25-1088 and up</b>	TCM TSIO-360-G, -L, -M, -S	RAP241CC	RAP241CC-OH				
<b>M20K (231, 252) with Dual Alt. SN. 25000 and up</b>	TCM TSIO-360-G, -L, -M, -S	RAP215CC	RAP215CC-OH	211CC	RA-B3-5-1, RA-D9-18-1	RA2H3-12	
<b>M20K with Standby Sys. SN. 25-1001 up</b>	TCM TSIO-360-G, -L, -M, -S	RAP241CC	RAP241CC-OH		RA2J4-6		
<b>M20M</b>	TCM TSIO-360-G, -L, -M, -S	RAP216CW	RAP216CW-OH	212CW	RA-B3-5-1	RA2H3-12	
<b>M20R</b>	LYC TIO-540-A	RAP241CC-15	RAP241CC-15-OH		RA-B3-5-1, RA-D9-18-1, RA2J4-6		
<b>M22</b>	TCM IO-550-G	RAP242CW	RAP242CW-OH		RA-B3-5-1, RA-D9-18-1, RA2J4-6		
	LYC TIO-541	RAP216CW	RAP216CW-OH	212CW	RA-B3-5-1, RA1J7-1		
<b>Navion</b>							
<b>G</b>	TCM IO-470-H	RAP216CW	RAP216CW-OH	212CW	RA-B3-5-1		
<b>H</b>	TCM IO-520-B	RAP216CW	RAP216CW-OH	212CW	RA-B3-5-1		
<b>Partenavia</b> - see Vulcanair							
<b>Piaggio</b>							
<b>P.136-L</b>	LYC GO-435-C2B	RAP216CW	RAP216CW-OH	212CW			
<b>Pilatus BN</b> - see Britten Norman							
<b>Piper / The New Piper Aircraft Inc.</b>							
<b>J5C</b>	LYC O-235-C	RAP215CC	RAP215CC-OH	211CC			
<b>PA-12, PA-12S</b>	LYC O-235-C	RAP215CC	RAP215CC-OH	211CC			
<b>PA-14</b>	LYC O-235-C1	RAP215CC	RAP215CC-OH	211CC			
<b>PA-16, -16S</b>	LYC O-235-C1	RAP215CC	RAP215CC-OH	211CC			
<b>PA-18 Super Cub SN. 18-8020 thru 18-7609012</b>	LYC O-235-C, O-290-D, 0-320	RAP215CC	RAP215CC-OH	211CC	RA-B3-5-1	RA2H3-23	
<b>SN. 18-7609013 and up</b>	LYC O-235-C, O-290-D, 0-320	RAP215CC	RAP215CC-OH	211CC	RA-B3-5-1, RA1J7-1	RA2H3-23	
<b>SN. 189001 and up</b>	LYC O-235-C, O-290-D, 0-320	RAP215CC	RAP215CC-OH	211CC	RA-B3-5-1, RA1J7-1	RA2H3-23	
<b>PA-20-115, PA-20S-115</b>	LYC O-235-C	RAP215CC	RAP215CC-OH	211CC			
<b>PA-20, -20S, -20-135, -20S-135,</b>	LYC O-290-D, -D2	RAP215CC	RAP215CC-OH	211CC			
<b>PA-22</b>	LYC O-290-D, -D2	RAP215CC	RAP215CC-OH	211CC			
<b>PA-22-108 Tri Pacer SN. 22-8000 thru 22-8709</b>	LYC O-235-C	RAP215CC	RAP215CC-OH	211CC			
<b>SN. 22-8710 and up</b>	LYC O-235-C	RAP215CC	RAP215CC-OH	211CC	RA-B3-5-1	RA2H3-12	

All Airborne pumps available FAA Approved overhauled. For installation eligibility refer to FAA-PMA Supplement. For reference only.



**PNEUMATICS APPLICATIONS**

Aircraft Manufacturer Model / Serial Number / Option	Engine Manufacturer & Model	Dry Air Pump			Filters	Regulator	Check Valve
		New RAPCO	Overhauled RAPCO	Overhauled OEM			
PA-22-135, PA-22S-135	LYC O-290-D	RAP215CC	RAP215CC-OH	211CC			
PA-22-150, PA-22S-150	LYC O-320-A, -B	RAP215CC	RAP215CC-OH	211CC			
PA-22-160, PA-22S-160	LYC O-320-A, -B	RAP215CC	RAP215CC-OH	211CC			
PA-23-160 Apache	LYC O-320-A, -B, -C	RAP215CC	RAP215CC-OH	211CC	RA-B3-5-1		
SN. 23-2395 and up	LYC O-320-A, -B, -C				RA-B3-5-1	RA2H3-2	
PA-23-235 Aztec	LYC O-540-A	RAP215CC	RAP215CC-OH	211CC	RA-B3-5-1, RA-D9-18-1		
PA-23-235 Deice	LYC O-540-A	RAP441CC-7	RAP441CC-7-OH				
PA-23-250 Non Deice, Pilot Instruments SN. 27-2000 thru 27-2504	LYC O-540-A	RAP215CC	RAP215CC-OH	211CC	RA-B3-5-1, RA-D9-18-1		
SN. 27-2505 thru 27-7654001	LYC O-540-A	RAP215CC	RAP215CC-OH	211CC	RA-B3-5-1, RA-D9-18-1		
PA-23-250 Non Deice, Dual Instruments SN. 27-7654001 and up	LYC O-540-A	RAP441CC-7	RAP441CC-7-OH		RA-B3-5-1, RA-D9-18-1		
PA-23-250 Deice - BFG System SN. 27-4510 thru 27-7304963	LYC O-540-A	RAP441CC-7	RAP441CC-7-OH		RA-B3-5-1, RA-D9-18-1		
SN. 27-7304964 thru 27-7654001	LYC O-540-A	RAP441CC-7	RAP441CC-7-OH		RA-B3-5-1, RA-D9-18-1		
PA-23-250 Deice - Airborne System SN. 27-7554112 - 27-7554168	LYC O-540-A	RAP441CC-7	RAP441CC-7-OH				
PA-24-180 Comanche	LYC O-360-A	RAP215CC	RAP215CC-OH	211CC	RA-B3-5-1		
SN. 24-2176, 24-2177, 24-2179 - 24-2184	LYC O-360-A	RAP215CC	RAP215CC-OH	211CC	RA-B3-5-1		
S. 24-2186 - 24-2202, 24-2204 - 24-2218	LYC O-360-A	RAP215CC	RAP215CC-OH	211CC	RA-B3-5-1		
SN. 24-2222, 24-2999 thru 24-2587	LYC O-360-A	RAP215CC	RAP215CC-OH	211CC	RA-B3-5-1		
SN. 24-2563, 24-2588 and up	LYC O-360-A	RAP215CC	RAP215CC-OH	211CC	RA-B3-5-1, RA-D9-18-1		
PA-24-250 Comanche	LYC O-540-A, IO-540-C	RAP215CC	RAP215CC-OH	211CC	RA-D9-18-1		
SN. 24-2563, 24-2588 and up	LYC IO-540-D, -N, -R	RAP215CC	RAP215CC-OH	211CC	RA-D9-18-1	RA2H3-12	
PA-24-260 Comanche	LYC O-540-D, -E -N, -R	RAP215CC	RAP215CC-OH	211CC	RA-B3-5-1, RA-D9-18-1	RA2H3-12	
PA-24-400 Comanche	LYC IO-720	RAP215CC	RAP215CC-OH	211CC		RA2H3-12	
PA-25 Pawnee	LYC O-320, -A	RAP215CC	RAP215CC-OH	211CC			
PA-25-235, -260	LYC O-540-B, -G	RAP215CC	RAP215CC-OH	211CC			
PA-28-140 Cherokee	LYC O-320-E	RAP215CC	RAP215CC-OH	211CC	RA-B3-5-1, RA-D9-18-1	RA2H3-12	
SN. 28-20002 thru 28-7425454							
SN. 28-7585001 and up	LYC O-320-E	RAP215CC	RAP215CC-OH	211CC	RA-B3-5-1, RA-D9-18-1	RA2H3-19	
PA-28-150	LYC O-320-A, -E	RAP215CC	RAP215CC-OH	211CC	RA-B3-5-1, RA-D9-18-1	RA2H3-12	
PA-28-151 Warrior	LYC O-320-E	RAP215CC	RAP215CC-OH	211CC	RA-B3-5-1, RA-D9-18-1	RA2H3-12	
SN. 28-7415001 thru 28-7415713							
SN. 28-7415001 thru 28-7715314	LYC O-320-E	RAP215CC	RAP215CC-OH	211CC	RA-B3-5-1, RA-D9-18-1	RA2H3-19	
PA-28-160 Cherokee	LYC O-320-D	RAP215CC	RAP215CC-OH	211CC	RA-B3-5-1, RA-D9-18-1	RA2H3-12	
PA-28-161 Warrior	LYC O-320-D	RAP215CC	RAP215CC-OH	211CC	RA-B3-5-1, RA-D9-18-1	RA2H3-19	
PA-28-161 with Aux. Pump System	LYC O-320-D	RAP215CC	RAP215CC-OH	211CC	RA-B3-5-1, RA-D9-18-1	RA2H3-19	
PA-28-180, PA-28S-180	LYC O-360-A	RAP215CC	RAP215CC-OH	211CC	RA-B3-5-1, RA-D9-18-1	RA2H3-12	
SN. 28-7105001 thru 28-7406290							
SN. 28-7405001 thru 28-7505261	LYC O-360-A	RAP215CC	RAP215CC-OH	211CC	RA-B3-5-1, RA-D9-18-1	RA2H3-12	
PA-28-181 Archer II 28-760001 and up	LYC O-360-A	RAP215CC	RAP215CC-OH	211CC	RA-B3-5-1, RA-D9-18-1	RA2H3-19	
PA-28-181 Archer III 28-90206 and up	LYC O-360-A	RAP215CC	RAP215CC-OH	211CC	RA-B3-5-1, RA-D9-18-1	RA2H3-19	
PA-28-201T Turbo Dakota	TCM TSIO-360-F	RAP215CC	RAP215CC-OH	211CC	RA-B3-5-1, RA-D9-18-1	RA2H3-19	
SN. 28-7921001 thru 28-7921091							
PA-28R-180 Arrow	LYC IO-360-B	RAP215CC	RAP215CC-OH	211CC	RA-B3-5-1, RA-D9-18-1	RA2H3-12	
SN. 28R-30005 thru 28-R7130019							
SN. 28R-75350001 and up	LYC IO-360-B	RAP215CC	RAP215CC-OH	211CC	RA-B3-5-1, RA-D9-18-1	RA2H3-19	
PA-28R-200 Arrow	LYC IO-360-C	RAP215CC	RAP215CC-OH	211CC	RA-B3-5-1	RA2H3-12	
SN. 28R-30482, 28R-35001 - 28R-35830							
SN. 28R-7135001 thru 28R-7475331	LYC IO-360-C	RAP215CC	RAP215CC-OH	211CC	RA-B3-5-1	RA2H3-12	
SN. 28R-7535001 and up	LYC IO-360-C	RAP215CC	RAP215CC-OH	211CC	RA-B3-5-1	RA2H3-19	
PA-28R-201 Arrow	LYC IO-360-C	RAP215CC	RAP215CC-OH	211CC	RA-B3-5-1, RA-D9-18-1	RA2H3-19	
SN. 28R-7737002 - 28R-7837317							
SN. 28R-7837318 and up	LYC IO-360-C	RAP215CC	RAP215CC-OH	211CC	RA-B3-5-1, RA-D9-18-1	RA2H3-19	
SN. 2803001 and up Aux. Pump		RAP215CC	RAP215CC-OH	211CC			
PA-28R-201T Turbo Arrow	TCM TSIO-360-F	RAP215CC	RAP215CC-OH	211CC	RA-B3-5-1, RA-D9-18-1	RA2H3-19	
SN. 28R-7703001 thru 28R-7803373							
SN. 28R-7803374 and up	TCM TSIO-360-F	RAP215CC	RAP215CC-OH	211CC	RA-B3-5-1, RA-D9-18-1	RA2H3-19	
SN. 2803001 and up Aux. Pump		RAP215CC	RAP215CC-OH	211CC			
PA-28RT-201 Arrow IV	LYC IO-360-C	RAP215CC	RAP215CC-OH	211CC	RA-B3-5-1, RA-D9-18-1	RA2H3-19	
SN. 28RT-7918001 thru 28R-8218026							
PA-28RT-201	LYC IO-360-C	RAP215CC	RAP215CC-OH	211CC	RA-B3-5-1, RA-D9-18-1	RA2H3-19	
SN. 28RT-8218027 thru 28R-8218039							
PA-28RT-201T 28R-7931001 and Up	TCM TSIO-360-F	RAP215CC	RAP215CC-OH	211CC	RA-B3-5-1, RA-D9-18-1	RA2H3-19	
PA-28-235 Cherokee 235, Pathfinder	LYC O-540-B	RAP215CC	RAP215CC-OH	211CC	RA-B3-5-1, RA-D9-18-1	RA2H3-12	
SN. 28-10003 thru 28-11039							
PA-28-236 Dakota	LYC O-540-J	RAP215CC	RAP215CC-OH	211CC	RA-B3-5-1, RA-D9-18-1	RA2H3-19	
PA-28-236 with Aux. Pump System SN. 28-7911001 and up		RAP215CC	RAP215CC-OH	211CC	RA-B3-5-1	RA2H3-19	
PA-30 Twin Comanche SN. 30-2 Up	LYC IO-320-B	RAP215CC	RAP215CC-OH	211CC	RA-B3-5-1, RA-D9-18-1		
C/R Option Right Engine, Also see PA-39	LYC LIO-320-B			212CW	RA-B3-5-1		
PA-31-300 Navajo Non Deice, Pilot Instruments only	LYC IO-540-M	RAP215CC	RAP215CC-OH	211CC	RA-B3-5-1, RA2J4-6		
PA-31-300 Non Deice, Dual Instruments SN. 31-5 thru 31-854	LYC IO-540-M	RAP441CC-7	RAP441CC-7-OH		RA-B3-5-1, RA2J4-6		
SN. 31-855 thru 31-7612018	LYC IO-540-M	RAP441CC-7	RAP441CC-7-OH		RA2J4-6		
PA-31-300 Deice	LYC IO-540-M	RAP441CC-7	RAP441CC-7-OH		RA-B3-5-1, RA2J4-6		
PA-31 (310) Navajo Non Deice, Pilot Instruments	LYC TIO-540-A	RAP215CC	RAP215CC-OH	211CC	RA-B3-5-1, RA2J4-6		
PA-31 (310) Non Deice, Dual instruments	LYC TIO-540-A	RAP441CC-7	RAP441CC-7-OH		RA-B3-5-1, RA2J4-6		
PA-31 (310) Deice	LYC TIO-540-A	RAP441CC-7	RAP441CC-7-OH		RA-B3-5-1, RA2J4-6		
C/R Option Right Engine & Wing Locker	LYC LTIO-540-A	RAP442CW-6 (Right)	RAP442CW-6-OH		RA-B3-5-1, RA2J4-6		
PA-31-325 Navajo C/R Non Deice, Pilot Instruments	LYC TIO-540-F	RAP215CC (Left)	RAP215CC-OH	211CC	RA-B3-5-1, RA2J4-6		
Non Deice, Pilot Instruments	LYC LTIO-540-F			212CW (Right)	RA-B3-5-1, RA2J4-6		
PA-31-325 Non Deice, Dual Instruments	LYC TIO-540-F	RAP441CC-7 (Left)	RAP441CC-7-OH		RA-B3-5-1, RA2J4-6		
	LYC LTIO-540-F	RAP442CW-6 (Right)	RAP442CW-6-OH		RA-B3-5-1, RA2J4-6		
PA-31-325 Deice	LYC TIO-540-F	RAP441CC-7 (Left)	RAP441CC-7-OH		RA-B3-5-1, RA2J4-6		
	LYC LTIO-540-F	RAP442CW-6 (Right)	RAP442CW-6-OH		RA-B3-5-1, RA2J4-6		

All Airborne pumps available FAA Approved overhauled. For installation eligibility refer to FAA-PMA Supplement.

For reference only.



Aircraft Manufacturer Model / Serial Number / Option	Engine Manufacturer & Model	Dry Air Pump			Filters	Regulator	Check Valve
		New RAPCO	Overhauled RAPCO	Overhauled OEM			
<b>PA-31-350 Chieftain</b> Non Deice, Pilot Instruments only SN. 31-5001 thru 31-7652123 SN. 31-7652124 and up	LYC TIO-540-J LYC LTIO-540-J	RAP215CC (Left)	RAP215CC-OH	211CC 212CW (Right)	RA2J4-6 RA2J4-6		
Non Deice, Dual Instruments SN. 31-5001 thru 31-7652123 SN. 31-7652124 and up	LYC TIO-540-J LYC LTIO-540-J	RAP441CC-7 (Left) RAP442CW-6 (Right)	RAP441CC-7-OH RAP442CW-6-OH	211CC 212CW (Right)	RA2J4-6 RA2J4-6	RA-B3-5-1, RA2J4-6 RA-B3-5-1, RA2J4-6	
<b>PA-31-350 Deice</b> SN. 31-5001 thru 31-7652123 SN. 31-7652124 thru 31-7952250 with Kit 764016 or 764017	LYC TIO-540-J LYC LTIO-540-J	RAP441CC-7 (Left) RAP442CW-6 (Right)	RAP441CC-7-OH RAP442CW-6-OH	211CC 212CW (Right)	RA2J4-6 RA2J4-6	RA-B3-5-1, RA2J4-6 RA-B3-5-1, RA2J4-6	
<b>PA-31P Pressurized Navajo, Deice</b> <b>PA-31P-350 Mojave</b> SN. 31P-8414001 Up Non Deice, Pilot Instruments	LYC TIGO-540-E LYC TIO-540-V LYC LTIO-540-V						
<b>PA-31P-350 Mojave</b> SN. 31P-8414001 Up De-ice and or Dual Instruments	LYC TIO-540-V LYC LTIO-540-V	RAP441CC-7 (Left) RAP442CW-6 (Right)	RAP441CC-7-OH RAP442CW-6-OH		RA2J4-6 RA2J4-6		
<b>PA-31T Cheyenne</b> <b>PA-31T2</b> SN. 31T-8166001 and up	PW PT6A-28 PW PT6A-135						
<b>PA-32-260 Cherokee Six</b> SN. 32-1 - 32-450 SN. 32-451 - 32-7400061 SN. 32-7500001 - 32-7800008	LYC O-540-E LYC O-540-E	RAP215CC RAP215CC	RAP215CC-OH RAP215CC-OH	211CC 211CC		RA-B3-5-1 RA-B3-5-1, RA-D9-18-1	RA2H3-12 RA2H3-12
<b>PA-32-300 Cherokee Six</b> SN. 23-40000 - 32-40292 SN. 32-40293 - 32-744182 SN. 32-7540001 - 32-7940282	LYC IO-540-K LYC IO-540-K	RAP215CC RAP215CC	RAP215CC-OH RAP215CC-OH	211CC 211CC		RA-B3-5-1 RA-B3-5-1, RA-D9-18-1	RA2H3-12 RA2H3-12
<b>PA-32R-300, -32RT-300, -32S-300</b> <b>PA-32RT-300T</b> <b>PA-32-301 Saratoga</b> SN. 32-8006001 up <b>PA-32-301T</b> SN. 32-8024001 and up	LYC IO-540-K LYC TIO-540-S LYC IO-540-K LYC TIO-540-S	RAP215CC RAP215CC RAP215CC RAP215CC	RAP215CC-OH RAP215CC-OH RAP215CC-OH RAP215CC-OH	211CC 211CC 211CC 211CC		RA-B3-5-1, RA-D9-18-1 RA-B3-5-1, RA-D9-18-1	RA2H3-19 RA2H3-19
<b>PA-32R-301</b> <b>PA-32R-301T</b> Non Deice <b>PA-32R-301T</b> Deice	LYC IO-540-K LYC TIO-540-S LYC TIO-540-S	RAP215CC RAP215CC RAP442CW-6	RAP215CC-OH RAP215CC-OH RAP442CW-6-OH	211CC 211CC 212CW		RA-B3-5-1, RA-D9-18-1 RA-B3-5-1, RA-D9-18-1	RA2H3-19 RA2H3-19
<b>PA-34-200 Seneca</b> Non Deice LYC IO-360-C LYC LIO-360-C	LYC IO-360-C LYC LIO-360-C	RAP215CC (Left) RAP216CW (Right)	RAP215CC-OH RAP216CW-OH	211CC 212CW		RA-B3-5-1, RA-D9-18-1	
<b>PA-34-200</b> Deice LYC IO-360-C LYC LIO-360-C	LYC IO-360-C LYC LIO-360-C	RAP441CC-7 (Left) RAP442CW-6, Right	RAP441CC-7-OH RAP442CW-6-OH	211CC		RA-B3-5-1, RA-D9-18-1	
<b>PA-34-200T Seneca II</b> Non Deice SN. 34-7570001 thru 34-7870492 SN. 34-7970001 thru 34-8170092	TCM TSIO-360-E TCM LTSIO-360-E TCM TSIO-360-E TCM LTSIO-360-E	RAP215CC (Left)	RAP215CC-OH	211CC 212CW (Right)		RA-B3-5-1, RA2J4-6 RA2J4-6, RA-D-9-14-5	
<b>PA-34-200T</b> Deice SN. 34-7570001 thru 34-8070037 SN. 34-8070038 thru 34-8170092	TCM TSIO-360-E TCM LTSIO-360-E TCM TSIO-360-E TCM LTSIO-360-E	RAP441CC-7 (Left) RAP442CW-6 (Right) RAP441CC-7 (Left) RAP442CW-6 (Right)	RAP441CC-7-OH RAP442CW-6-OH RAP441CC-7-OH RAP442CW-6-OH	211CC 212CW (Right)		RA-B3-5-1, RA2J4-6 RA2J4-6, RA-D-9-14-5	
<b>PA-34-200T</b> Deice, Dual Instruments SN. 34-7570001 thru 34-7870492 SN. 34-7970001 thru 34-8170092	TCM TSIO-360-E TCM LTSIO-360-E TCM TSIO-360-E TCM LTSIO-360-E	RAP441CC-7 (Left) RAP442CW-6 (Right) RAP441CC-7 (Left) RAP442CW-6 (Right)	RAP441CC-7-OH RAP442CW-6-OH RAP441CC-7-OH RAP442CW-6-OH	211CC 212CW (Right)		RA-B3-5-1, RA2J4-6 RA2J4-6, RA-D-9-14-5	
<b>PA-34-220T Seneca</b> Non Deice TCM TSIO-360-K TCM LTSIO-360-K	TCM TSIO-360-K TCM LTSIO-360-K	RAP215CC, Left	RAP215CC-OH	211CC 212CW (Right)		RA-B3-5-1, RA-D9-18-1	
<b>PA-34-220T</b> Deice TCM TSIO-360-K TCM LTSIO-360-K	TCM TSIO-360-K TCM LTSIO-360-K	RAP441CC-7 (Left) RAP442CW-6 (Right)	RAP441CC-7-OH RAP442CW-6-OH	212CW		RA-B3-5-1, RA-D9-18-1	
<b>PA-36-300 Brave</b> LYC IO-540-K	LYC IO-540-K	RAP215CC	RAP215CC-OH	211CC			
<b>PA-38-112 Tomahawk</b> LYC O-235-L2C	LYC O-235-L2C	RAP215CC	RAP215CC-OH	211CC		RA-B3-5-1, RA-D9-18-1	RA2H3-23
<b>PA-39 Twin Comanche C/R</b> , Also see PA-30	LYC IO-320-B LYC LIO-320-B	RAP215CC (Left)	RAP215CC-OH	211CC 212CW (Right)		RA-B3-5-1, RA-D9-18-1	
<b>PA-40 Arapaho</b> Non Deice LYC IO-320-B LYC LIO-320-B	LYC IO-320-B LYC LIO-320-B	RAP215CC (Left)	RAP215CC-OH	211CC 212CW (Right)			
<b>PA-42-720 Cheyenne III</b> PW PT6A-41	PW PT6A-41					RA-D9-18-1	
<b>PA-42-1000 Cheyenne IV</b> GAR TPE-331	GAR TPE-331					RA-D9-18-1	
<b>PA-44-180 Seminole</b> LYC O-360-A, -E LYC LO-360-E	LYC O-360-A, -E LYC LO-360-E	RAP215CC (Left)	RAP215CC-OH	211CC 212CW (Right)		RA-D9-18-1	
<b>PA-44-180T Turbo Seminole</b> Non Deice LYC TO-360-E LYC LTO-360-E	LYC TO-360-E LYC LTO-360-E			211CC 212CW (Right)		RA-D9-18-1	
<b>PA-44-180T</b> Deice LYC TO-360-E LYC LTO-360-E	LYC TO-360-E LYC LTO-360-E	RAP441CC-7 (Left) RAP442CW-6 (Right)	RAP441CC-7-OH RAP442CW-6-OH			RA-D9-18-1	
<b>PA-46-310P Malibu</b> Non Deice, Single Pump System Non Deice with Standby System	TCM TSIO-520-B TCM TSIO-520-B	RAP216CW RAP442CW-6 (Right)	RAP216CW-OH RAP442CW-6-OH	212CW		RA-B3-5-1, RA-D9-18-1 RA-B3-5-1, RA-D9-18-1	RA2H3-6
<b>PA-46-310P</b> Deice TCM TSIO-520-B	TCM TSIO-520-B	RAP442CW-6 (Right)	RAP442CW-6-OH	212CW		RA-B3-5-1, RA-D9-18-1	
<b>PA-46-350</b> Non Deice, Single Pump LYC TIO-540-AE	LYC TIO-540-AE	RAP216CW	RAP216CW-OH	212CW		RA-B3-5-1, RA-D9-18-1	
<b>PA-46-350P Malibu Mirage</b> Dual Pump LYC TIO-540-AE	LYC TIO-540-AE	RAP441CC-17 (Upper) RAP442CW-6 (Lower)	RAP441CC-17-OH RAP442CW-6-OH			RA-B3-5-1, RA-D9-18-1	RA2H3-6
<b>PA-60 Series</b> - see Aerostar							
<b>Raytheon</b> - see Beech							
<b>Rockwell / Gulfstream / Commander</b>							
<b>112 Commander</b> LYC O-360-C	LYC O-360-C	RAP215CC	RAP215CC-OH	211CC		RA-B3-5-1, RA-D9-18-1	RA2H3-12
<b>112A</b> LYC IO-360-C	LYC IO-360-C	RAP215CC	RAP215CC-OH	211CC			
<b>112B Alpine</b> LYC IO-360-C	LYC IO-360-C	RAP215CC	RAP215CC-OH	211CC		RA-B3-5-1, RA-D9-18-1	RA2H3-12
<b>112TC</b> LYC TO-360-C	LYC TO-360-C			211CC		RA-B3-5-1, RA-D9-18-1	RA2H3-12
<b>112TCA</b> LYC TO-360-C	LYC TO-360-C			211CC		RA-B3-5-1, RA-D9-18-1	RA2H3-12
<b>114, 114A Gran Turismo</b> LYC IO-540-T	LYC IO-540-T	RAP215CC	RAP215CC-OH	211CC		RA-B3-5-1, RA-D9-18-1	RA2H3-12
<b>500 thru 700 Series</b> - see Aero Commander							

All Airborne pumps available FAA Approved overhauled. For installation eligibility refer to FAA-PMA Supplement. For reference only.



### PNEUMATICS APPLICATIONS

Aircraft Manufacturer Model / Serial Number / Option	Engine Manufacturer & Model	Dry Air Pump			Filters	Regulator	Check Valve
		New RAPCO	Overhauled RAPCO	Overhauled OEM			
<b>Socata / Aerospatiale</b>							
<b>MS88B</b>	TCM O-200-A	RAP215CC-9	RAP215CC-9-OH	211CC			
<b>MS892A-150 &amp; E-150</b>	LYC O-320-E	RAP215CC	RAP215CC-OH	211CC			
<b>MS893A, E</b>	LYC O-360-A	RAP215CC	RAP215CC-OH	211CC			
<b>MS894A, E</b>	Franklin 6A-350-C	RAP216CW	RAP216CW-OH	212CW			
<b>I00S</b>	TCM O-200-A	RAP215CC-9	RAP215CC-9-OH	211CC-9			
<b>150T, ST</b>	LYC O-320-E	RAP215CC	RAP215CC-OH	211CC			
<b>235E</b>	LYC O-540-B	RAP215CC	RAP215CC-OH	211CC			
<b>TB9</b> SN. 001 - 822, 850 - 947 except 888	LYC O-320-D	RAP215CC	RAP215CC-OH	211CC	RA-B3-5-1, RA-D9-18-1	RA2H3-12	
<b>TB10 Tobago</b> Aux. Backup Sys. SN. 984 and up	LYC O-360-A	RAP215CC	RAP215CC-OH	211CC	RA-B3-5-1, RA-D9-18-1	RA2H3-12	
<b>TB20 Trinidad</b> Aux. Backup Sys. SN. 984 and up	LYC O-540-C	RAP215CC	RAP215CC-OH	211CC	RA-B3-5-1, RA-D9-18-1	RA2H3-12	
<b>TB21 Trinidad Turbo</b>	LYC TIO-540-A				RA-B3-5-1, RA-D9-18-1	RA2H3-12	
<b>SIAI - Marchetti</b>							
<b>S.205-18/F, /R</b>	LYC O-360-A	RAP215CC	RAP215CC-OH	211CC			
<b>S.205-20/F, /R</b>	LYC O-360-A	RAP215CC	RAP215CC-OH	211CC			
<b>S.205-22/R</b>	Franklin 6A-350-C	RAP216CW	RAP216CW-OH	212CW			
<b>S.208/-A, F.260/-B/-C</b>	LYC O-540-E	RAP215CC	RAP215CC-OH	211CC			
<b>S.210</b>	LYC TIO-360-A	RAP215CC	RAP215CC-OH	211CC			
<b>Ted Smith Aerostar - see Areostar</b>							
<b>Textron Aviation Inc. - see Beech or Cessna</b>							
<b>Twin Comander - see Aero Comander</b>							
<b>Viking Air Limited / de Havilland (Twin Otter)</b>							
<b>DHC-6-1, -100, -200, -300, -400</b>					RA2J4-4		
<b>Vulcanair / Partenavia</b>							
<b>P68, P68B, P68C Observer</b>	LYC IO-360-A	RAP215CC	RAP215CC-OH	211CC	RA1J7-1	RA2H3-12	RA1H5-1
<b>P68, P68B, P68C Deice</b>	LYC IO-360-A	RAP441CC-23	RAP441CC-23-OH			RA2H3-12	
<b>P68C-TC</b>	LYC IO-360-C	RAP215CC	RAP215CC-OH	211CC	RA1J7-1	RA2H3-12	RA1H5-1
<b>P68C-TC Deice</b>	LYC IO-360-C	RAP441CC-23	RAP441CC-23-OH			RA2H3-12	
<b>AP68TP300, AP68TP600 Spartacus</b>	RR 250 B17C				RA1J7-1	RA2H3-12	RA1H5-1

52725



**Section 2:**

**Dry Air Pump Application Guide  
Kit Plane, Experimental and Classic Aircraft Engines**

Engine Manufacturer	Engine Model	Dry Air Pump		
		New RAPCO	Overhaul RAPCO	Overhaul OEM
Continental	C90-16F	RAP215CC-9	RAP215CC-9-OH	211CC-9
	O-200-A thru -C	RAP215CC-9	RAP215CC-9-OH	211CC-9
	IO-240	RAP216CW	RAP216CW-OH	212CW
	IO-360	RAP215CC	RAP215CC-OH	211CC
	IO-520	RAP216CW	RAP216CW-OH	212CW
	IO-550	RAP216CW	RAP216CW-OH	212CW
Franklin	6A-235-B	RAP216CW	RAP216CW-OH	212CW
	6A-350-C	RAP216CW	RAP216CW-OH	212CW
Jabiru	2200	RAP216CW	RAP216CW-OH	212CW
	2300	RAP216CW	RAP216CW-OH	212CW
Lycoming	O-235	RAP215CC	RAP215CC-OH	211CC
	O-290	RAP215CC	RAP215CC-OH	211CC
	O-320	RAP215CC	RAP215CC-OH	211CC
	O-360	RAP215CC	RAP215CC-OH	211CC
	IO-360	RAP215CC	RAP215CC-OH	211CC
	O-540	RAP215CC	RAP215CC-OH	211CC
Pratt & Whitney	R-985	RAP216CW	RAP216CW-OH	212CW
	R-1340	RAP216CW	RAP216CW-OH	212CW
Rotax	912	RAP215CC	RAP215CC-OH	211CC
	914	RAP215CC	RAP215CC-OH	211CC

For reference only.

111424

**Section 3:**

**Beech King Air Rudder Boost Filter Replacement  
RAPCO PN. RA101-524009-0163 - Rudder Boost Filter**

FAA-PMA approved replacement for the following part numbers.  
101-524009-91, 101-524009-0161 & 101-524009-0163

Application
C90A, C90GT, C90GTi,
A100-1 (U-21J),
200, 200C, 200CT, 200T,
A200 (C-12A), (C-12C),
A200C (UC-12B),
A200CT (C-12D), (FWC-12D), (C-12F), (RC-12D), (RC-12G), (RC-12H), (RC-12K), (RC-12P), (RC-12Q),
B200,
B200C (C-12F), (UC-12M), (C-12R), (UC-12F),
B200CT
B200T
B200GT,
B200CGT

**PNEUMATICS CROSS REFERENCE**

**Filters**

RAPCO		Airborne or OEM		Aero Acc. / Tempest PN.	Beech PN.	Cessna PN.	Piper PN.	Description
Latest PN.	Superseded	Latest PN.	Superseded					
RA-B3-5-1	-	B3-5-1	B3005A1	AAB3-5-1	-	C482001-0202	751 815	Regulator Garter, Foam, 1" Long x 1 3/4" Dia.
RA-D9-14-3	-	D9-14-3	-	AAD9-14-3	-	-	-	Element for 1J2 Series, 2 3/16" Long x 2 7/8" Dia
RA-D-9-14-5	-	D9-14-5	-	AAD9-14-5	8398 136-05-0H	C294501-0103	757 899	Element for 1J2 Series Except 1J2-2, 2 3/16" L x 2 7/8" D
RA-D9-18-1	-	D9-18-1	-	AAD9-18-1	-	C294502-0201	757 899	Element for RA1J7-1 Assembly 3" Long x 3 1/4" Dia.
RA1J7-1	-	1J7-1	-	AA1J7-1	-	-	460 888	Vac.Filter Assy. Two 3/8" tubes, 3 3/4" Long X 2 7/8" Dia.
RA1J10-1	-	1J10-1	-	-	-	C294502-0101	-	Line Mounted - two 3/8" tubes, 5 1/4" Long X 3" Dia.
RA2J4-4	RA1J4-4	2J4-4	1J4-4	AA2J4-4	-	200441	460 857	Line Mounted - two 1/2" tubes, 5" Long X 3 1/4" Dia.
-	-	-	-	-	-	201442	460 888	-
-	-	-	-	-	-	J-158444	-	-
RA2J4-6	RA1J4-6	2J4-6	1J4-6	AA2J4-6	92-301-126	-	460 866	Line Mounted - two 5/8" tubes, 6 3/4" Long X 3 1/4" Dia.
-	-	-	-	-	-	-	560 689	-
RA2J4-7	RA1J4-7	2J4-7	1J4-7	AA2J4-7	92-301-127	-	-	Line Mounted - two 5/8" tubes, 5 1/2" Long X 3 1/4" Dia.
RA101-524009-0163	-	-	-	-	101-524009-0163	-	-	Beechcraft King Air series
-	-	-	-	-	101-524009-0161	-	-	Rudder boost filter with drain hole
-	-	-	-	-	101-524009-91	-	-	Line Mounted - two 5/8" tubes, 5 1/2" Long X 3 1/4" Dia.

For reference only.

51419

**Fittings**

RAPCO		Airborne		Aero Acc. / Tempest PN.	Piper PN.	Description	
PN.		Latest PN.	Superseded				
RA1K1-6-10	-	1K1-6-10	-	AA1K1-6-10	-	458 958	Dry Air Pump Fitting - 90 Degree, 3/8" NPT, 5/8" Hose
RA1K8-6-10	-	1K8-6-10	-	AA1K8-6-10	-	560 810	Dry Air Pump Fitting - 152 Degree, 3/8" NPT, 5/8" Hose
RA1K10-6-10	-	1K10-6-10	-	AA1K10-6-10	-	-	Dry Air Pump Fitting - Straight, 3/8" NPT, 5/8" Hose
RA1K1-4-6	-	1K1-4-6	134A3	AA1K1-4-6	-	458 945	Instrument Fitting - 90 Degree, 1/4" NPT, 3/8" Hose
RA1K10-4-6	-	1K10-4-6	-	AA1K10-4-6	-	451 939	Instrument Fitting - Straight, 1/4" NPT, 3/8" Hose
RA1K31-4-6-4	-	1K31-4-6-4	-	AA1K31-4-6-4	-	560 835	Instrument Fitting - T, 1/4" NPT, 3/8" & 1/4" Hose

For reference only.

51419

**Manifold Check Valves**

RAPCO PN.	Airborne PN.	Piper PN.	Description
<b>Vacuum</b>			
RA1H5-1	1H5-1	-	Hose Fittings - Two 5/8"Pump, Two 3/8"Inst. Two 1/4" Ga.

For reference only.

51419

**Regulators**

RAPCO		Airborne		Aero Acc. / Tempest PN.	Piper PN.	Description	
PN.		Latest PN.	Superseded				
<b>Vacuum</b>							
RA2H3-2	-	2H3-2	133A3	AA2H3-2	-	C482001-0101	5/8" Hose (Pump), 1/2" Hose (Instrument)
RA2H3-5	-	2H3-5	133C1	AA2H3-5	-	-	5/8" Hose (Pump), 5/8" Hose (Instrument)
RA2H3-6	-	2H3-6	133B3	AA2H3-6	-	584 324	5/8" Hose (Pump), 5/8" Hose (Instrument)
RA2H3-11	-	2H3-11	133A13	-	-	-	Two AN-10A Flaired Tube Fittings
RA2H3-12	-	2H3-12	2H3-16, 133A16	AA2H3-12	-	C482001-0401	5/8" Hose (Pump), two 3/8" Hose (Instrument)
RA2H3-15	-	2H3-15	-	-	-	-	One AN-10A Flaired Tube Fitting
RA2H3-19	-	2H3-19	-	-	-	492 240	5/8" Hose (Pump), two 3/8" Hose (Inst.) w/ vac switch
RA2H3-23	-	2H3-23	133A4	AA2H3-23	-	49 -056	5/8" Hose (Pump), two 3/8" Hose (Instrument)
-	-	-	-	-	-	492 272	-
RA2H3-48	-	2H3-48	-	AA2H3-23	-	-	AN-10A Flaired Tube Fitting (Inst.), 5/8" Hose (Pump)

For reference only.

10919

All Airborne pumps available FAA Approved overhauled. For installation eligibility refer to FAA-PMA Supplement.

For reference only.



**RAPCO PNEUMATICS CROSS REFERENCE GUIDE**

*New - Dry Air Pumps, Filters, Fittings, Manifold Check Valves and Regulators, FAA-PMA Approved*

*Overhauled - Dry Air Pumps with FAA / EASA / CAA Approved Data with Dual Release FAA form 8130-3*

**211CC, 211CC-9, 212CW, 212CW-6 Dry Air Pumps are OEM pumps overhauled by RAPCO Inc.**

**Dry Air Pumps**

RAPCO			Airborne		Aero Acc. / Tempest PN.	Beech PN.	Cessna PN.	Piper PN.	Description
New PN.	Overhaul PN.	Superseded	Latest PN.	Superseded					
RAP215CC	RAP215CC-OH - 211CC - - - - - - - - - - -	- RA215CC 215CC - - - - - - - - - -	- 215CC - - - - - - - - - - -	- - 211CC - 200CC - 201CC 203CC 201CC 201CC	AA3225CC AA3215CC AA215CC AA211CC	- - 92-410-911 - 92-410-795 - - - -	- - J470280C C431003-0101 C431002-0102 C431002-0101 C431002-0102 C431002-0102 - - - - - -	- - 481 764 PLH 481 753 VRB - 481 602 - 481 738 - - 481 738 481 738	Ports - 3/8" NPT
RAP215CC-9	RAP215CC-9-OH - 211CC-9 - - - - - - - -	- RA215CC-9 215CC-9 - - - - - - - -	- 215CC-9 - - - - - - - - -	- - 211CC-9 200CC-9	AA3225CC-9 AA3215CC-9 AA215CC-9 AA211CC-9	- - - - - - - -	- - C431003-0103 C431002-0102	- - - - - - - -	Ports - 3/8" NPT, Vertical mounting option
RAP216CW	RAP216CW-OH - 212CW - - - - - - -	- RA216CW 216CW - - - - - - -	- 216CW - - - - - - - -	- - 212CW - 200CW 204CW	AA3226CW AA3216CW AA216CW AA212CW	- - 92-410-908 - - - -	- - J470281 C431003-0102 C431002-0103 C431004-0202	- - 481 765 PLH 481 754 VRB 481 732 -	Ports - 3/8" NPT
	212CW-6	-	212CW-6	-	-	-	-	-	Ports - 3/8" NPT, Pulley drive shaft
RAP241CC	RAP241CC-OH - - -	RA441CC 241CC - -	241CC - - -	- - 231CC	AA243CC AA241CC	- - 92-428-126	- - C431004-0201	- - -	Ports - 3/8" NPT
RAP241CC-13	RAP241CC-13-OH - -	RA241CC-13 241CC-13 -	241CC-13 -	- -	AA243CC-13 AA241CC-13	- -	- -	- -	Ports - 3/8" NPT
RAP241CC-15	RAP241CC-15-OH - -	RA241CC-15 241CC-15 -	241CC-15 -	- -	AA243CC-15 AA241CC-15	- -	- -	- -	Ports - 3/8" NPT
RAP242CW	RAP242CW-OH - -	RA242CW 242CW -	242CW -	- 232CW	AA244CW	92-414-844 92-411-500	- -	- -	Ports - 3/8" NPT
RAP242CW-4	RAP242CW-4-OH - -	RA242CW-4 242CW-4 -	242CW-4 -	- -	AA244CW-4 AA242CW-4	92-414-845	- -	- -	Ports - 3/8" NPT
RAP242CW-10	RAP242CW-10-OH - -	RA242CW-10 242CW-10 -	242CW-10 -	- -	AA244CW-10 AA242CW-10	- -	- -	- -	Ports - 3/8" NPT
RAP441CC	RAP441CC-OH - -	RA441CC 441CC -	441CC -	- 431CC	AA441CC	92-428-126	C431004-0101 J470200 C431004-0101	- - -	Ports - 1/2"NPT
RAP441CC-3	RAP441CC-3 -	RA441CC-3 441CC-3 -	441CC-3 -	- -	AA441CC-3	- -	- -	- -	Ports - 1/2"NPT
RAP441CC-7	RAP441CC-7-OH - -	RA441CC-7 441CC-7 -	441CC-7 -	- 431CC-7	AA441CC-7	- -	- -	481 769 481 777 481 720	Ports - 1/2"NPT
RAP441CC-9	RAP441CC-9-OH - -	RA441CC-9 441CC-9-OH -	441CC-9 -	- 431CC-9	AA441CC-9	92-428-131 92-428-121	- -	- -	Ports - 1/2"NPT
RAP441CC-17	RAP441CC-17-OH - -	RA441CC-17 441CC-17-OH -	441CC-17 -	- -	- -	- -	- -	481 811	Ports - 1/2"NPT
RAP441CC-23	RAP441CC-23-OH - -	RA441CC-23 441CC-23 -	441CC-23 -	- -	- -	- -	- -	- -	Ports - 1/2"NPT
RAP442CW	RAP442CW-OH - -	RA442CW 442CW -	442CW -	- 432CW	AA442CW	92-428-127 92-428-122	J470177 -	- -	Ports - 1/2"NPT
RAP442CW-4	RAP442CW-4-OH - -	RA442CW-4 442CW-4 -	442CW-4 -	- -	AA442CW-4	92-428-129	- -	- -	Ports - 1/2"NPT
RAP442CW-6	RAP442CW-6-OH - -	RA442CW-6 442CW-6 -	442CW-6 -	432CW-6 432CW-6	AA442CW-6	- -	- -	481 770 481 778 481 742	Ports - 1/2"NPT
RAP442CW-8	RAP442CW-8-OH - -	RA442CW-8 442CW-8 -	442CW-8 -	- 432CW-8	AA442CW-8	- -	C431004-0102 C431004-0102	- -	Ports - 1/2"NPT
RAP442CW-12	RAP442CW-12-OH - -	RA442CW-12 442CW-12 -	442CW-12 -	- 432CW-12	AA442CW-12	92-428-128 92-428-123	- -	- -	Ports - Inlet - 1/2"NPT, Outlet - Flange for 1K 24-2 fitting (3/4" hose).
RAP442CW-14	RAP442CW-14-OH - -	RA442CW-14 442CW-14 -	442CW-14 -	- -	AA442CW-14	92-428-132	- -	- -	Ports - 1/2"NPT
RAP442CW-20	RAP442CW-20-OH - -	RA442CW-20 442CW-20 -	442CW-20 -	- -	AA442CW-20	- -	- -	481 841	Ports - 1/2"NPT

For reference only.

11424

**MISCELLANEOUS DRY AIR PUMP REPLACEMENT INFORMATION**

Bi-Directional Pumps	
Sigma Tec 1U128, 1U28A, B	Replace with RAP215CC or RAP216CW depending on rotation. Check IPC and eligibility to find the proper pump for your aircraft and engine. CC refers to Counter Clockwise rotation, or CW refers to Clockwise rotation as viewed from the pilot seat, or looking at the back of the pump.
Wet Pumps	
Airwolf 39194-AFC, Garwin G455, Pescó 3P194,	Wet pumps can be replaced by dry air pumps on aircraft that are approved to do so. Check approval data and eligibility to find the correct dry air pump for your aircraft. Proper pump rotation for your particular engine is critical. CC refers to Counter Clockwise rotation, or CW refers to Clockwise rotation, as viewed from the pilot seat or looking at the back of the pump.

For reference only.

120721

# Dry Air Pump Rear End Identifiers

(Not to scale)

For Reference Only

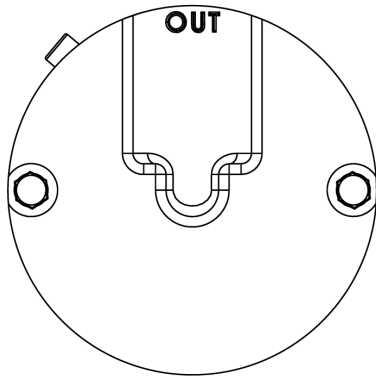

RAP215CC, 211CC, 215CC  
RAP215CC-9 & 215CC-9

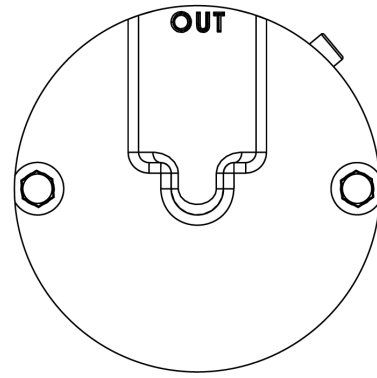

RAP216CW, 212CW & 216CW

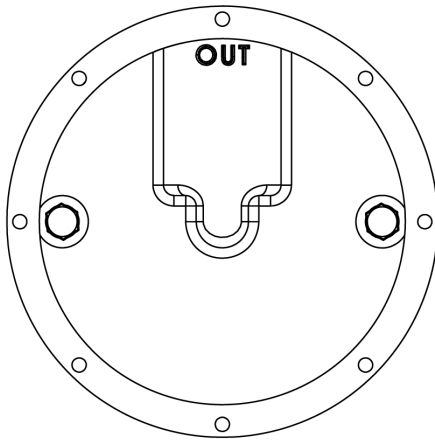

RAP241CC & 241CC

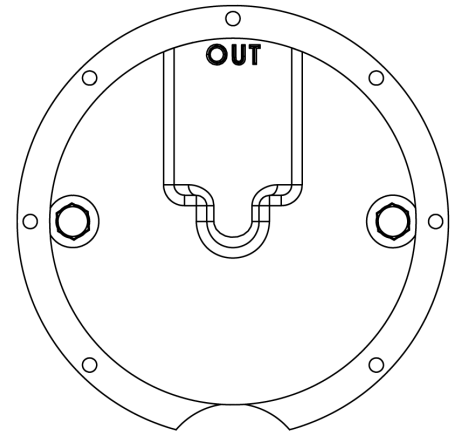

RAP241CC-13 & 241CC-13

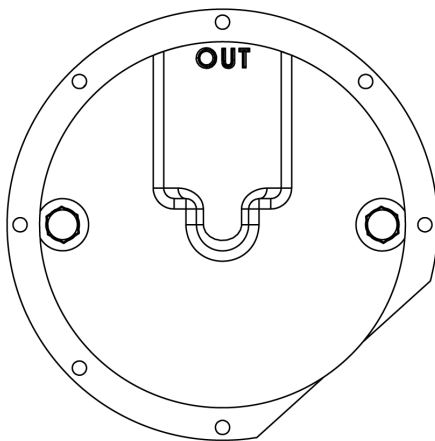

RAP241CC-15 & 241CC-15

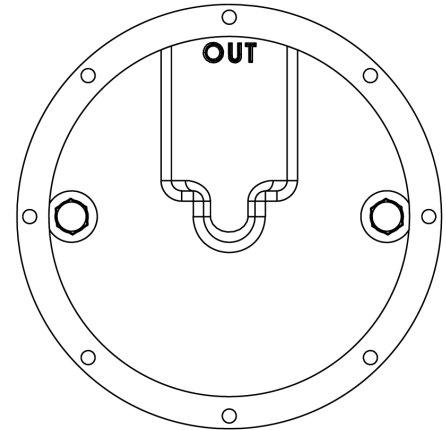

RAP242CW & 242CW

# Dry Air Pump Rear End Identifiers

(Not to scale)

For Reference Only

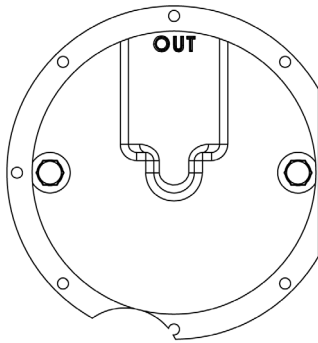

RAP242CW-4 & 242CW-4

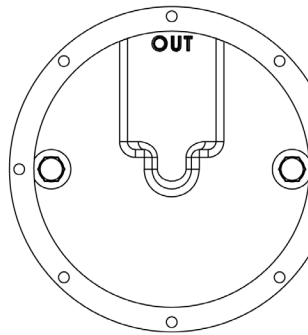

RAP242CW-10 & 242CW-10

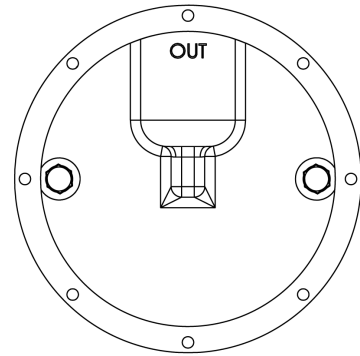

RAP441CC & 441CC

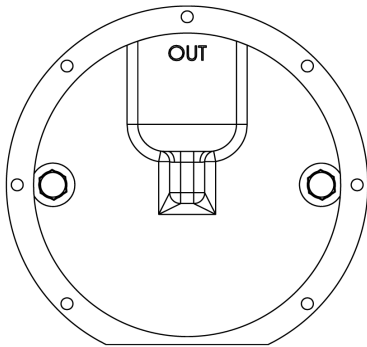

RAP441CC-3 & 441CC-3

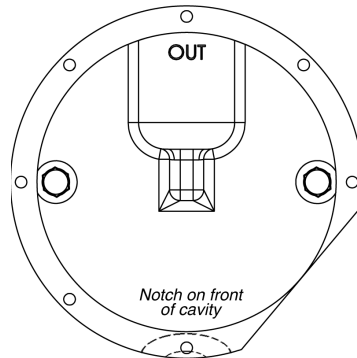

RAP441CC-7 & 441CC-7

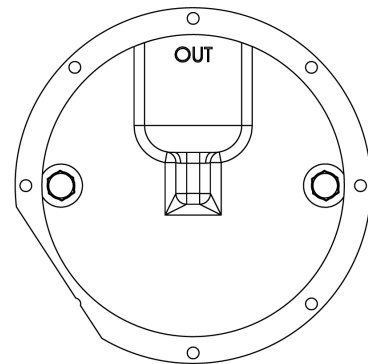

RAP441CC-9 & 441CC-9

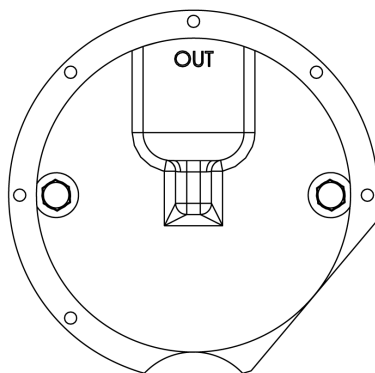

RAP441CC-17 & 441CC-17

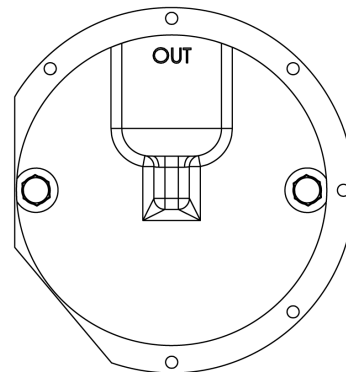

RAP441CC-23 & 441CC-23

# Dry Air Pump Rear End Identifiers

(Not to scale)

For Reference Only

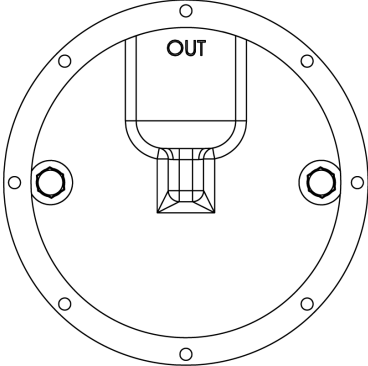

RAP442CW & 442CW

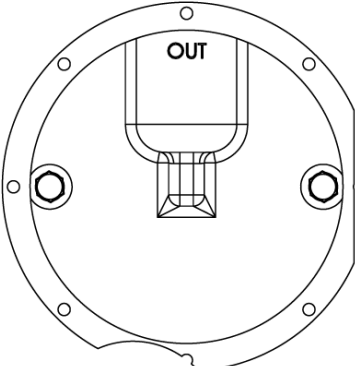

RAP442CW-4 & 442CW-4

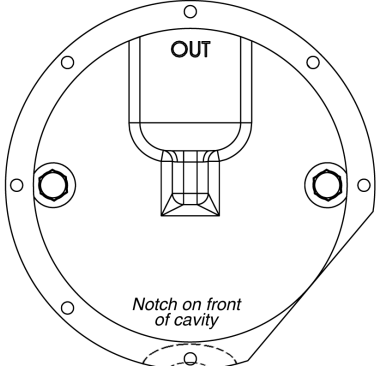

RAP442CW-6 & 442CW-6

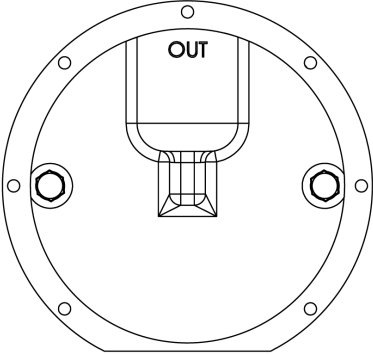

RAP442CW-8 & 442CW-8

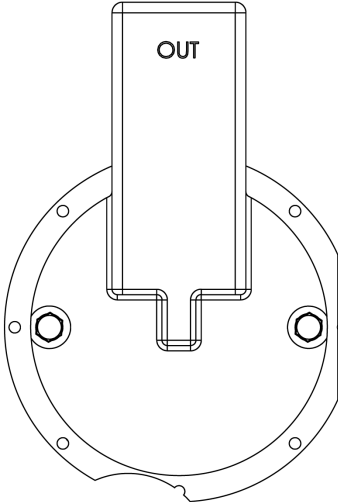

RAP442CW-12 & 442CW-12

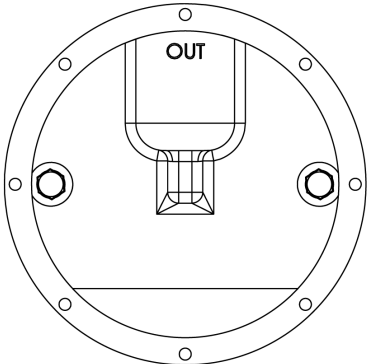

RAP442CW-14 & 442CW-14

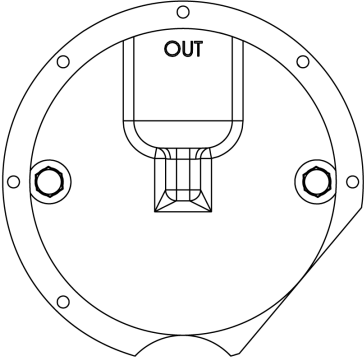

RAP442CW20 & 442CW-20

# NEW FAA PMA Approved Pneumatic Regulators



**RA2H3-2:** 5/8" Hose (Pump), 1/2" Hose (Instrument)



**RA2H3-5:** 5/8" Hose (Pump), 5/8" Hose (Instrument)



**RA2H3-6:** 5/8" Hose (Pump), 5/8" Hose (Instrument)



**RA2H3-11 :** Two AN-10A Fittings



**RA2H3-12 :** 5/8" Hose (Pump), two 3/8" Hose (Instrument)



**RA2H3-15 :** One AN-10A Fittings



**RA2H3-19 :** 5/8" Hose (Pump), two 3/8" Hose (Inst.) w/ Vac Switch



**RA2H3-23 :** 5/8" Hose (Pump), two 3/8" Hose (Instrument)



**RA2H3-48 :** AN-10A Fitting (Pump), 5/8" Hose (Inst.)

***RAPCO, inc.***

**REPLACEMENT AIRCRAFT PARTS CO.**

445 Cardinal Lane

Hartland, Wisconsin 53029 USA

For a list of Distributors, please call.

(262) 367-2292 Phone (262) 367-7158 Fax

[www.rapcoinc.com](http://www.rapcoinc.com)



For Reference Only



# Why choose a Rapco Pump?

- A.** Inspection port allowing for on-aircraft measurement
  - B.** Chamfered rotor allowing for small foreign objects to pass
  - C.** Oil seal to help prevent fluid contamination
  - D.** Mil-Spec coated cavity to reduce friction
- .... and of course it saves you and your customers money

**1-800-527-2726**  
[www.rapcoinc.com](http://www.rapcoinc.com)

**RAPCO**,inc.  
REPLACEMENT AIRCRAFT PARTS CO.

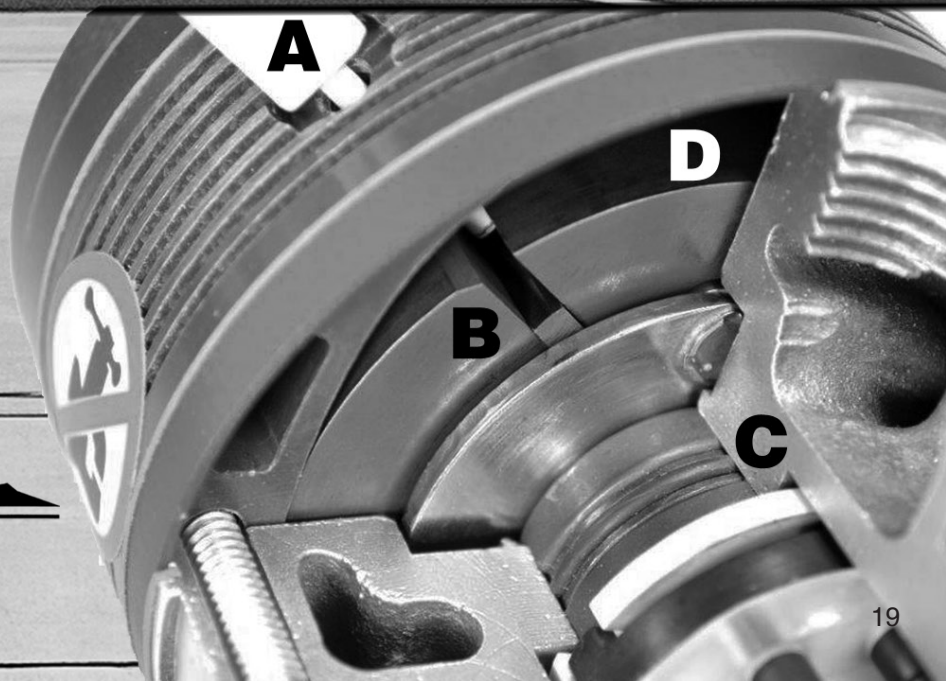

# Pneumatic Fittings

## FAA PMA Approved For Aircraft Pneumatic Instrument Systems

- Smooth curve design minimizes loss of vacuum or pressure over standard AN or MS fittings.
- Wide unrestricted passages help maintain flow rate at altitude.
- Less restriction on the pneumatic system which increases dry air pump service life.



**RA1K1-6-10 Fitting, 90 degree, 3/8" NPT, 5/8" hose**  
Fits 200 thru 242 series dry air pump inlet ports.  
Replaces - Airborne PN. 1K1-6-10



**RA1K8-6-10 Fitting, 152 degree, 3/8" NPT, 5/8" hose**  
Fits 200 thru 242 series dry air pump outlet ports.  
Replaces - Airborne PN. 1K8-6-10



**RA1K10-6-10 Fitting, straight, 3/8" NPT, 5/8" hose**  
Fits 200 thru 242 series dry air pumps.  
Replaces - Airborne PN. 1K10-6-10



**RA1K1-4-6 Fitting, 90 Degree, 1/4" NPT, 3/8" hose**  
For instrument inlet and outlet ports.  
Replaces - Airborne PN. 1K1-4-6



**RA1K10-4-6 Fitting, straight, 1/4" NPT, 3/8" hose**  
For instrument inlet and outlet ports.  
Replaces - Airborne PN. 1K10-4-6



**RA1K31-4-6-4 Fitting, T, 1/4" NPT, 3/8" hose, 1/4" hose T**  
For instrument inlet and outlet ports with T for gauge.  
Replaces - Airborne PN. 1K31-4-6-4

**RAPCO, inc.**

**REPLACEMENT AIRCRAFT PARTS CO.**

445 Cardinal Lane

Hartland, Wisconsin 53029 USA

For a list of Distributors, please click on the document on the home screen or visit [www.rapcoinc.com](http://www.rapcoinc.com)



For Reference Only

# Pump Wrench

**TOOL FOR THE REMOVAL AND INSTALLATION OF DRY AIR VACUUM PUMPS**

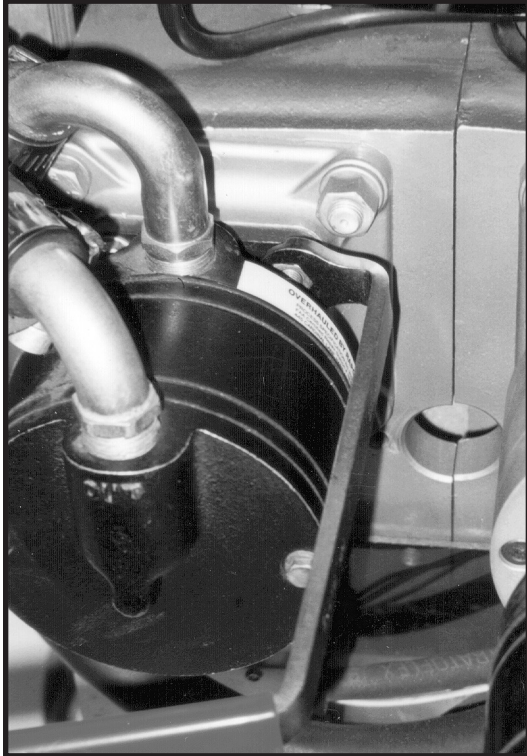

- \* **Provides superior access to vacuum pump flange nuts.**
- \* **Quality hardened steel with corrosion resistant nickel plating.**
- \* **Shaped to provide easy access to tight areas between the pump and accessories.**
- \* **Plastic coated handle provides a firm grip.**

***RAPCO,inc.***

**REPLACEMENT AIRCRAFT PARTS CO.**

445 Cardinal Lane

Hartland, Wisconsin 53029 USA

For a list of Distributors, please click on the document on the home screen or visit [www.rapcoinc.com](http://www.rapcoinc.com)



# Replacement De-Ice Application Guide

## FAA-PMA Approved Wire Harness, and Brush Replacement Parts for BFG and McCauley Propeller De-Ice Systems



For reference only. For installation eligibility refer to the FAA-PMA Supplement.

Some aircraft models or particular serial numbers may have applications other than those listed in this guide. Consult the appropriate aircraft parts catalogue, maintenance manual or equipment list when selecting a part for installation. To convert a BFG part number to a RAPCO part number replace the 2E, 3E or 4E with RA and add 100 to the number. To convert a McCauley part number to a RAPCO simply add RA to the beginning of the part number.

***RAPCO,inc.***

**REPLACEMENT AIRCRAFT PARTS CO.**

445 Cardinal Lane

Hartland, Wisconsin 53029 USA

For a list of Distributors, please click on the document on the home screen or visit [www.rapcoinc.com](http://www.rapcoinc.com)





## RAPCO INC. FAA Approved Replacement Parts for BFG and McCauley Propeller De-Ice Systems

Propeller De-ice: Brushes, Wire Harnesses, Clamps, Spacers, and Wear Strips

This Application Guide is to be used for reference only.

When selecting a part for installation consult the aircraft manufacturer's approved parts catalogue.

To convert a BFG part number to a RAPCO FAA-PMA approved part number replace the 2E, 3E or 4E with RA and add 100 to the number.

To convert a McCauley part number to a RAPCO FAA-PMA approved part number add RA to the beginning of the number.

In the case of a particular application showing an STC, the aircraft must first have the STC installed before a replacement part can be installed.

In some cases a brush may be approved as part of an assembly. [Refer to the FAA-PMA Supplement for installation eligibility.](#)

Blue - BFG De-ice Equiped							
Green - McCauley De-ice Equiped							
Aircraft Manufacturer and Model # Notes	Propeller Model #	De-Icer OEM PN	Wire Harness PN / Hub Extender PN	Solid Block OEM PN	Modular Brush Block Assy. PN	Brush Module PN (Quantity)	Brush PN (Quantity)
<b>Aero Commander / Rockwell / Gulfstream / Twin Commander</b>							
500 Series with Colemill STC SA340SO with Continental Engines	HC-A2XF-2B			4E1387-3			RA1543-1 (2) & RA1543-2 (1)
					RA2142-1	RA2111U-ROD (3)	RA1543-7 (3)
500A with Goodrich STC SA1-607 with Lycoming Engines	HC-A2XF-2			4E1350_-1			RA1306-1 (3)
				4E1350-4			RA1543-2 (3)
					RA2146-2	RA2111U-ROD (3)	RA1543-7 (3)
500A with Goodrich STC SA132EA with Lycoming Engines	HC-A3X20-2			4E1311_-1			RA1306-1 (2) & RA1306-2 (1)
				4E1311-2			RA1543-1 (2) & RA1543-2 (1)
					RA2144-1	RA2111U-ROD (3)	RA1543-7 (3)
500B, 500S, 500U, with Lycoming Engines	HC-A3X/VK-2	4E1601-7	RA2067-2	4E1350_-1			RA1306-1 (3)
				4E1350-4			RA1543-2 (3)
					RA2146-2	RA2111U-ROD (3)	RA1543-7 (3)
500B, 500U with Goodrich STC SA1-606 with Lycoming Engines	HC-A3XK/VK-2				RA2146-2	RA2111U-ROD (3)	RA1543-7 (3)
					RA2146-2	RA2111U-ROD (3)	RA1543-7 (3)
560A, 560E, with Goodrich STC SA132EA with Lycoming Engines	HC-A3X20-2			4E1311_-1			RA1306-1 (2) & RA1306-2 (1)
					RA2144-1	RA2111U-ROD (3)	RA1543-7 (3)
560A, 560E, with Goodrich STC SA1-520 Lycoming Engines	H83x20			4E1311_-1			RA1306-1 (2) & RA1306-2 (1)
				4E1311-2			RA1543-1 (2) & RA1543-2 (1)
					RA2144-1	RA2111U-ROD (3)	RA1543-7 (3)
560F with Goodrich STC SA179EA with Lycoming Engines	HC-B3Z30-2B	4E2200-10	RA2192-2	4E1387-1			RA1306-1 (2) & RA1306-2 (1)
				4E1387-5			RA1543-1 (2) & RA1543-2 (1)
					RA2142-1	RA2111U-ROD (3)	RA1543-7 (3)
680, 680E with Goodrich STC SA132EA with Lycoming Engines	HC-A3X20-2			4E1311_-1			RA1306-1 (2) & RA1306-2 (1)
					RA2144-1	RA2111U-ROD (3)	RA1543-7 (3)
680, 680E, 720 with Goodrich STC SA1-520 with Lycoming Engines	H83x20			4E1311_-1			RA1306-1 (2) & RA1306-2 (1)
				4E1311-2			RA1543-1 (2) & RA1543-2 (1)
					RA2144-1	RA2111U-ROD (3)	RA1543-7 (3)
680F, 680FL, 680FP, 680FLP with Goodrich STC SA179EA with Lycoming Engines	HC-B3Z30-2B	4E2200-10	RA2192-2	4E1387-1			RA1306-1 (2) & RA1306-2 (1)
				4E1387-5			RA1543-1 (2) & RA1543-2 (1)
					RA2142-1	RA2111U-ROD (3)	RA1543-7 (3)
680F, 680FL, 680FL(P) with MR RPM STC's SA2891WE or SA2691WE with Lycoming Engines	HC-A3MVK-2A	4E2200-10	RA2192-2	4E1350-1,-2,-3			RA1306-1 (2) & RA1306-2 (1)
				4E1350-4,-5,-6			RA1543-1 (2) & RA1543-2 (1)
					RA2146-1	RA2111U-ROD (3)	RA1543-7 (3)
680T, 680V, 680W, with AiResearch Engines	33LF-325			4E1387-1			RA1306-1 (2) & RA1306-2 (1)
				4E1387-5			RA1543-1 (2) & RA1543-2 (1)
					RA2142-1	RA2111U-ROD (3)	RA1543-7 (3)
680W Pacific Propeller STCs SA924NW, SA1184NW with Lycoming Engines	HC-B3TN-5K			4E1387-1			RA1306-1 (2) & RA1306-2 (1)
				4E1387-5			RA1543-1 (2) & RA1543-2 (1)
					RA2142-1	RA2111U-ROD (3)	RA1543-7 (3)



Aircraft Manufacturer and Model # Notes	Propeller Model #	De-Icer OEM PN	Wire Harness PN / Hub Extender PN	Solid Block OEM PN	Modular Brush Block Assy. PN	Brush Module PN (Quantity)	Brush PN (Quantity)
685 with Continental Engines	HC-F3YN-2 HC-H3YN-2			4E1387-5			RA1543-1 (2) & RA1543-2 (1)
					RA2142-1	RA2111U-ROD (3)	RA1543-7 (3)
681 with AiResearch Engines	33LF-325			4E1387-1			RA1306-1 (2) & RA1306-2 (1)
				4E1387-5			RA1543-1 (2) & RA1543-2 (1)
					RA2142-1	RA2111U-ROD (3)	RA1543-7 (3)
690, 690A, 690B with AiResearch Engines	HC-B3TN-5FL	4E1601-5	RA1989-2	4E1387-5			RA1543-1 (2) & RA1543-2 (1)
					RA2142-1, -2	RA2111U-ROD (3)	RA1543-7 (3)
690C, 690D 695, 695A with AiResearch Engines	Dowty Roto1 324				RA2142-1	RA2111U-ROD (3)	RA1543-7 (3)
700 Fuji 300-12 with Lycoming Engines	HC-E3YR-2AF	4E1601-7	RA2067-1	4E1639			RA1543-1 (2) & RA1543-2 (1)
					RA2142-2	RA2111U-ROD (3)	RA1543-7 (3)
720 with Goodrich STC SA132EA with Lycoming Engines	HC-A3X20-2			4E1311, -1			RA1306-1 (2) & RA1306-2 (1)
					RA2144-1	RA2111U-ROD (3)	RA1543-7 (3)
720 with Goodrich STC SA1-520 with Lycoming Engines	H83x20			4E1311, -1			RA1306-1 (2) & RA1306-2 (1)
				4E1311-2			RA1543-1 (2) & RA1543-2 (1)
					RA2144-1	RA2111U-ROD (3)	RA1543-7 (3)
<b>Aero Vodochody</b>							
AE270 with Pratt & Whitney Engine	HC-E4N-3P				RA2142-2	RA2111U-ROD (3)	RA1543-7 (3)
<b>Aerostar / Ted Smith Aerostar / Piper Aerostar</b>							
PA-60-600, PA-60-601, PA-60-601P, PA-60-602P with Lycoming Engines	HC-C3YR-2			4E1350-2			RA1306-1 (3)
				4E1350-5			RA1543-2 (3)
PA-60-700P with Lycoming Engines	HC-C3YR-2/2L	4E2271-10 4E22-10	RA2150-2 RA2150-2		RA2171	RA2111U-ROD (2)	RA1543-7 (2)
<b>Aerospatiale</b>							
Nord 262A			RA2192-4				
<b>American Jet Industries</b>							
Hustler with AiResearch Engine	HC-B4TN-5F				RA2142-1	RA2111U-ROD (3)	RA1543-7 (3)
<b>Antonov</b>							
AN-28 with Pratt & Whitney Engines	BHC-C2YF				RA2190-1	RA2111U-ROD (3)	RA1543-7 (3)
<b>Avia Acord</b>							
Avia Acord with Continental Engines	BHC-C2YF-2KUF	4E2271-10	RA2192-2		RA2190-1	RA2111U-ROD (3)	RA1543-7 (3)
Avia Acord 201 with Continental Engines	BHC-C3YF-2KUF	4E1601-10	RA2067-3		RA2142-1	RA2111U-ROD (3)	RA1543-7 (3)
<b>Beech / Beechcraft / Raytheon / Hawker Beechcraft / Textron</b>							
Beech 18 with American Turbine Westwind STC with Pratt & Whitney Engines	HC-B3TN-3			4E1311-1			RA1306-1 (2) & RA1306-2 (1)
				4E1311-2			RA1543-1 (2) & RA1543-2 (1)
					RA2144-1	RA2111U-ROD (3)	RA1543-7 (3)
Beech 18 with Goodrich STC SA1-502 with Pratt & Whitney Engines	HC-B3TN-3			4E1311-1			RA1306-1 (2) & RA1306-2 (1)
				4E1311-2			RA1543-1 (2) & RA1543-2 (1)
					RA2144-1	RA2111U-ROD (3)	RA1543-7 (3)
33 Bonanza with 14 Volt System with Continental Engine	2A36C23/C82 3A32C76			4E1387-3, -5			RA1543-1 (2) & RA1543-2 (1)
F33A, F33C with Machen STC SA762NW, 28 Volt with Continental Engine	HC-F3YR-1RF				RA2142-1 RA2171	RA2111U-ROD (3) RA2111U-ROD (2)	RA1543-7 (3) RA1543-7 (2)

For Reference ONLY. For installation eligibility see FAA-PMA supplement.



Aircraft Manufacturer and Model # Notes	Propeller Model #	De-Icer OEM PN	Wire Harness PN / Hub Extender PN	Solid Block OEM PN	Modular Brush Block Assy. PN	Brush Module PN (Quantity)	Brush PN (Quantity)
F33A with McCauley De-ice with Continental IO-520-BB, -UB, -B Engine	3A32C406/82NDB-X, D3A32C409/82NDB-X			C-40151 C-40257 Assy.			RAC40256-1 (1) & RAC40256-2 (1)
35-C33A Bonanza with Continental Engine	3A32C76 (McCauley) (Hartzell) PHC-C3YF-1RF				RA2162-2	RA2111U-ROD (2)	RA1543-7 (2)
F33A Bonanza with Continental Engine	3A32C76 (McCauley) PHC-C3YF-1RF (Hartzell)				RA2162-2	RA2111U-ROD (2)	RA1543-7 (2)
35 Bonanza with 14 Volt. with Continental Engine	2A36C23/C82 3A32C76			4E1387-3, -5			RA1543-1 (2) & RA1543-2 (1)
A35B Bonanza with Continental Engine	3A32C76 (McCauley) PHC-C3YF-1RF (Hartzell)				RA2142-1	RA2111U-ROD (3)	RA1543-7 (3)
S-35 Bonanza with Continental Engine	3A32C76 (McCauley) PHC-C3YF-1RF (Hartzell)				RA2162-2	RA2111U-ROD (2)	RA1543-7 (2)
S-35	PHC-A3VF-4			4E1387-3, -5			RA1543-1 (2) & RA1543-2 (1)
S-35 with Machen STC SA762NW, 28 Volt with Continental Engine	HC-F3YR-1RF				RA2142-1	RA2111U-ROD (3)	RA1543-7 (3)
V-35 Bonanza with Continental Engine	3A32C76 (McCauley) PHC-C3YF-1RF (Hartzell)				RA2171	RA2111U-ROD (2)	RA1543-7 (2)
V-35 with Continental Engine	PHC-A3VF-4			4E1387-3, -5			RA1543-1 (2) & RA1543-2 (1)
V35 with 14 Volt. with Continental Engine	2A36C82/C23 2A37C223				RA2142-1	RA2111U-ROD (3)	RA1543-7 (3)
V35A, V35B with Machen STC SA762NW, 28 Volt with Continental Engine	HC-F3YR-1RF				RA2162-2	RA2111U-ROD (2)	RA1543-7 (2)
V35B with McCauley De-ice with Continental IO-520-BB, -UB, -B Engine	3A32C406/82NDB-X, D3A32C409/82NDB-X			C-40151 C-40257 Assy.			RAC40256-1 (1) & RAC40256-2 (1)
36 Bonanza with 14 Volt. with Continental Engine	2A36C23/C82 3A32C76			4E1387-3, -5			RA1543-1 (2) & RA1543-2 (1)
36 Bonanza with Colemill STC SA1835SO with Continental Engine	HC-C4YF-1E				RA2142-1	RA2111U-ROD (3)	RA1543-7 (3)
36, A36 Bonanza with Machen STC SA762NW, 28 Volt with Continental Engine	HC-F3YR-1RF				RA2162-2	RA2111U-ROD (2)	RA1543-7 (2)
A36, A36TC Bonanza with Tradewind Turbine STC SA3523NM with Continental Engine	HC-B3TF-7A				RA2171	RA2111U-ROD (2)	RA1543-7 (2)
A36TC, A36, B36TC Bonanza with 28 Volt. with Continental Engine	3A32C76 (McCauley) PHC-C3YF-1RF (Hartzell)				RA2162-2	RA2111U-ROD (2)	RA1543-7 (2)
A36, B36TC with Hartzell STC SA00719LA with Continental Engine	PHC-3CYF-1RF				RA2162-2	RA2111U-ROD (2)	RA1543-7 (2)
A36, B36TC, with Hartzell STC SA00719LA with McCauley De-ice with Continental IO-520-BB, -UB, -B Engine	3A32C406/82NDB-X, D3A32C409/82NDB-X			C-40151 C-40257 Assy.			RAC40256-1 (1) & RAC40256-2 (1)
E50, F50, G50, H50, Twin Bonanza with Goodrich STC SA1-503 with Lycoming Engines	HC-B3T/B3Z			4E-1311-2			RA1543-1 (2) & RA1543-2 (1)
E50, F50, J50, Twin Bonanza with Goodrich STC SA15EA with Lycoming Engines	HC-B3T/B3Z			4E1311			RA1543-7 (3)
B55, E55 Baron with Continental Engine	BHC-C2YF-2C			4E-1311-2			RA1306-1 (2) & RA1306-2 (1)
B55, E55 with Continental Engine	PHC-C3YR-2	4E2271-10	RA2194-2	4E1387-5			RA1543-1 (2) & RA1543-2 (1)
B55, E55 with Continental Engine	CHC-C2YF-2C	4E2271-10	RA2194-2	4E1387-5	RA2144-1	RA2111U-ROD (3)	RA1543-7 (3)
B55, E55 with Continental Engine	PHC-C3YF-2	4E1601-7 4E2271-10	RA2067-4 RA2194-1	4E1387-5	RA2142-1	RA2111U-ROD (3)	RA1543-1 (2) & RA1543-2 (1)
					RA2142-1	RA2111U-ROD (3)	RA1543-7 (3)

For Reference ONLY. For installation eligibility see FAA-PMA supplement.

Aircraft Manufacturer and Model # Notes	Propeller Model #	De-icer OEM PN	Wire Harness PN / Hub Extender PN	Solid Block OEM PN	Modular Brush Block Assy. PN	Brush Module PN (Quantity)	Brush PN (Quantity)
B55, E55 No Air Conditioning with Continental Engine	BHC-C2YF-2C	4E2271-10	RA2150-2		RA2162-2	RA2111U-ROD (2)	RA1543-7 (2)
B55, E55 No Air Conditioning with Continental Engine	PHC-C3YF	4E2271-10	RA2150		RA2162-2	RA2111U-ROD (2)	RA1543-7 (2)
C55 with Continental IO-470 Engine	2AF36C39/2AF34/C55				RA2142-2 (470)	RA2111U-ROD (3)	RA1543-7 (3)
C55 with Continental IO-520 Engine	2AF36C39/2AF34/C55				RA2142-1 (520)	RA2111U-ROD (3)	RA1543-7 (3)
C55, C55A, D55, D55A, E55, E55A with Beech STC for McCauley De-ice with Continental IO-550-C	3AF32C504/82NEA-X			C-40151 C-40593 Assy.			RAC40256-1 (1) & RAC40256-2 (1)
E55, E55A Baron with McCauley De-ice with Continental IO-520-C	3AF32C512/82NEA-X			C-40151 C-40257 Assy.			RAC40256-1 (1) & RAC40256-2 (1)
E55 Baron with Air Conditioning with Continental Engine	PHC-J3YF-2	4E2271-10	RA2150		RA2171	RA2111U-ROD (2)	RA1543-7 (2)
E55 Baron with Air Conditioning with Continental Engine	BHC-J3YF-2	4E2271-10	RA2150		RA2171	RA2111U-ROD (2)	RA1543-7 (2)
56TC Baron with Lycoming Engines	HC-F3YR-2	4E2271-10	RA2194-1 RA1656 Hub Ext.				
56TC Baron with Lycoming Engines	HC-F3YR-2	4E-1601-7 4E2271-10	RA2067-4 RA2194-1 RA1656 Hub Ext.				
58 Baron with Continental Engines	HC-J2YF-2C			4E1350-3			RA1306-2 (3)
58 Baron with Continental Engines	PHC-3YF-2			4E1350-5	RA2146-1	RA2111U-ROD (3)	RA1543-7 (3)
58 Baron with Continental Engines	BHC-J2YF-2C	4E2271-10	RA2150-2	4E1350-5	RA2146-1	RA2111U-ROD (3)	RA1543-2 (3) RA1543-7 (3)
58 Baron with Continental Engines	HC-J2YF-2C	4E1601-7, -10 4E2271-10	RA2067-3 RA2150-2	4E1350-5	RA2146-3	RA2111U-ROD (3)	RA1543-2 (3) RA1543-7 (3)
58 Baron with Continental Engines	PHC-J3YF-2	4E2271-10	RA2150		RA2171	RA2111U-ROD (2)	RA1543-7 (2)
58 Baron with Air Conditioning with Continental Engines	BHC-J3YF-2	4E2271-10	RA2150		RA2171	RA2111U-ROD (2)	RA1543-7 (2)
58 Baron with Hartzell STC SA5533NM with Continental Engines	PHC-J3YF-2UF	4E2271-13	3E2050		RA2171	RA2111U-ROD (2)	RA1543-7 (2)
58 Baron with Continental Engines	D3AF32C35			4E1350-5	RA2146-3	RA2111U-ROD (3)	RA1543-2 (3) RA1543-7 (3)
58, 58A Baron with McCauley De-ice with Continental IO-520-C	3AF32C512/82NEA-X			C-40151 C-40257 Assy.			RAC40256-1 (1) & RAC40256-2 (1)
58, 58A, 58P, 58PA, 58TC, 58TCA, with Beech STC for McCauley De-ice, 2 Brush with Continental IO-550-C, TSI0-550-L, -LB, -WB	3AF32C511/82NEA-X, 3AF32C512/82NEA-X			C-40151 C-40257 Assy.			RAC40256-1 (1) & RAC40256-2 (1)
58P, 58PA, 58TC, 58TCA with Beech STC for McCauley De-ice, 3 Brush with Thermoplastic Bolck with Continental IO-520-L, -LB, -WB	3AF32C521/82NLA-X			C-40189 C-40179 Assy.			RAB40189 (2)
56TC Baron with Lycoming Engines	HC-F3YR-2	4E2271-10	RA2194-1 RA1656 Hub Ext.				
60, Duke Series with Lycoming Engines	HC-F3YR-2	4E2271-10	RA2150 RA2067-4	4E1639			RA1543-1 (2) & RA1543-2 (1)
60 Duke with Lycoming Engines	HC-F3YR-2	4E-1601-7 4E2271-10	RA2067-4 RA2194-1 RA1656 Hub Ext.				
65 Queen Air with Goodrich STC SA1-503 with Lycoming Engines	HC-B3T/B3Z			4E-1311-2	RA2144-1	RA2111U-ROD (3)	RA1543-1 (2) & RA1543-2 (1) RA1543-7 (3)
65, Queen Air Excalibur STC SA444SW with Lycoming Engines	HC-A3VK-2A			4E1350-5	RA2146-1	RA2111U-ROD (3)	RA1543-2 (3) RA1543-7 (3)
J65, Queen Air with Goodrich STC SA15EA with Lycoming Engines	HC-B3T/B3Z	4E2200-3	On Boot	4E1311 4E-1311-2	RA2144-1	RA2111U-ROD (3)	RA1306-1 (2) & RA1306-2 (1) RA1543-1 (2) & RA1543-2 (1) RA1543-7 (3)



Aircraft Manufacturer and Model # Notes	Propeller Model #	De-Icer OEM PN	Wire Harness PN / Hub Extender PN	Solid Block OEM PN	Modular Brush Block Assy. PN	Brush Module PN (Quantity)	Brush PN (Quantity)
65-80, 65-A80-8800, Queen Air 65-88  with Goodrich STC SA15EA with Lycoming Engines	HC-B3T/B3Z	4E2200-3	On Boot	4E1311			RA1306-1 (2) & RA1306-2 (1)
				4E-1311-2			RA1543-1 (2) & RA1543-2 (1)
					RA2144-1	RA2111U-ROD (3)	RA1543-7 (3)
65, 65-80, 65-B80, Queen Air 65-88, A65, 65-A88-8800, 70 Excalibur STC SA444SW	HC-AVK-2A				RA2146-1	RA2111U-ROD (3)	RA1543-7 (3)
65-90 King Air with Non-Reversing Propellers with Pratt & Whitney Engines	HC-B3TN-2			4E1387, -1			RA1306-1 (2) & RA1306-2 (1)
				4E1387-5			RA1543-1 (2) & RA1543-2 (1)
					RA2142-1	RA2111U-ROD (3)	RA1543-7 (3)
65-90, with Pratt & Whitney Engines	HC-B3TN-3	4E2200-10	RA2192-2	4E1311, -1			RA1306-1 (2) & RA1306-2 (1)
				4E1311-2			RA1543-1 (2) & RA1543-2 (1)
					RA2144-1	RA2111U-ROD (3)	RA1543-7 (3)
65-90, with Pratt & Whitney Engines	HC-B3TN-3	4E2200-10	RA2192-2	4E-1311-2			RA1543-1 (2) & RA1543-2 (1)
65-A90 King Air with Raisbeck STC's SA3593NM, SA5661NM, SA2689NM with Pratt & Whitney Engines	HC-D4N-3A	4E2271-10	RA2192-4		RA2144-1	RA2111U-ROD (3)	RA1543-7 (3)
					RA2190-1	RA2111U-ROD (2)	RA1543-7 (2)
A90, A90-1, A90-4, B90, C90 (LJ-502 thru LJ-583) King Air with Beech STC with McCauley De-ice with Pratt & Whitney PT6A-20 Engines	4HFR34C762/94LMA-X	B-40245-52	RA40330	C-40151 C-40257 Assy.			RAC40256-1 (1) & RAC40256-2 (1)
B90, C90, King Air with Raisbeck STC's SA3593NM, SA5661NM, SA2689NM with Pratt & Whitney Engines	HC-D4N-3A	4E2271-10	RA2192-4		RA2190-1	RA2111U-ROD (2)	RA1543-7 (2)
C90A with Beech STC with McCauley De-ice with Pratt & Whitney PT6A-20A, -21, -28 Engine	4HFR34C768/94LMA-X	B-40245-52	RA40330	C-40151 C-40257 Assy.			RAC40256-1 (1) & RAC40256-2 (1)
C90A with McCauley De-ice with Pratt & Whitney PT6A-21 Engines	4HFR34C768/94LMA-X	B-40245-56	RA40585	C-40151 C-40257 Assy.			RAC40256-1 (1) & RAC40256-2 (1)
C90A with Hartzell STC SA00966CH with Pratt & Whitney Engines	HC-E4N-3N	4E2200-10	RA2192-4		RA2190-1	RA2111U-ROD (2)	RA1543-7 (2)
E90 with Raisbeck Quiet Propeller Conversion			RA2192-4				
F90 King Air with Pratt & Whitney Engines	HC-B4TN-3	4E2200-10	RA2192-3	4E1311-2			RA1543-1 (2) & RA1543-2 (1)
					RA2144-1	RA2111U-ROD (3)	RA1543-7 (3)
F90 with Raisbeck Quiet Propeller Conversion			RA2192-4				
95-C55, 95-C55A Continental Engines	3AF32C75			4E1387-1			RA1306-1 (2) & RA1306-2 (1)
				4E1387-5			RA1543-1 (2) & RA1543-2 (1)
					RA2142-1	RA2111U-ROD (3)	RA1543-7 (3)
95-55, -A55, -B55, -B55A, -B55B, with Beech STC for McCauley De-ice with Continental IO-470-L Engines	3AF32C504/82NEA-X			C-40151 C-40593 Assy.			RAC40256-1 (1) & RAC40256-2 (1)
99, Airliner with Pratt & Whitney Engines	HC-B3TN-3	4E2200-10	RA2192-2	4E1311, -1			RA1306-1 (2) & RA1306-2 (1)
				4E1311-2			RA1543-1 (2) & RA1543-2 (1)
					RA2144-1	RA2111U-ROD (3)	RA1543-7 (3)
99, 99A, A99, A99A, B99, C99 with Beech STC and McCauley De-ice with Pratt & Whitney PT6A-20, -27, -28, -36	4HFR34C769/94LMA-X 4HFR34C773/94LMA-X	B-40245-56	RA40585	C-40189 C-40179 Assy.			RAB40189
100, King Air with Pratt & Whitney Engines	HC-B3TN-3	4E2200-10	RA2192-2	4E1311, -1			RA1306-1 (2) & RA1306-2 (1)
				4E1311-2			RA1543-1 (2) & RA1543-2 (1)
					RA2144-1	RA2111U-ROD (3)	RA1543-7 (3)
100 King Air with Pratt & Whitney Engines 100, 200, King Air	HC-B3TN-3	4E2200-10	RA2192-2	4E-1311-2			RA1543-1 (2) & RA1543-2 (1)
					RA2144-1	RA2111U-ROD (3)	RA1543-7 (3)



Aircraft Manufacturer and Model # Notes	Propeller Model #	De-Icer OEM PN	Wire Harness PN / Hub Extender PN	Solid Block OEM PN	Modular Brush Block Assy. PN	Brush Module PN (Quantity)	Brush PN (Quantity)
100, A100 King Air with Raisbeck STC's SA3593NM, SA5661NM, SA2689NM with Pratt & Whitney Engines	HC-D4N-3A	4E2271-10	RA2192-4		RA2190-1	RA2111U-ROD (2)	RA1543-7 (2)
A100 with Pratt & Whitney Engines	HC-B4TN-3	4E2200-10	RA2192-3	4E1311-2			RA1543-1 (2) & RA1543-2 (1)
A100 King Air with Pratt & Whitney Engines	HC-B4TN-3	4E2200-10	RA2192-3		RA2144-1	RA2111U-ROD (3)	RA1543-7 (3)
100, A100, King Air with McCauley De-ice with Beech STC and McCauley De-ice with Pratt & Whitney PT6A-20, -34 Engines	4HFR34C762/94LMA-X	B-40245-52	RA40330	C-40151 C-40257 Assy.			RAC40256-1 (1) & RAC40256-2 (1)
A100-1 with McCauley De-ice with Beech STC and McCauley De-ice with Pratt & Whitney PT6A-41, -42 Engines	4HFR34C754/94LA-X	B-40245-52	RA40330	C-40151 C-40257 Assy.			RAC40256-1 (1) & RAC40256-2 (1)
B100 King Air with AirResearch Engines	HC-B4TN-5C/F	4E1188-5 4E2200-10	RA1989-2 RA2192-3	4E1387-5			RA1543-1 (2) & RA1543-2 (1)
B100, King Air with AirResearch Engines	HC-B4TN-5C/F	4E2200-10	RA2192-3		RA2142-1	RA2111U-ROD (3)	RA1543-7 (3)
B100 with Beech STC and McCauley De-ice with TPE331-6, -10 Engines	5HFR34C1105/96LRB-X	B-40245-52	RA40585	C-40411 C-40685 Assy.			RAC40464-1 (1) & RAC40464-2 (1)
200 King Air with Pratt & Whitney Engines	HC-B3TN-3	4E2200-10	RA2192-2	4E-1311-2			RA1543-1 (2) & RA1543-2 (1)
200 King Air with Raisbeck STC's SA3593NM, SA5661NM, SA2689NM with Pratt & Whitney Engines	HC-D4N-3A	4E2271-10	RA2192-4		RA2144-1	RA2111U-ROD (3)	RA1543-7 (3)
200, King Air with Pratt & Whitney Engines	HC-E4N-3G	4E2271-10	RA2192-4		RA2190-1	RA2111U-ROD (2)	RA1543-7 (2)
B200 with Raisbeck Quiet Propeller Conversion			RA2192-4				
A200C, 200C, B200 Series BB-1439, BB-1444 & after, except BB-1463, B200C, BL-139 & after and BW-1 & after			RA2192-4				
200, 200C, 200T, 200CT, A200C, A200CT, B200, B200C, B200T, B200CT, C-12D, C-12F, FWC-12D, RC-12D, UC-12B with Beech STC and McCauley De-ice with Pratt & Whitney PT6A-41, -42 Engines	5HFR34C1008/96LTA-0	B-40245-56	RA40585	C-40411 C-40685 Assy.			RAC40464-1 (1) & RAC40464-2 (1)
200, 200C, 200T, 200CT, A200C, A200CT, B200, B200C, B200CT, B200T, C-12D, C-12F, FWC-12D, RC-12D, UC-12B, U-21J with Beech STC and McCauley De-ice with Pratt & Whitney PT6A-41, -42 Engines	4HFR34C754/94LA-X	B-40245-52	RA40330	C-40151 C-40257 Assy.			RAC40256-1 (1) & RAC40256-2 (1)
A200CT (RC-12K, RC-12L, RC-12N, RC-12P, RC-12Q) with Beech STC and McCauley De-ice with Pratt & Whitney PT6A-67 Engines	4JFR34C758/106LNA-X			C-40411 C-40463 Assy.			RAC40464-1 (1) & RAC40464-2 (1)
B200, B200C (C-12F, UC-12M), B200CT, B200T with Beech STC and McCauley De-ice with Pratt & Whitney PT6A-42 Engines	3GFR34C702/100LA-X			C-40151 C-40257 Assy.			RAC40256-1 (1) & RAC40256-2 (1)
B200, B200C (C-12F, C-12R), B200CT, B200T with McCauley De-ice with Pratt & Whitney PT6A-42 Engines	4HFR34C771/94LA-X	B-40245-56	RA40585	C-40151 C-40257 Assy.			RAC40256-1 (1) & RAC40256-2 (1)
B200C (C-12F) with McCauley De-ice with Beech STC and McCauley De-ice with Pratt & Whitney PT6A-42 Engines	4HFR34C754/94LA-X	B-40245-52	RA40330	C-40151 C-40363 Assy.			RAC40371-1 (1) & RAC40371-2 (1)
300 T-6 Texan II JPATS with Pratt & Whitney Engines	HC-E4A-2A			4E3196-1			RA2620-1 (6)
300, 350, Super King Air with Pratt & Whitney Engines	HC-B4MP-3	4E2575-7 4E2575-10	RA-2117-8 RA2192-2		RA2190-1	RA2111U-ROD (2)	RA1543-7 (2)
1900 Airliner with Pratt & Whitney Engines	HC-B4MP-3	4E2560-10	RA2192-2	4E3197-1	RA2190-3	RA2111U-ROD (2)	RA1543-7 (2)
1900D with <b>Heavy Duty</b> Brush Block with Pratt & Whitney Engines	HC-E44A-3	4E3400-1 4E3017-1	RA2626-1	4E3196-1			RA2620-1 (6)
<b>Beriev</b>							
BE-32 with Pratt & Whitney Engines	HC-E4P-3BX-1	4E3017-1	RA2626-1		RA2190-1	RA2111U-ROD (2)	RA1543-7 (2)



Aircraft Manufacturer and Model # Notes	Propeller Model #	De-Icer OEM PN	Wire Harness PN / Hub Extender PN	Solid Block OEM PN	Modular Brush Block Assy. PN	Brush Module PN (Quantity)	Brush PN (Quantity)
<b>Bombardier - see de-Havilland</b>							
<b>British Aerospace - see Handley Page</b>							
<b>Britten-Norman / Pilatus Britten-Norman</b>							
BN-2 Islander	HC-C2YK-2B	4E2200-4	RA2150	4E1350-2			RA1306-1 (3)
BN-2A Islander				4E1350-5			RA1543-2 (3)
BN-2A Mark III Trilandier					RA2146-1	RA2111U-ROD (3)	RA1543-7 (3)
BN-2A Left Prop with <b>Air Conditioning</b> with Lycoming Engines				4E1908-1 (AC)			RA1543-1 (3)
BN2T with Allison Engines	HC-C3YF-2CF	4E2271-10	RA2150		RA2162-2	RA2111U-ROD (2)	RA1543-7 (2)
BN2T with Lycoming Engines	HC-C3YF-2CUF	4E1188-4					
BN2T-(4) with Allison Engines	HC-C3YF-5F	4E3101-1	RA2150		RA2162-2	RA2111U-ROD (2)	RA1543-7 (2)
<b>CASA / Construcciones Aeronauticas</b>							
C-212 with AirResearch Engines	HC-B3TN-5			4E1387-5			RA1543-1 (2) & RA1543-2 (1)
					RA2142-1	RA2111U-ROD (3)	RA1543-7 (3)
C-212-100 with AirResearch Engines	HC-B4TN-5EL	4E1601-5	RA1989-2	4E1387-5			RA1543-1 (2) & RA1543-2 (1)
					RA2142-1	RA2111U-ROD (3)	RA1543-7 (3)
C-212-200 with AirResearch Engines	HC-B4MN-5AL	4E2336-10 4E2336-12	RA2192-2 RA2192-2		RA2162-2	RA2111U-ROD (2)	RA1543-7 (2)
<b>Cessna / Textron</b>							
182S, 182T, T182T with McCauley De-ice with Lycoming Engine	B3D36C442/80VSB-X, B3D36C432/80VSA-X			C-40189 C-40179 Assy.			RAB40189 (2)
182S, T182T with McCauley De-ice with Lycoming TIO-540-AK1A, -AC1A5, -AJ1A	B3D36C442/80VSB-X B3D36C432/80VSA-X			C-40151 C-40660 Assy.			RAC40522-1 (1) & RAC40522-2 (1)
T182T with McCauley De-ice (Phenolic Block) with Lycoming Engine	B3D36C442/80VSB-X, B3D36C432/80VSA-X			C-40011 C-40010 Assy.			RAB40012 (2)
T182T with McCauley (Thermoplastic Block) with Lycoming Engine	B3D36C442/80VSB-X, B3D36C432/80VSA-X			C-40189 C-40179 Assy.			RAB40189 (2)
T182, TR182 with McCauley De-ice with Lycoming O-540-L3C5D Engine	B3D32C407/82NDA-X			C-40189 C-40179 Assy.			RAB40189 (2)
T182, TR182 with McCauley De-ice (Phenolic Block) with Lycoming Engine	B2D32C407/82NDA-3			C-40011 C-40010 Assy.			RAB40012 (2)
T182, TR182 with McCauley De-ice (Thermoplastic Block) with Lycoming O-540-L3C5D Engine	B2D32C407/82NDA-3			C-40189 C-40179 Assy.			RAB40189 (2)
TR182 Skylane with Lycoming Engine	B2D34C214 2				RA2171	RA2111U-ROD (2)	RA1543-7 (2)
206H T206H TU206G U206G with Soloy STC SA2353NM with Allison Engine	HC-C3YN-5A	4E2200-10	RA2150		RA2162-2	RA2111U-ROD (2)	RA1543-7 (2)
206H, T206H with McCauley (Phenolic Block)	B3D36C442/80VSB-X, B3D36C432/80VSA-X			C-40011 C-40010 Assy.			RAB40012 (2)
206H, T206H with McCauley De-ice with McCauley De-ice with Lycoming TIO-540-AK1A, -AC1A5, -AJ1A	B3D36C442/80VSB-X, B3D36C432/80VSA-X			C-40151 C-40660 Assy.			RAC40522-1 (1) & RAC40522-2 (1)
TU206G with McCauley De-ice (Phenolic Block) with Continental TSIO-520-M Engine	D3A34C402/90DFA-X			C-40011 C-40055 Assy.			RAB40046
TU206G with McCauley (Thermoplastic Block) with Continental TSIO-520-M Engine	D3A34C402/90DFA-X			C-40151 C-40187 Assy.			RAB40193
208, 208A, 208B Caravan with Pratt & Whitney Engines	HC-B3MN-3	4E2336-12	RA2192-2		RA2190-1	RA2111U-ROD (2)	RA1543-7 (2)
208, 208A, 208B Caravan with Century Aviation STC SA9854SW with Pratt & Whitney Engine	HC-B3MN-3	4E2560-10	RA2192-2				



Aircraft Manufacturer and Model # Notes	Propeller Model #	De-Icer OEM PN	Wire Harness PN / Hub Extender PN	Solid Block OEM PN	Modular Brush Block Assy. PN	Brush Module PN (Quantity)	Brush PN (Quantity)
208, 208A, 208B Caravan with Hartzell STC SA02181AK with Pratt & Whitney Engine	HC-B3TN-3AF/3AFY	4E2560-10	RA2192-2		RA2190-1	RA2111U-ROD (2)	RA1543-7 (2)
208, 208A, 208B Caravan with Hartzell STC SA02092AK with Pratt & Whitney Engine	HC-B3TN-D4N/3R	4E2560-10	RA2192-2		RA2190-1	RA2111U-ROD (2)	RA1543-7 (2)
208, 208A, 208B, Caravan, w/ McCauley De-ice with McCauley De-ice with Pratt & Whitney PT6A-114, -114A	3GFR34C703/106GA-X	B-40245-54	RA40531	C-40151 C-40257 Assy.			RAC40256-1 (1) & RAC40256-2 (1)
208, 208A, 208B, Caravan, w/ McCauley De-ice with Cessna STC SA02168CH, McCauley De-ice with Pratt & Whitney PT6A-114, -114A	4HFR34C775/96MGA-0	B-40245-54	RA40585	C-40151 C-40257 Assy.			RAC40256-1 (1) & RAC40256-2 (1)
210 with Continental Engine	E2A34C70 D3A32C88			4E1387-4, -6			RA1543-1 (2) & RA1543-2 (1)
					RA2142-1	RA2111U-ROD (3)	RA1543-7 (3)
210K, 210L, 210M, 210N with John Jewll STC SA00553AT with Continental Engine	PHC-J3YF-1RF				RA2142-2	RA2111U-ROD (3)	RA1543-7 (3)
P210N with O&N Aircraft STC SA1003NE with Continental Engine	HC-B3TF-7A				RA2162-2	RA2111U-ROD (2)	RA1543-7 (2)
210N, 210R, P210N, T210N, w/ McCauley De-ice (Phenolic Block) with Continental IO-520-L, -P, -AF, -R Engines	D3A34C404/80VA-X, D3A34C402/90DFA-X			C-40011 C-40055 Assy.			RAB40046 (2)
210N, 210R, P210N, T210N, w/ McCauley De-ice (Thermoplastic Block) with Continental IO-520-L, -P, -AF, -R Engines	D3A34C404/80VA-X, D3A34C402/90DFA-X			C-40151 C-40187 Assy.			RAB40193 (2)
P210R, T210R with McCauley De-ice with Continental IO-520-L, -P, -AF, -R Engines	D3A36C410/80VMB-X			C-40151 C-40187 Assy.			RAB40193 (2)
T303 with McCauley De-ice with Continental IO-520-AE, LTSIO-520-AE	3AF32C506/82NEA-X 3AF32C507/L82NEA-X			C-40151 C-40187 Assy.			RAB40193 (2)
310 with Hartzell STC SA234CH with Continental TSIO-520 Engines with Continental IO-470 Engines	PHC-C3YF-2UF PHC-J3YF-2UF	4E1601-10	RA2067-3	4E1294			RA1306-3 (3)
					RA2142-1 (520)	RA2111U-ROD (3)	RA1543-7 (3)
					RA2142-2 (470)	RA2111U-ROD (3)	RA1543-7 (3)
310 thru H 320 Goodrich STC SA1-506 with Continental Engines	HC-A2XF(VF/MVF)-2			4E1294			RA1306-3 (3)
					RA2142-1	RA2111U-ROD (3)	RA1543-7 (3)
					RA2142-2	RA2111U-ROD (3)	RA1543-7 (3)
310C, D, E, F, G, H, E310H, 310I, 310J-1 with McCauley De-ice with Continental IO-470-D, -U Engines	3AF32C528/82NEA-X			C-40151 C-40179 Assy.			RAB40189 (2)
310J, K, L, N, E310J with McCauley De-ice with Continental IO-470-U, -V, -VO Engines	3AF32C512/82NEA-X			C-40151 C-40187 Assy.			RAB40193 (2)
310P, 310Q with McCauley De-ice (Phenolic Block) with Continental IO-470-VO Engines	D2AF34C71/84JF-X 3AF32C87/82NC-X 3AF32C504/82NEA-X			C-40011 C-40055 Assy.			RAB40046 (2)
310P, 310Q with McCauley De-ice (Thermoplastic Block) with Continental IO-470-VO Engines	D2AF34C71/84JF-X 3AF32C87/82NC-X 3AF32C504/82NEA-X 3AF32C528/82NEA-X			C-40151 C-40187 Assy.			RAB40193 (2)
310R with McCauley De-ice (Phenolic Block) with Continental 520-M, MB Engines	3AF32C504/82NEA-X			C-40011 C-40055 Assy.			RAB40046 (2)
310R with McCauley De-ice (Thermoplastic Block) with Continental 520-M, MB Engines	3AF32C504/82NEA-X 3AF32C528/82NEA-X			C-40151 C-40187 Assy.			RAB40193 (2)
T310P, T310Q T310R with RAM STC SA09971SC with Continental Engines		4E1601-14	4E1967-3				
310R SN. 310R0938 - 310R2109 with McCauley De-ice with Continental Engines			RA-C165013-0604				
T310P, T310Q with McCauley De-ice (Phenolic Block) with Continental 520-B, BB Engines	D2AF34C71/84JF-X 3AF32C87/82NC-X 3AF32C504/82NEA-X			C-40011 C-40010 Assy.			RAB40012 (2)
T310P, T310Q with McCauley De-ice (Thermoplastic Block) with Continental 520-B, BB Engines	D2AF34C71/84JF-X 3AF32C87/82NC-X 3AF32C504/82NEA-X			C-40151 C-40179 Assy.			RAB40189 (2)
T310P, T310Q with Cessna STC and McCauley De-ice with Continental 520-B, BB Engines	3AF32C528/82NEA-X			C-40151 C-40187 Assy.			RAB40193 (2)



Aircraft Manufacturer and Model # Notes	Propeller Model #	De-Icer OEM PN	Wire Harness PN / Hub Extender PN	Solid Block OEM PN	Modular Brush Block Assy. PN	Brush Module PN (Quantity)	Brush PN (Quantity)
320D, 320E 320F with RAM STC SA09971SC with Continental Engines		4E1601-14	4E1967-3				
320D, 320E, 320F, Skynight, with McCauley De-ice (Phenolic Block) TSIO-520-B, -BB, -E, -EB, -K, -KB, -N, -NB, -VB	3AF32C504/82NEA-X 3AF32C505/82NEA-X			C-40011 C-40010 Assy.			RAB40012 (2)
320D, 320E, 320F, with McCauley De-ice (Thermoplastic Block) TSIO-520-B, -BB, -E, -EB, -K, -KB, -N, -NB, -VB	3AF32C504/82NEA-X 3AF32C505/82NEA-X			C-40151 C-40179 Assy.			RAB40189 (2)
335 SN335-0001 and up, with McCauley De-ice with Continental Engines			RA-C165013-0604				
336 337 with Continental Engines	D2AF34C59 D2AF34C300 D2AF34C301			3E1387 3E1387-5			RA1306-1 (2) & RA1306-2 (1) RA1543-1 (2) & RA1543-2 (1) RA1543-7 (3)
340, 340A with RAM STC SA09971SC with Continental Engines		4E1601-14	4E1967-3				
340A S/N 340A0314-340A1215 with McCauley De-ice with Continental Engines			RA-C165013-0604				
340, 340A with McCauley De-ice (Phenolic Block) TSIO-520-B, -BB, -E, -EB, -K, -KB, -N, -NB, -VB	3AF32C504/82NEA-X 3AF32C505/82NEA-X			C-40011 C-40010 Assy.			RAB40012 (2)
340, 340A with McCauley De-ice (Thermoplastic Block) TSIO-520-B, -BB, -E, -EB, -K, -KB, -N, -NB, -VB	3AF32C504/82NEA-X 3AF32C505/82NEA-X			C-40151 C-40179 Assy.			RAB40189 (2)
340, 340A with Cessna STC McCauley (Phenolic Block) with Continental TSIO-520-J, -N, -NB, -VB	3AF32C515/82NLA-X			C-40011 C-40010 Assy.			RAB40012 (2)
340, 340A Cessna STC McCauley (Thermoplastic Block) with Continental TSIO-520-J, -N, -NB, -VB	3AF32C515/82NLA-X			C-40151 C-40179 Assy.			RAB40189 (2)
401, 401A, 401B with McCauley De-ice (Phenolic Block) TSIO-520-B, -BB, -E, -EB, -K, -KB, -N, -NB, -VB	3AF32C504/82NEA-X 3AF32C505/82NEA-X			C-40011 C-40010 Assy.			RAB40012 (2)
401, 401A, 401B with McCauley De-ice (Thermoplastic Block) TSIO-520-B, -BB, -E, -EB, -K, -KB, -N, -NB, -VB	3AF32C504/82NEA-X 3AF32C505/82NEA-X			C-40151 C-40179 Assy.			RAB40189 (2)
340A S/N 340A0314-340A1215 with McCauley De-ice with Continental Engines			RA-C165013-0604				
402 402A, 402B, 402C	3AF32C505	4E2200-10	RA2192-3				
402 with American Jet STC SA2424WE with Allison Engine	HC-B3TF-7	4E2200-10	RA2192-3	4E1387-5			RA1543-1 (2) & RA1543-2 (1) RA1543-7 (3)
402C with RAM STC SA09971SC with Continental Engines		4E1601-14	RA2067-3				
402, 402A, 402B, 402C, Businessliner, with McCauley De-ice (Phenolic Block) with Continental Engines TSIO-520-B, -BB, -E, -EB, -K, -KB, -N, -NB, -VB	3AF32C504/82NEA-X 3AF32C505/82NEA-X			C-40011 C-40010 Assy.			RAB40012 (2)
402, 402A, 402B, 402C with McCauley De-ice (Thermoplastic Block) with Continental Engines TSIO-520-B, -BB, -E, -EB, -K, -KB, -N, -NB, -VB	3AF32C504/82NEA-X 3AF32C505/82NEA-X			C-40151 C-40179 Assy.			RAB40189 (2)
402, 402C with Cessna STC for McCauley (Phenolic Block) with Continental TSIO-520-J, -N, -NB, -VB	3AF32C515/82NLA-X			C-40011 C-40010 Assy.			RAB40012 (2)
402, 402C Cessna STC McCauley (Thermoplastic Block) with Continental TSIO-520-J, -N, -NB, -VB	3AF32C515/82NLA-X			C-40151 C-40179 Assy.			RAB40189 (2)
402B S/N 402B1238 & up with McCauley De-ice with Continental Engines			RA-C165013-0602				
402B S/N 402B1238 & up with McCauley De-ice with Continental Engines			RA-C165013-0604				
402C S/N 402C0001 - 402C0406 with McCauley De-ice with Continental Engines			RA-C165013-0604				



Aircraft Manufacturer and Model # Notes	Propeller Model #	De-Icer OEM PN	Wire Harness PN / Hub Extender PN	Solid Block OEM PN	Modular Brush Block Assy. PN	Brush Module PN (Quantity)	Brush PN (Quantity)
402C with RAM STC SA09971SC with Continental Engines		4E1601-14	RA2067-3				
404 Titan with McCauley De-ice (Phenolic Block) with Continental GTSIO-520-M Engines	3FF32C501/90UMB-X			C-40011 C-40010 Assy.			RAB40012 (2)
404 with McCauley De-ice (Thermoplastic Block) with Continental GTSIO-520-M Engines	3FF32C501/90UMB-X			C-40151 C-40179 Assy.			RAB40189 (2)
414A, Chancellor, w/ RAM Conv. with RAM STC SA09971SC with Continental Engines	PCH-C3YF-2UF	4E1601-14	RA2067-3				
414, 414A with McCauley De-ice (Phenolic Block) with Continental TSIO-520-J, -JB, -N, -NB Engine	3AF32C505/82NEA-X (P5055186-0119) (P5055186-0419)			C-40011 C-40010 Assy.			RAB40012 (2)
414, 414A with McCauley De-ice (Thermoplastic Block) with Continental TSIO-520-J, -JB, -N, -NB Engine	3AF32C505/82NEA-X (P5055186-0119) (P5055186-0419)			C-40151 C-40179 Assy.			RAB40189 (2)
414, 414A with Cessna STC McCauley (Phenolic Block) with Continental TSIO-520-J, -N, -NB, -VB	3AF32C515/82NLA-X			C-40011 C-40010 Assy.			RAB40012 (2)
414, 414A Cessna STC McCauley (Thermoplastic Block) with Continental TSIO-520-J, -N, -NB, -VB	3AF32C515/82NLA-X			C-40151 C-40179 Assy.			RAB40189 (2)
RAM 414-AW with Cessna STC McCauley De-ice with Continental TSIO-520-A	3AF36C514/80MFA-X			C-40151 C-40179 Assy.			RAB40189 (2)
414 S/N 414-0950 & up with McCauley De-ice with Continental Engines			RA-C165013-0604				
414A S/N 414A0001-414A0607 with McCauley De-ice with Continental Engines			RA-C165013-0604				
414, 414A with RAM STC SA09971SC with Continental Engines		4E1601-14	RA2067-3				
421, 421A, 421B with McCauley De-ice (Phenolic Block) with Continental GTSIO-520-D, -H Engines	3AF37C516/90LFB-0 P5167110-0119			C-40011 C-40010 Assy.			RAB40012 (2)
421, 421A, 421B with McCauley De-ice (Thermoplastic Block) with Continental GTSIO-520-D, -H Engines	3AF37C516/90LFB-0 P5167110-0119			C-40151 C-40179 Assy.			RAB40189 (2)
421C with RAM STC SA10185SC with Continental Engines	PHC-C3YF-2UF	4E1601-14	RA2067-3				
421C with McCauley De-ice (Phenolic Block) with Continental GTSIO-520-L, -N Engines	3AFF32C501/90UMB-X			C-40011 C-40010 Assy.			RAB40012 (2)
421C with McCauley De-ice (Thermoplastic Block) with Continental GTSIO-520-L, -N Engines	3AFF32C501/90UMB-X			C-40151 C-40179 Assy.			RAB40189 (2)
425 with Pratt & Whitney Engines	HC-B3TN-3	4E1188-6	RA1989-7		RA2144-1	RA2111U-ROD (3)	RA1543-7 (3)
425 with McCauley De-ice with Pratt & Whitney PT6A-112 Engines	3GFR34C701/93KB-X			C-40151 C-40179 Assy.			RAB40189 (2)
425 with Cessna STC for McCauley De-ice with Pratt & Whitney PT6A-112, -135 Engines	4HR34C762/94LMA-X	B-40245-52	RA40330	C-40151 C-40257 Assy.			RAB40256-1 (1) & RAB40256-2 (1)
425 with Pratt & Whitney Engines					RA2144-2	RA2111U-ROD (3)	RA1543-7 (3)
441 with AirResearch Engines	HC-BTN-5E/M	4E1188-6	RA1989-2				
441 with Executive Wings/Hartzell STC SA00058AT with Garrett Engines	HC-E4N-5	4E2271-10	RA2192-4		RA2190-2	RA2111U-ROD (2)	RA1543-7 (2)
441 with McCauley De-ice with TPE331-8, -10 Engines	3GFR34C601/93JA-X			C-40151 C-40187 Assy.			RAB40193 (2)
441 with Cessna STC for McCauley De-ice with TPE331-8, -10 Engines	4HFR34C661/90LNA-X	B-40245-56	RA40585	C-40151 C-40179 Assy.			RAB40189 (2)

Daher - See Socata



Aircraft Manufacturer and Model # Notes	Propeller Model #	De-icer OEM PN	Wire Harness PN / Hub Extender PN	Solid Block OEM PN	Modular Brush Block Assy. PN	Brush Module PN (Quantity)	Brush PN (Quantity)
<b>deHavilland / Bombardier / Viking Air Limited</b>							
DHC-4 Caribou with Pen Turbo STC ST01294NY with Pratt & Whitney Engines	HC-B5MA-3A				RA2190-2	RA2111U-ROD (2)	RA1543-7 (2)
DHC-6 Twin Otter with Pratt & Whitney Engines	HC-B3TN-3	4E1188-5	RA1989-2	4E1311-2			RA1543-1 (2) RA1543-2 (1)
DHC-6-300 with Field Aviation STC SA00023NY with Pratt & Whitney Engines	HC-D4N-3A				RA2190-2	RA2111U-ROD (2)	RA1543-7 (2)
DHC-6-300 with McCauley De-ice with Pratt & Whitney PT6A-27 Engines	4HFR34C764/90LNA-X	B-40245-52	RA40330				
<b>Czech Turbolet</b>							
L-410 with Pratt & Whitney Engines	HC-B3TN-3D HC-B4TN-3D	4E1188-5	RA1989-2	4E1311-2			RA1543-1 (2) RA1543-2 (1)
					RA2144-1	RA2111U (3)	RA1543-7 (3)
<b>deHavilland</b>							
DHC-4 Caribou with Pen Turbo STC ST01294NY with Pratt & Whitney Engines	HC-B5MA-3A				RA2190-2	RA2111U-ROD (2)	RA1543-7 (2)
DCH-6 Twin Otter with Pratt & Whitney Engines	HC-B3TN-3	4E1188-5	RA1989-2	4E1311-2			RA1543-1 (2) & RA1543-2 (1)
DCH-6 Field Aviation STC SA00023NY with Pratt & Whitney Engines	HC-D54N-3A				RA2190-2	RA2111U-ROD (2)	RA1543-7 (2)
DCH-6-300			RA2192-4				
<b>Dornier</b>							
DO128-6 with Pratt & Whitney Engines	HC-B3TN-3D	4E1188-5	RA1989-2		RA2144-1	RA2111U (3)	RA1543-7 (3)
DO228 with Pratt & Whitney Engines	HC-B3TN-5HL/ML	4E2635-10 4E2598-10	RA2469-1		RA2142-1	RA2111U (3)	RA1543-7 (3)
<b>Douglas</b>							
DC3A, DC-3C Greenwich Aircraft STC SA3820SW with Pratt & Whitney Engines	HC-B5MA-3		RA1989-4		RA2190-1	RA2111U-ROD (3)	RA1543-7 (3)
DC-3C with Basler STC SA4840NM with Pratt & Whitney Engines	HC-B5MA-3J	4E2595-7	RA2117-10		RA2190-2	RA2111U-ROD (2)	RA1543-7 (2)
<b>Embraer</b>							
EMB110 Bandeirante with Pratt & Whitney Engines	HC-B3TN-3	4E1188-6 4E2200-10	RA1989-2 RA2192-2	4E1311-2			RA1543-1 (2) & RA1543-2 (1)
					RA2144-1	RA2111U-ROD (3)	RA1543-5 (3)
EMB121 with Pratt & Whitney Engines	HC-B4TN-3	4E188-5	RA1989-3		RA2144-1	RA2111U-ROD (3)	RA1543-5 (3)
312A with Pratt & Whitney Engines	HC-B3TN-3	4E1188-6	RA1989-2		RA2144-1	RA2111U-ROD (3)	RA1543-5 (3)
312A, 312F with Pratt & Whitney Engines	HC-B3TN-3	4E2092-2	RA2192-2		RA2190-1	RA2111U-ROD (3)	RA1543-5 (3)
<b>Evangel Air</b>							
4300-300 with Lycoming Engine	HC-C2YK			4E1350-5			RA1543-2 (3)
					RA2146-1	RA2111U-ROD (3)	RA1543-7 (3)
<b>Fairchild / Swearingen</b>							
SA26-T, SA26-AT, with Garrett Engines SA226-T, SA226-AT, SA226-TC	HC-B3TN-5C	4E2200-10	RA2192-2	4E1387-1			RA1306-1 (2) & RA1306-2 (1)
				4E1387-5			RA1543-1 (2) & RA1543-2 (1)
					RA2142-1	RA2111U-ROD (3)	RA1543-7 (3)
SA26-T, SA26-AT, with Pratt & Whitney Engines SA226-T, SA226-AT, SA226-TC	HC-B3TN-3			4E1311, -1			RA1306-1 (2) & RA1306-2 (1)
				4E1311-2			RA1543-1 (2) & RA1543-2 (1)
					RA2144-1	RA2111U-ROD (3)	RA1543-7 (3)
SA26-T, SA26-AT with AiRsearch Engines SA226-T, SA226-AT, SA226-TC	HC-B3TN-5			4E1387-1			RA1306-1 (2) & RA1306-2 (1)
				4E1387-5			RA1543-1 (2) & RA1543-2 (1)
					RA2142-1	RA2111U-ROD (3)	RA1543-7 (3)



Aircraft Manufacturer and Model # Notes	Propeller Model #	De-icer OEM PN	Wire Harness PN / Hub Extender PN	Solid Block OEM PN	Modular Brush Block Assy. PN	Brush Module PN (Quantity)	Brush PN (Quantity)
SA227-TT, SA227-AT, SA227-TC with AiRsearch Engines	Dowty Rotol R321, R324	4E1188-6 4E2200-10	RA1989-2 RA2192-2			RA2111U-ROD (3)	RA1543-7 (3)
					RA2142-1	RA2111U-ROD (3)	RA1543-7 (3)
SA227-AC, -AT, -BC, -CC, -DC, Metroliner with McCauley De-ice with TPE331-11U, -12UA, -12UAR, -12UHR	4HFR34C652/L106LA-X		RA40387	C-40151 C-40331 Assy.			RAB40332 (2)
<b>Franks</b>							
Mohawk 298 BFG Hotrop Conversion Kit 67-024			RA2192-4				
<b>Government Aircraft Factories (G.A.F.)</b>							
N-22B Nomad with Allison Engines	HC-A3VF7	41188-5	RA1989-2	4E1387-5			RA1543-1 (2) & RA1543-2 (1)
					RA2142-1	RA2111U-ROD (3)	RA1543-7 (3)
<b>Gulfstream</b> - see Grumman American or Aero Commander							
<b>Handley Page / British Aerospace</b>							
137 Mk.1 wwith Jetstream STC SA2293SW with Pratt & Whitney Engines	HC-B3TN-3D	41188-5	RA1989-2	4E1311-2			RA1543-1 (2) & RA1543-2 (1)
					RA2144-1	RA2111U-ROD (3)	RA1543-7 (3)
<b>Harbin</b>							
Y1-11B with Continental Engines	PHC-C3YF-2KUF	4E2271-10	RA2150	3E2414-3			RA2426-3 (3)
					RA2144-1	RA2111U-ROD (3)	RA1543-7 (3)
Y-12 with Pratt & Whitney Engines	HC-B3TN-3B	4E1188-3B	RA1989-2		RA2144-1	RA2111U-ROD (3)	RA1543-7 (3)
Y-12 with Pratt & Whitney Engines	HC-B3TN-3D	41188-5	RA1989-2		RA2144-1	RA2111U-ROD (3)	RA1543-7 (3)
<b>Hawker Beechcraft</b> - see Beech							
<b>Israel Aircraft</b>							
101 Arava with Pratt & Whitney Engines	HC-B3TN-3D	41188-5	RA1989-2	4E1311-3			RA1543-1 (2) & RA1543-2 (1)
					RA2144-1	RA2111U-ROD (3)	RA1543-7 (3)
<b>Korean Aerospace Industries</b>							
KT-1 with Pratt & Whitney Engines	HC-B3TN-3C	4E2200-10	RA2192-2		RA2190-1	RA2111U-ROD (2)	RA1543-7 (2)
<b>Mitsubishi</b>							
MU-2 with AiRsearch Engines	HC-B3TN-5L	41188-7	RA1989-4	4E1387-5			RA1543-1 (2) & RA1543-2 (1)
					RA2142-1	RA2111U-ROD (3)	RA1543-7 (3)
MU-2 with AiRsearch Engines	HC-B4TN-5	4E2200-10 41188-5	RA2192-2 RA1989-2	4E1387-5			RA1543-1 (2) & RA1543-2 (1)
					RA2142-1	RA2111U-ROD (3)	RA1543-7 (3)
<b>Mooney</b>							
201 (M20J) with 14 Volt wth Lycoming Engine	B2D34C214				RA2144-1	RA2111U-ROD (3)	RA1543-7 (3)
201 (M20J) with 28 Volt wth Lycoming Engine	B2D34C214				RA2190-2	RA2111U-ROD (2)	RA1543-7 (2)
231 (M20K) wth Continental Engine	HO-V123				RA2142-1	RA2111U-ROD (3)	RA1543-7 (3)
252 (M20K) with 28 Volt wth Continental Engine	BHC-J2YF-1BF				RA2162-2	RA2111U-ROD (2)	RA1543-7 (2)
M20K with 14 Volt wth Continental Engine	PHC-J2YF-1B 2A34C216 PHC-J3YF-1RF				RA2142-1	RA2111U-ROD (3)	RA1543-7 (3)



Aircraft Manufacturer and Model # Notes	Propeller Model #	De-icer OEM PN	Wire Harness PN / Hub Extender PN	Solid Block OEM PN	Modular Brush Block Assy. PN	Brush Module PN (Quantity)	Brush PN (Quantity)
M20M with McCauley De-ice with Lycoming TIO-540-AF1A	B3D32C417/82NRD-X			C-40151 C-40521			RAC40522-1 (1) & RAC40522-2 (1)
M20R Ovation with McCauley De-ice with Continental TSIOL-550-G Engine	3A32C418/82NRC-X			C-40151 C-40257 Assy.			RAC40256-1 (1) & RAC40256-2 (1)
Rocket M20L, M20M, M20R with McCauley STC for McCauley De-ice with Continental TSIOL-550-A Engine	3AF32C525/80VMFA-X		RA2171-2	C-40151 C-40179 Assy.			RAB40189 (2)
<b>Partenavia / Vulcanair</b>							
P68 Observer with Lycoming Engines	HC-C2YK-2CUF HC-C3YK-2			4E1639			RA1543-1 (2) & RA1543-2 (1)
P68TC with Allison Engines	HC-B3TF-7A				RA2142-1	RA2111U-ROD (3)	RA1543-7 (3)
AP68TP with Allison Engines	HC-B3TF-7	4E2200-10	RA2192-2		RA2162-1	RA2111U-ROD (2)	RA1543-7 (2)
<b>Pilatus Britten-Norman - Also see Britten Norman</b>							
PC-6 with Pratt & Whitney Engine	HC-B3TN-3	4E1185-5 4E2200-10	RA1989-2 RA2192-2	4E1311-2			RA1543-1 (2) & RA1543-2 (1)
PC-6/B1-H2, PC-6/B2-H2, PC-6B/B2-H4 with Hartzell STC SA377CH with Pratt & Whitney Engine	HCD4N-3P	4E2271-10	RA2192-4		RA2144-1 RA2144-2	RA2111U-ROD (3) RA2111U-ROD (3)	RA1543-7 (3) RA1543-7 (3)
PC-7 with Pratt & Whitney Engine	HC-B3TN-3	4E2200-10	RA2192-2		RA2190-1	RA2111U-ROD (2)	RA1543-7 (2)
PC-7MK II with Pratt & Whitney Engine	HC-D4N-2	4E2271-10	RA2192-4		RA2144-2	RA2111U-ROD (3)	RA1543-7 (3)
PC-9 with Pratt & Whitney Engine	HC-D4N-2	4E2271-10	RA2192-4		RA2144-2	RA2111U-ROD (3)	RA1543-7 (3)
PC-12, PC-12/45, PC-12/47 with Pratt & Whitney Engine	HC-E4A-3D	4E3051-10	RA2460-4 RA2460-4HD				
<b>Piper / The New Piper Aircraft, Inc.</b>							
PA-23 Apache PA-23-160 Goodrich STC SA1-484 with Lycoming Engines	HC-A2LXL-2 C2YK-2	4E229-10	RA2192-2				
PA-23-250 Aztec with Goodrich STC SA1-485 with 14 Volt with Lycoming Engines	HC-A3XK-2	4E229-10	RA2192-2				
PA-30, -39 Twin Comanche, with Miller STC SA1151SW	HC-C2YK-2			4E1639			RA1543-1 (2) & RA1543-2 (1)
PA-31 Navajo Non-Pressurized Normal Rotation Propellers with Lycoming Engines	HC-E2YR-2	4E2271-10	RA2194-1	4E1350-2 4E1350-5			RA1306-1 (3) RA1543-2 (3)
					RA2146-1	RA2111U-ROD (3)	RA1543-7 (3)
PA-31 Non-Pressurized, Normal Rotation Propellers with Lycoming Engines	HC-E2YR-2	4E2271-10	RA2194-1	4E1350-2 4E1350-5			RA1306-1 (3) RA1543-2 (3)
					RA2146-1	RA2111U-ROD (3)	RA1543-7 (3)
PA-31 Non-Pressurized, Normal rotation propellers / No Air Conditioning with Lycoming Engines	BHC-3YR-2A		RA1649 Hub Ext.	4E1350-2 4E1350-5			RA1306-1 (3) RA1543-2 (3)
					RA2146-1	RA2111U-ROD (3)	RA1543-7 (3)
PA-31, PA-31-350 Non-Pressurized Normal rotation propellers / No Air Conditioning Right prop / Air conditioning with Lycoming Engines	HC-E3YR-2 (AF, ALF, ATF, ALTF)	4E2271-10 4E2200-10 (CR)	RA2194-1 RA2194-1 RA1649 Hub Ext.		RA2146-1	RA2111U-ROD (3)	RA1543-7 (3)
				4E1350-5			RA1543-2 (3)
				4E1908-1(A/C)			RA1543-1 (2) & RA1543-2 (1)
PA-31 Series, PA-31-325, PA-31-350 Colemill STC's SA970SO, SA1151SO Normal rotation propellers / No Air Conditioning Right prop / <b>Air conditioning</b> with Lycoming Engines	HC-C4YR-2	4E1601-7 4E1601-14 4E1188-7 (C/R)	RA2067-1 RA2067-3 RA2067-1				
				4E1350-5			RA1543-2 (3)
				4E1908-1(A/C)			RA1543-1 (2) & RA1543-2 (1)



Aircraft Manufacturer and Model # Notes	Propeller Model #	De-Icer OEM PN	Wire Harness PN / Hub Extender PN	Solid Block OEM PN	Modular Brush Block Assy. PN	Brush Module PN (Quantity)	Brush PN (Quantity)
PA-31-P Pressurized with Lycoming Engines	HC-C3YN-2L	4E2200-10	RA2194-3	4E1387-4,-6			RA1543-1 (2) & RA1543-2 (1)
PA-31-P-350 Pressurized with Lycoming Engines	HC-IC3YN-2UF	4E2271-10 4E2200-10 (CR)	RA2150 RA2150		RA2142-1	RA2111U-ROD (3)	RA1543-7 (3)
PA-31T, PA-31T1, PA-31T2 with Pratt & Whitney Engines	HC-B3TH-3B	4E1188-5	RA1989-2	4E1311-2			RA1543-1 (2) & RA1543-2 (1)
PA-31T, PA-31T1, PA-31T2 Aircraft Restorations STC SA0086SE with Pratt & Whitney Engines	HC-E4N-3B	4E1188-5	RA1989-2	4E1311-2	RA2144-1	RA2111U-ROD (3)	RA1543-7 (3)
PA-31T1A, PA-31T12A, PA-31T3, with Pratt & Whitney Engines	HC-B3TH-3B	4E2200-10	RA2194-2		RA2190-1	RA2111U-ROD (2)	RA1543-7 (2)
PA-31T, PA-31T1 with Piper STC and McCauley De-ice with Pratt & Whitney PT6A-28, -11 Engines	4HFR34C766/94LNA-X	B-40245-52	RA40330	C-40151 C-40179 Assy.			RAB40189 (2)
PA-34-200 Seneca Goodrich STC SA900EA with Lycoming Engines	HC-C2YK-2	4E2303-10 4E2292-10	RA2194-1 RA2194-1	4E1908-1			RA1543-1
PA-34-200T with Continental Engines	BHC-C2YF-2CLKF	4E1601-10 (Left)	RA2067-3		RA2142-1	RA2111U-ROD (3)	RA1543-7 (3)
PA-34-200T, PA-34-220T with 14 Volt with Continental Engines	BHC-C2YF-2CLKF	4E1601-10 (Left) 4E2303-10 (Left)	RA2067-3 RA2194-1	4E1387-5	RA2142-1	RA2111U-ROD (3)	RA1543-1 (2) & RA1543-2 (1)
PA-34-200T, PA-34-220T with 14 Volt with Continental Engines	3AF34C502/503 3AF34C508/509	4E2292-10 4E2303-10	RA2192-5 RA2192-5		RA2162-2	RA2111U-ROD (2)	RA1543-7 (2)
PA-34-200T, PA-34-220T with 14 Volt with Continental Engines	PHC-C3YF-2(L)KUF	4E2292-10 4E2303-10	RA2150 RA2150		RA2162-2	RA2111U-ROD (2)	RA1543-7 (2)
PA-34-220T with 28 Volt with Continental Engines	3AF32C522 (LH) 3AF32C523 (RH)				RA2162-2	RA2111U-ROD (2)	RA1543-7 (2)
PA-34-220T with 28 Volt with Continental Engines	BHC-J2YF-2CLUF				RA2162-2	RA2111U-ROD (2)	RA1543-7 (2)
PA42 Cheyenne with Pratt & Whitney Engines	HC-B3TH-3B	4E1188-5	RA1989-2	4E1311-2			RA1543-1 (2) & RA1543-2 (1)
PA-42, PA-42-720 with Piper STC and McCauley De-ice with Pratt & Whitney PT6A-41, -61 Engines	4HFR34C774/94LPA-X			C-40151 C-40179 Assy.	RA2144-1	RA2111U-ROD (3)	RA1543-7 (3)
PA-44-180 Seminole with Continental Engines	HC-C2YR-2C/CL	4E2292-10 4E2303-10	RA2150 RA2150		RA2190-1	RA2111U-ROD (2)	RA1543-7 (2)
PA-44-180 with Continental Engines	HC-C3YR-2/CL	4E2292-10 4E2303-10	RA2150 RA2150		RA2190-1	RA2111U-ROD (2)	RA1543-7 (2)
PA-46 Malibu with Continental Engine	HC-B3TN-3CX	4E3436-10	RA2192-2		RA2190-1	RA2111U-ROD (2)	RA1543-7 (2)
PA-46-310P with Continental Engine	BHC-C2YF-1BF				RA2190-1	RA2111U-ROD (2)	RA1543-7 (2)
PA-46-310P Hartzell STC SA01616CH with Continental Engine	PHC-G3YF-1E				R2171	RA2111U-ROD (2)	RA1543-7 (2)
PA-46-310P Malibu Power & Propeller STC SA01770CH with Continental Engine	PCH-G3YF-1E				R2171	RA2111U-ROD (2)	RA1543-7 (2)
PA-46-310P PA-46-350 with Lycoming Engine	HC-12YR-1BF				R2171	RA2111U-ROD (2)	RA1543-7 (2)
PA-46-310P PA-46-350 with Jetprop STC ST00541SE with Pratt & Whitney Engine	HC-E4N-31				RA2144-2	RA2111U-ROD (3)	RA1543-7 (3)
PA-46-310P PA-46-350 with Jetprop STC SA00541SE with Pratt & Whitney Engine	HC-E4N-3M	4E3462-1	RA2626-1		RA2144-2	RA2111U-ROD (3)	RA1543-7 (3)
PA-46-350P Meridian with Continental Engine	HC-13YR-1E				RA2171	RA2111U-ROD (2)	RA1543-7 (2)
PA-46-350P Hartzell STC SA01340CH with Continental Engine	HC-13YR-1E				RA2171	RA2111U-ROD (2)	RA1543-7 (2)



Aircraft Manufacturer and Model # Notes	Propeller Model #	De-Icer OEM PN	Wire Harness PN / Hub Extender PN	Solid Block OEM PN	Modular Brush Block Assy. PN	Brush Module PN (Quantity)	Brush PN (Quantity)
PA-46-500TP wth Pratt & Whitney Engine	HC-E4N-3Q				RA2144-2	RA2111U-ROD (3)	RA1543-7 (3)
PA-60-700P with Lycoming Engines	HC-C3YR-2/2L	4E2271-10 4E22-10	RA2150-2 RA2150-2		RA2171	RA2111U-ROD (2)	RA1543-7 (2)
<b>Reims</b>							
F406 wth Pratt & Whitney Engine	HC-E4N-3N HC-D4N-3N	4E2271-12	RA2192-4		RA2190-1	RA2111U-ROD (2)	RA1543-7 (2)
<b>Raytheon - see Beech</b>							
<b>Rockwell - see Aero Commander</b>							
<b>Short Brothers</b>							
SC7 with AiResearch Engines	HC-B4TN-5EL	4E1601-5	RA1989-2	4E1387-5			RA1543-1 (2) & RA1543-2 (1)
					RA2142-1	RA2111U-ROD (3)	RA1543-7 (3)
SC7 with AiResearch Engines	HC-B3TN-5			4E1387-1 4E1387-5			RA1306-1 (2) & RA1306-2 (1) RA1543-1 (2) & RA1543-2 (1)
					RA2142-1	RA2111U-ROD (3)	RA1543-7 (3)
SC7 with AiResearch Engines	HC-B3TN-5	4E1188-6	RA1989-2	4E1387-5			RA1543-1 (2) & RA1543-2 (1)
					RA2142-1	RA2111U-ROD (3)	RA1543-7 (3)
SC7 with AiResearch Engines	HC-B4TN-5	4E1188-5	RA1989-2	4E1387-5			RA1543-1 (2) & RA1543-2 (1)
					RA2142-1	RA2111U-ROD (3)	RA1543-7 (3)
SD3-30 wth Pratt & Whitney Engines	HC-B5TN	4E1601-7 4E2271-10	RA1989-4 RA2192-4	4E1311-3			RA1543-1 (2) & RA1543-2 (1)
					RA2144-1	RA2111U-ROD (3)	RA1543-7 (3)
SD3-60 wth Pratt & Whitney Engines	HC-B5MP-3C	4E2595-7 4E2595-10	RA2117-4 RA2192-2		RA2190-1	RA2111U-ROD (2)	RA1543-7 (2)



## RAPCO INC. DE-ICE CROSS REFERENCE GUIDE

FAA-PMA Approved De-ice Brushes and Wire Harnesses

To convert a BFG part number to RAPCO replace 4E with RA and add 100. For McCauley simply add RA to the part number.

### FAA-PMA Approved Propeller De-ice - Brushes, Wire Harnesses and Clamps

To convert a BFG part number to a RAPCO part number replace 2E, 3E or 4E with RA and add 100 to the number.

To convert a McCauley part number to a RAPCO simply add RA to the beginning of the part number.

### Wire Harnesses, Hub Extender Leads & Clamp

Description	RAPCO	B.F.G.	Safeway	McCauley	Cessna	Hartzell
<b>Wire Harness, Hub Extender Lead</b>						
Hub Extender Lead	RA1649	3E1549				
Hub Extender Lead	RA1656	3E1556				
Wire Harness	RA1989-2	4E1889-2				4H1889-2
Wire Harness	RA1989-3	4E1889-3	6959			4H1889-3
Wire Harness	RA1989-4	4E1889-4	6871			4H1889-4
Wire Harness	RA2067-1	4E1967-1	6962			4H1967-1
Wire Harness	RA2067-2	4E1967-2	6963			4H1967-2
Wire Harness	RA2067-3	4E1967-3	6964			4H1967-3
Wire Harness	RA2067-4	4E1967-4	6965			4H1967-4
Wire Harness	RA2117-4	3E2017-4	6881			3H2017-4
Wire Harness	RA-2117-8	3E2017-8	6951			3H2017-8
Wire Harness	RA2150	3E2050	6960			3H2050
Wire Harness	RA2150-2	3E2050-2	6961			3H2050-2
Wire Harness	RA-C165013-0602	4E2071-1	6260SW-1	B-40276-A	C165013-0602	
Wire Harness	RA2171-2	4E2071-2				
Wire Harness	RA-C165013-0604	4E2071-3	6479SW	B-5051	C165013-0604	103767
Wire Harness	RA2192-1	3E2092-1	7022			
Wire Harness	RA2192-2	3E2092-2	6887			
Wire Harness	RA2192-3	3E2092-3	6952			
Wire Harness	RA2192-4	3E2092-4	6834			
Wire Harness	RA2192-5	3E2092-5	6953			
Wire Harness	RA2192-6	3E2092-6	6954			
Wire Harness	RA2194-1	3E2094-1	6955			
Wire Harness	RA2194-2	3E2094-2	6956			
Wire Harness	RA2194-3	3E2094-3	6993			
Wire Harness	RA40387	3E2293-1	6875SW	B-40387		103764
Wire Harness	RA2460-4HD	3E2360-4				
Wire Harness w/ Clamps	RA2460-4	3E2360-4				3H2360-4
Wire Harness	RA2469-1	4E2369-1	6987			4E2369-1
Wire Harness	RA2469-2	4E2369-2	6941			4E2369-2
Wire Harness	RA2626-1	3E2526-1				3H2526-1
Wire Harness	RA40330		6719SW	B-40330		103763
Wire Harness	RA40531			B-40531		103765
Wire Harness	RA40585			B-40585		103766

<b>Clamp</b>						
Clamp	RATA1720SS-4T	TA1720SS4T		7931-172004		

For reference only.

20323



## Brushes & Accessories

Description	RAPCO	B.F.G.	Safeway	McCauley	Piper	Hartzell
<b>B.F.G. Style</b>						
Deice Brush with rod	RA1306-1	3E1206-1			753-427	
Deice Brush with rod	RA1306-2	3E1206-2				
Deice Brush with rod	RA1306-3	3E1206-3				
Nylon Spacer	RA1360	2E1260			758-102	
Deice Brush	RA1543-1	3E1443-1			758-175	
Deice Brush	RA1543-2	3E1443-2				
Deice Brush Kit (-4 brush)	RA1543-5	3E1443-5				
Deice Brush Kit (-6 w/rod)	RA1543-7	3E1443-7				
Wear Strip	RA2040-1	2E1940-1				
Universal Module	RA2111U	3E2011-1 thru -6 & -8				
Universal Module, w/ rod	RA2111U-ROD	3E2011-1 thru -5 & -10				
Modular Assembly	RA2142-1	3E2042-1				3H2042-1
Modular Assembly	RA2142-2	3E2042-2				3H2042-2
Modular Assembly	RA2144-1	3E2044-1				3H2044-1
Modular Assembly	RA2144-2	3E2044-2				3H2044-2
Modular Assembly	RA2146-1	3E2046-1				3H2046-1
Modular Assembly	RA2146-2	3E2046-2				3H2046-2
Modular Assembly	RA2146-3	3E2046-3				3H2046-3
Modular Assembly	RA2162-1	3E2062-1				3H2062-1
Modular Assembly	RA2162-2	3E2062-2				3H2062-2
Modular Assembly	RA2171	3E2071				
Modular Assembly	RA2190-1	3E2090-1				3H2090-1
Modular Assembly	RA2190-2	3E2090-2				3H2090-2
Modular Assembly	RA2190-3	3E2090-3				
Module Spacer	RA2318-3	4E2218-3				
Module Spacer	RA2318-4	4E2218-4				
Module Spacer	RA2318-5	4E2218-5				
Module Spacer	RA2318-6	4E2218-6				
Deice Brush	RA2426-1 sold as -2	3E2326-1				
Deice Brush Kit (CF)	RA2426-2	3E2326-2				
Deice Brush Kit (HD)	RA2620-1	3E2522-1				
<b>McCauley Style</b>						
Brush and Holder Assy.	RAB40012			B-40012		
Brush and Holder Assy.	RAB40046			B-40046		
Brush and Holder Assy.	RAB40189			B-40189		
Brush and Holder Assy.	RAB40193			B-40193		
Brush and Holder Assy.	RAB40332			B-40332		
Brush and Holder Assy.	RAC40256-1			C-40256-1		
Brush and Holder Assy.	RAC40256-2			C-40256-2		
Brush and Holder Assy.	RAC40371-1			C-40371-1		
Brush and Holder Assy.	RAC40371-2			C-40371-2		
Brush and Holder Assy.	RAC40464-1			C-40464-1		
Brush and Holder Assy.	RAC40464-2			C-40464-2		
Brush and Holder Assy.	RAC40522-1			C-40522-1		
Brush and Holder Assy.	RAC40522-2			C-40522-2		

For reference only.

32322



**MISC. DE-ICE INFO**

Replacements for BFG Style brush blocks: To convert BFG to Rapco part number, drop prefix and add RA plus 100 to part number

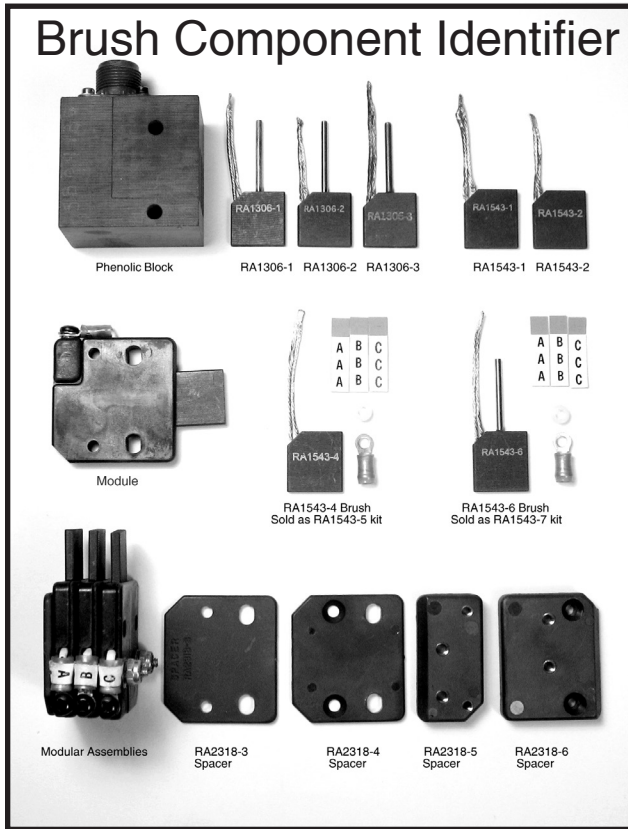

Brush Block Assy	Qty	Brush	Location
4E1294	3	RA1306-3	All
4E1311-1	2	RA1306-1	Top & Bottom
	1	RA1306-2	Middle
4E1311-2	2	RA1543-1	Top & Bottom
	1	RA1543-2	Middle
4E1311-3	2	RA1543-1	Top & Bottom
	1	RA1543-2	Middle
4E1350-1	3	RA1306-1	All
4E1350-2	3	RA1306-1	All
4E1350-3	3	RA1306-2	All
4E1350-4	3	RA1543-2	All
4E1350-5	3	RA1543-2	All
4E1350-6	2	RA1543-2	Top & Bottom
	1	RA1543-1	Middle
4E1387-1	2	RA1306-1	Top & Bottom
	1	RA1306-2	Middle
4E1387-2	2	RA1306-1	Top & Bottom
	1	RA1306-2	Middle
4E1387-3, 4E1387-5	2	RA1543-1	Top & Bottom
	1	RA1543-2	Middle
4E1387-4, 4E1387-6	2	RA1543-1	Top & Bottom
	1	RA1543-2	Middle
4E1560-2	3	RA1306-3	All
4E1639	2	RA1543-1	Top & Bottom
	1	RA1543-2	Middle
4E1749-2	2	RA1543-1	Both
4E1908-1	3	RA1543-1	All

Subject: How to measure brush

wear in Modular Assembly

Insert a 3/32 inch drill bit into the back of the RA2111U Universal module (as shown) and mark the depth on the drill.

**Note:** Make sure module is still installed, or that the Brush is protruding from module at the same distance as it would be installed on the slip ring (Approx. 1/16 Inch). Using a dial caliper measure the length of insertion (Dim. "D").

**Module Type**

**Rodded Module:**

Brush # RA1543-6

**Unrodded Module:**

Brush # RA1543-4

**Brush Min. Wear Dimension**

**Dimension "D"**

0.295 Inch

1.140 Inch

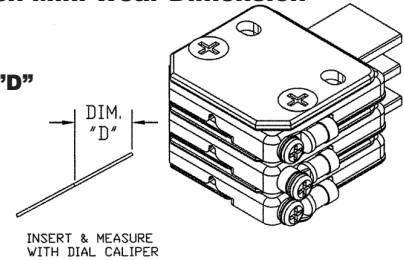

**Propeller De-Ice Brush Alignment**

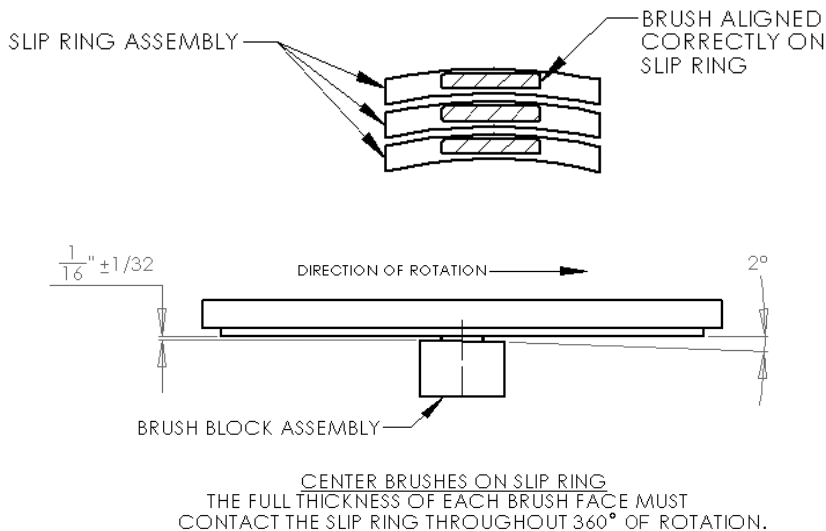

Before installing new de-ice brushes make sure the slip rings are clean and free of any oil. Check to see that the slip rings are smooth and have not separated from the potting material.

Proper brush alignment is important to prevent the brush from grounding and to maximize brush life.

1. Make sure that each carbon brush is adjusted so that it is centered on its respective slip ring.
2. The brush modular assembly should be positioned so that it sits at a 2 degree angle lagging the direction of rotation, and 1/16" away from the slip ring at its closest point.

**RA2142-1**

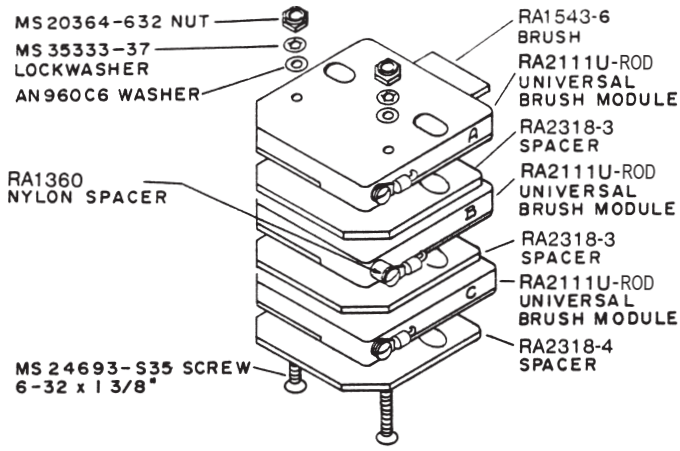

**RA2142-2**

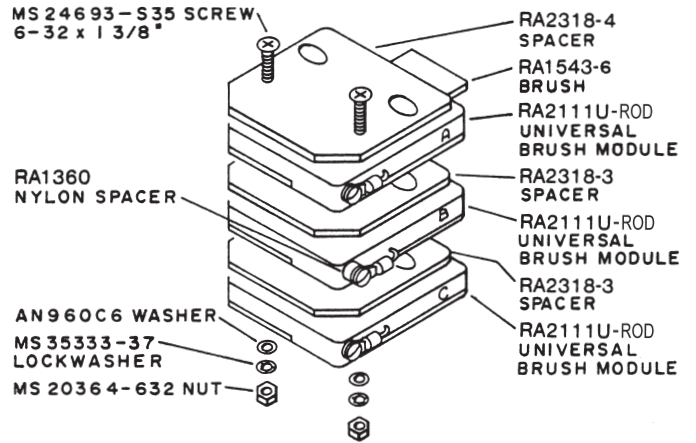

**RA2144-1**

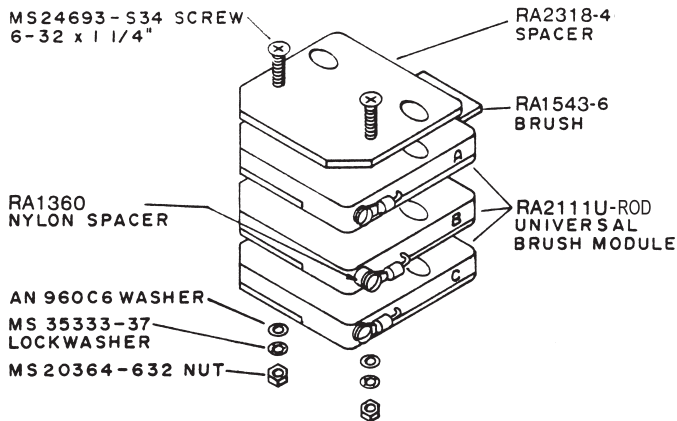

**RA2144-2**

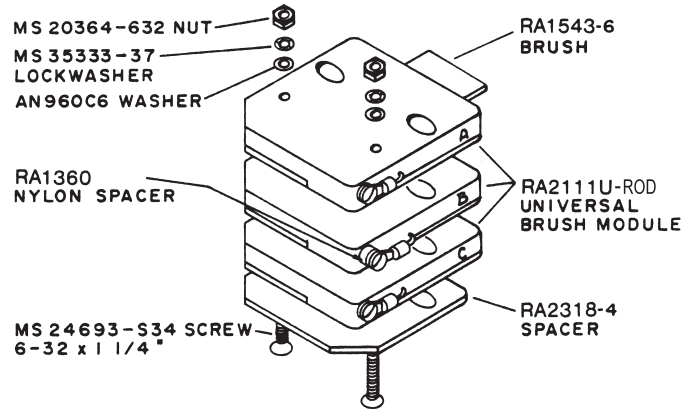

**RA2146-1 & 3**

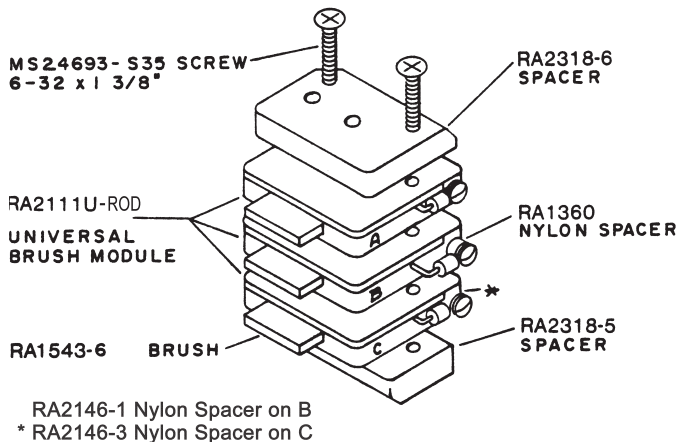

**RA2146-2**

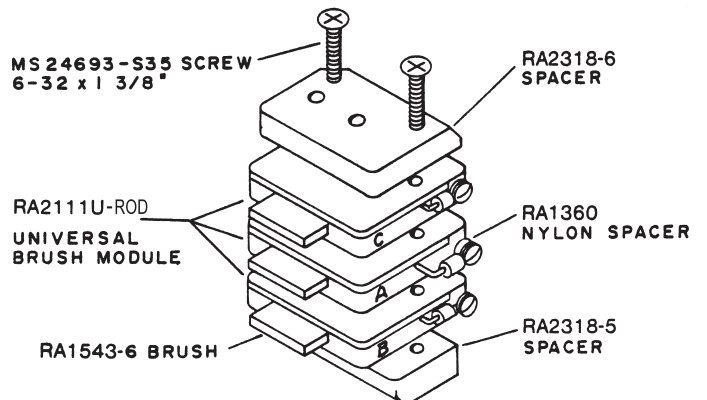

**RA2162-1**

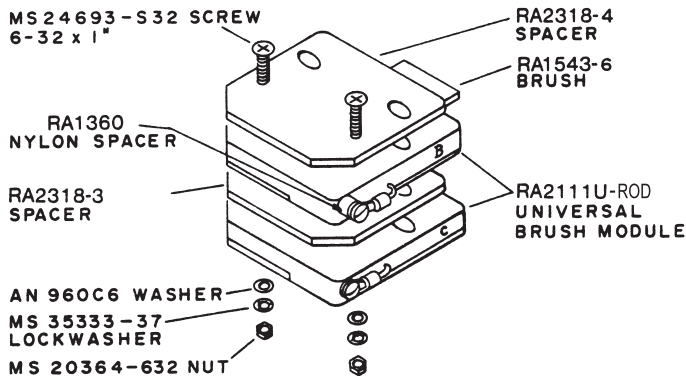

**RA2162-2**

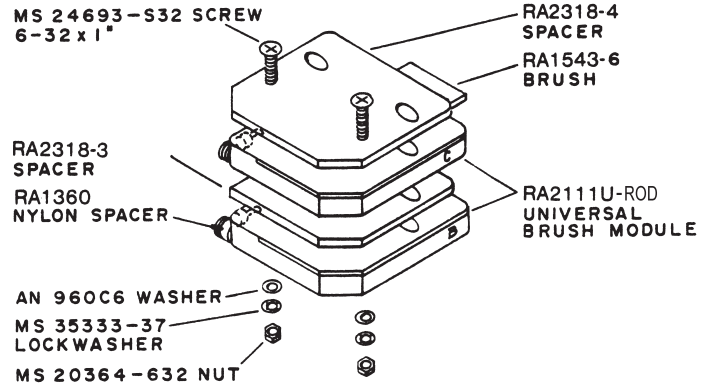

**RA2171**

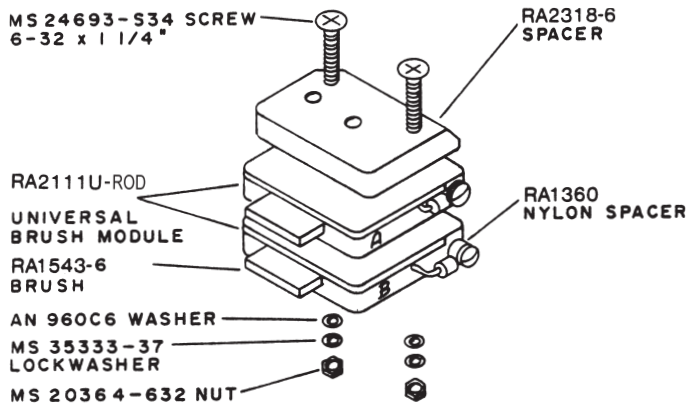

**RA2190-1**

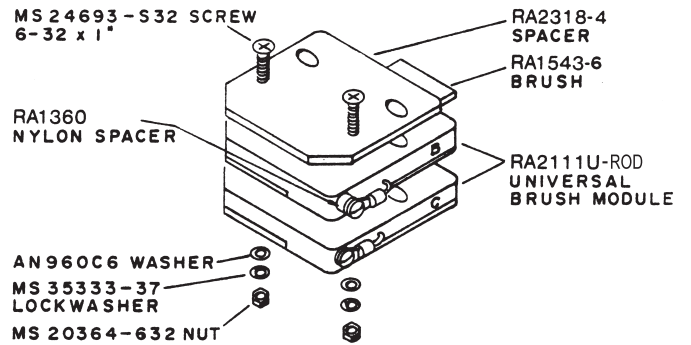

**RA2190-2**

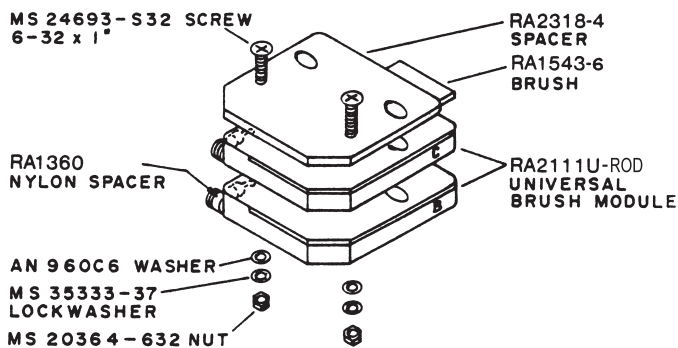

**RA2190-3**

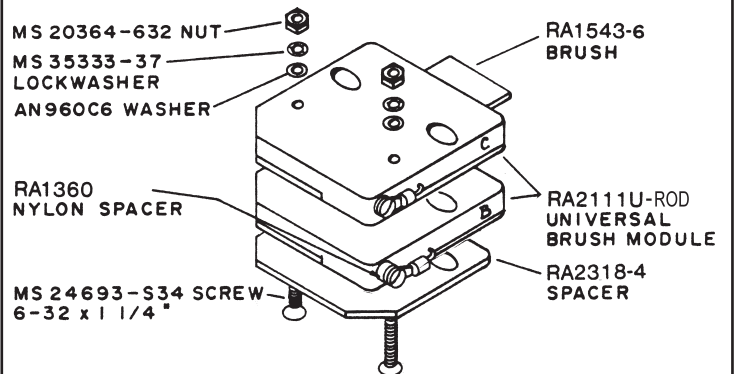

# McCauley De-Ice Brush & Holder Assembly



**RAB40012** used on  
Brush Block C-40011  
Brush Block Assembly  
C-40010

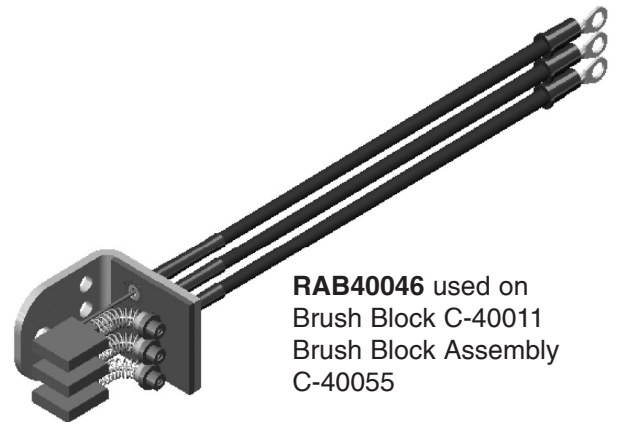

**RAB40046** used on  
Brush Block C-40011  
Brush Block Assembly  
C-40055



**RAB40189** used on  
Brush Block C-40151  
Brush Block Assembly  
C-40179

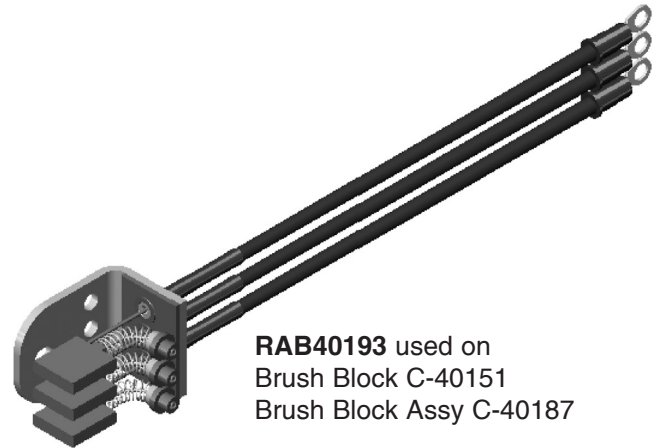

**RAB40193** used on  
Brush Block C-40151  
Brush Block Assy C-40187

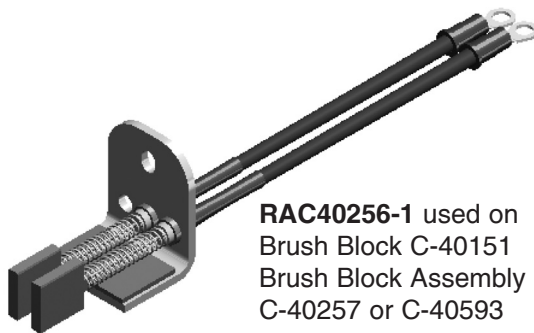

**RAC40256-1** used on  
Brush Block C-40151  
Brush Block Assembly  
C-40257 or C-40593

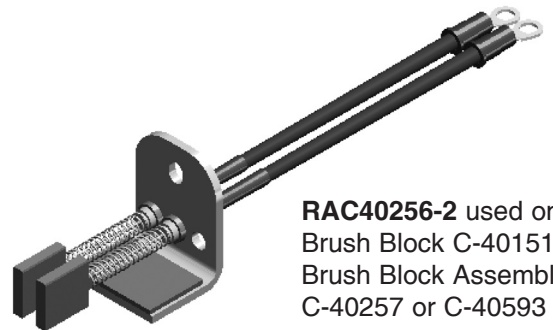

**RAC40256-2** used on  
Brush Block C-40151  
Brush Block Assembly  
C-40257 or C-40593

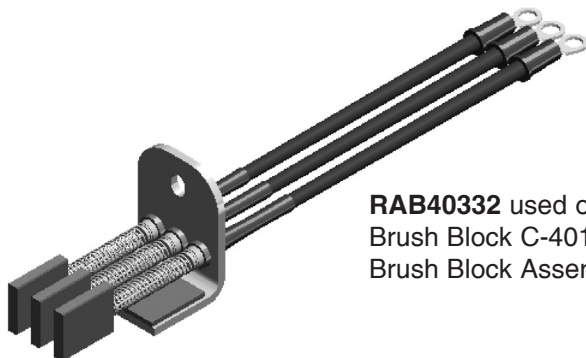

**RAB40332** used on  
Brush Block C-40151  
Brush Block Assembly C-40331



# McCauley De-Ice Brush & Holder Assembly

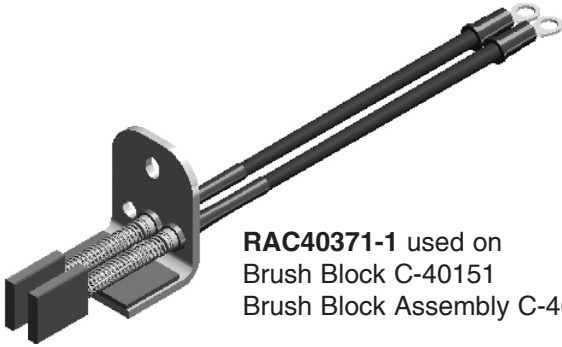

**RAC40371-1** used on  
Brush Block C-40151  
Brush Block Assembly C-40363



**RAC40371-2** used on  
Brush Block C-40151  
Brush Block Assembly C-40363



**RAC40464-1** used on  
Brush Block C-40411  
Brush Block Assembly  
C-40463 or C-40685



**RAC40464-2** used on  
Brush Block C-40411  
Brush Block Assembly  
C-40463 or C-40685

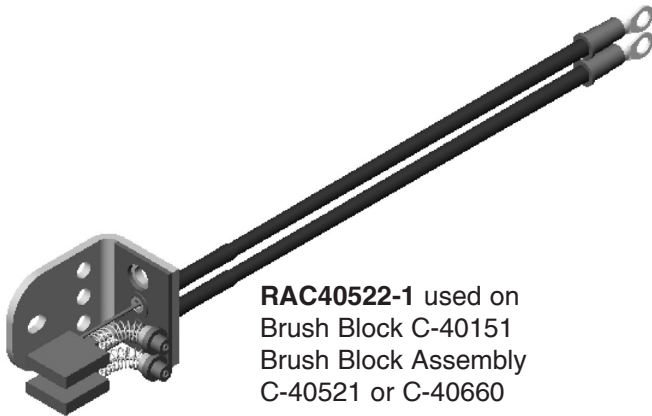

**RAC40522-1** used on  
Brush Block C-40151  
Brush Block Assembly  
C-40521 or C-40660

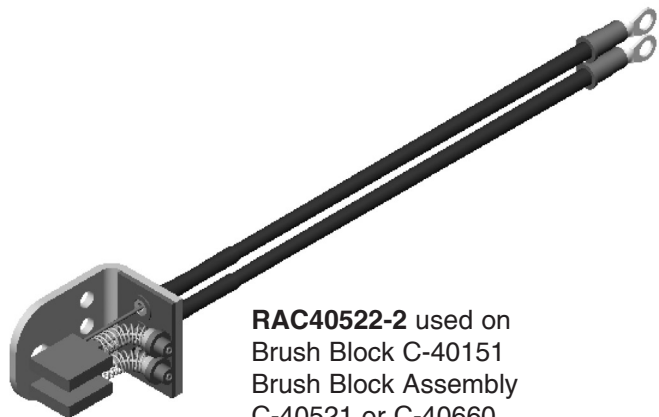

**RAC40522-2** used on  
Brush Block C-40151  
Brush Block Assembly  
C-40521 or C-40660

# FAA-PMA Approved General Aviation Brake Components Application Guide



FAA-PMA Approved Brake Discs, Linings, Rivets, Pressure Plates and Assemblies, Shim Insulators, Wear Pads, Drive Keys Grease Seals and Mounting Pins

Replacements for Cleveland and McCauley Wheel and Brake Assemblies

Section 1: Type Certified Aircraft

Section 2: Kit Planes

Section 3: Experimental Aircraft

Section 4: Float Plane Brakes

Section 5: McCauley & Cessna Brake Disc Comparison Guide

Section 6: Brake Component Cross Reference

For reference only. For installation eligibility refer to the FAA-PMA Supplement.

Some aircraft models or particular serial numbers may have applications other than those listed in this guide.

Consult the appropriate aircraft parts catalogue, maintenance manual or equipment list when selecting a part for installation.

To convert an original equipment part number to a RAPCO part number, add RA to the beginning of the number.

***RAPCO, inc.***

***REPLACEMENT AIRCRAFT PARTS CO.***

445 Cardinal Lane

Hartland, Wisconsin 53029 USA

For a list of Distributors, please click on the document on the home screen or visit [www.rapcoinc.com](http://www.rapcoinc.com)





**RAPCO INC. FAA-PMA Approved Replacement Parts for Cleveland and McCauley Wheel and Brake Assemblies**

Brake: Disc, Linings, Rivets, Mounting Pins, Overhaul Kits, Wear Pads, Pressure Plates, Shim Insulators, Drive Keys, Grease Seals

This Application Guide is to be used for reference only.

When selecting a part for installation consult the aircraft manufacturer's approved parts catalogue.

RAPCO part numbers are identified by an RA or RAP added to the beginning of the original equipment part number.

[Refer to the FAA-PMA Supplement for installation eligibility.](#)

**Sections:**

Section 1: Type Certificated Aircraft

Section 2: Kit Planes

Section 3: Experimental Aircraft

Section 4: Float Plane Brakes

Section 5: McCauley Brake Disc Cross Reference and Comparison Guides

Section 6: McCauley Brake Disc Dimensions

**Section 1:**

**Type Certificated Aircraft**

Manufacturer Model	Year / Serial Number Notes	Conv/Mod Kit #	Wheel Assembly	Brake Disc	Brake Assembly	Lining	Linings Per Wheel	Rivet or Mounting Pin	Shim Insulators	Pressure Plate	Grease Seal
<b>Aero Commander / Rockwell / Gulfstream / Twin Commander</b>											
100-180 Lark	Conversion Kit 6.00-6	199-188	40-86A	RA164-02000	30-56F	RA066-10500	2	RA105-00200		RA063-01200	
500, 5500A, 500B, 500S, 500U, Aero Commander	Conversion Kit, 8.50-10	199-122	40-198	RA164-22000	30-159B	RA066-09000	8	RA105-00200 RA177-01600	RA068-03300		
	Conversion Kit, 8.50-10	199-122A	40-198	RA164-22000	30-159C	RA066-09000	8	RA105-00200 RA177-01600	RA068-03300		
560F, 680F, 680FL, 680FL(P), 680T, 680V, 680W, 681, 685, 690, 690A, 690B, 690C, 690D, 695, 685A, 695B	Conversion Kit, 8.50-10	199-80	40-107A	RA164-07200	30-107E	RA066-09000	8	RA105-00200 RA177-01600	RA068-03300		
	Conversion Kit, 8.50-10	199-80A	40-107A	RA164-07200	30-107D	RA066-09000	8	RA105-00200 RA177-01600	RA068-03300		
690B, 690C, 695, 695A, 840, 980, 1000	1980 and on		40-107A	RA164-07200	30-107 30-107B 30-107A 30-107, B, C 30-107A, D	RA066-09000	8	RA105-00200 RA177-01600	RA068-03300		
700			40-128C	RA164-05006	30-93A	RA066-02200	6	RA177-00300			
<b>Aerospatiale - see Daher</b>											
<b>Aerofab - see Lake</b>											
<b>Aermacchi - see Siah Marchetti</b>											
<b>Aerostar / Ted Smith Aerostar / Piper Aerostar</b>											
600, 601, 601P, 602P, 700P, PA-60-600, 600A, -601B PA-60-601P, -602P, -700P	171 and on 1975 and on		40-124	RA164-05006	30-88	RA066-02200	8	RA177-00300	RA068-01700		RA154-03000
<b>Agusta / Caproni Vizzola - also see Siah Marchetti</b>											
C22J			40-151	RA164-08500	30-133 30-164	RA066-10500 RA066-06200	2 2	RA105-00200 RA177-00300			
<b>Agusta Westland / Leonardo-Finmeccanica</b>											
AW169			40-481	RA164-21000	30-290, 30-321	RA066-09100 (PP) RA066-09100 (BP)	1 1		RA068-04100		
<b>Air Tractor</b>											
AT-300	8.50-10 Tire		40-101	RA164-03006	30-67X	RA066-10800	4	RA105-00200			
AT-301, -302, -302A, AT-400A	8.50-10 Tire		40-101	RA164-03006	30-89	RA066-10800	6	RA105-00200		RA063-01300	
AT-400, -402, AT-501, -502, -503, -503A	29x11.00-10 Tire		40-133	RA164-05806	30-98C	RA066-10800	12	RA105-00200		RA063-01300	
AT-401, -401A	Pressure Plate Assy. >		40-234	RA164-05606	30-184	RA066-10800	8	RA105-00200		RA063-02500 RA073-02600	
AT-602			40-403	RA164-22202	30-231	RA066-06600	12	RA177-01600	RA068-01600		
AT-802, -802A			40-279	RA164-23000	30-210	RA066-13100	16	RA105-06700			
			40-279A	RA164-23001	30-210	RA066-13100	16	RA105-06700			
			40-279A	RA164-23002	30-210A	RA066-13100	16	RA105-06700			
<b>Allied Ag Cat / Grumman</b>											
G164 Ag Cat	1 thru 399, 8.50-6		40-47		30-32C	RA066-10600	4	RA105-00200	RA068-01100		
	1 thru 399, 8.50-10		40-101	RA164-03006	30-67	RA066-10800	4	RA105-00200			
Super Ag Cat G164B/450	401 and up, 8.50-10		40-101	RA164-03006	30-67	RA066-10800	4	RA105-00200			
			40-101	RA164-03006	30-67E (HD)	RA066-10800	8	RA105-00200			
Super Ag Cat G164A/600 G164B/450	8.50-10 Tire		40-101	RA164-03006	30-67	RA066-10800	4	RA105-00200			
	8.50-10 Tire HD Opt.		40-101	RA164-03006	30-67E (HD)	RA066-10800	8	RA105-00200			
Super Ag Cat G164B/450	660 thru 708, 8.50-10		40-101	RA164-03006	30-67	RA066-10800	4	RA105-00200			
			40-101	RA164-03006	30-67E (HD)	RA066-10800	8	RA105-00200			
	709 and up, 8.50-10		40-101	RA164-03006	30-67E	RA066-10800	8	RA105-00200			
Super Ag Cat G164B/525	8.50-10 Tire		40-101	RA164-03006	30-67	RA066-10800	4	RA105-00200			
			40-101	RA164-03006	30-67E (HD)	RA066-10800	8	RA105-00200			

Note: Please confirm brake assembly number. Part numbers with 'RA' are Rapco products. For Reference ONLY. For installation eligibility see FAA-PMA supplement.



Manufacturer Model	Year / Serial Number Notes	Conv/Mod Kit #	Wheel Assembly	Brake Disc	Brake Assembly	Lining	Linings Per Wheel	Rivet or Mounting Pin	Shim Insulators	Pressure Plate	Grease Seal
Super Ag Cat G164C/600	29x11.00-10 Tire Pressure Plate Assy. >		40-133	RA164-05806	30-84	RA066-10800	8	RA105-00200		RA063-02500 RA073-02600	
Turbo Ag Cat G164D/T G164D/ST G164D/SST	29x11.00-10 Tire Pressure Plate Assy. >		40-133	RA164-05806	30-84	RA066-10800	8	RA105-00200		RA063-02500 RA073-02600	
Ag Cat B-Plus/450, B-Plus/650	8.50-10 Tire		40-101 40-101	RA164-03006 RA164-03006	30-67 30-67E (HD)	RA066-10800 RA066-10800	4 8	RA105-00200 RA105-00200			
Marsh G164C-T Turbo Ag Cat	29x11.00-10 Tire Pressure Plate Assy. >		40-133	RA164-05806	30-84	RA066-10800	8	RA105-00200		RA063-02500 RA073-02600	
Mid Continent King Cat	29x11.00-10 Tire Pressure Plate Assy. >		40-133	RA164-05806	30-84	RA066-10800	8	RA105-00200		RA063-02500 RA073-02600	
G-164B Super B Turbine	8.50-10 Tire		40-101	RA164-03006	30-67E	RA066-10800	8	RA105-00200			
<b>Alon</b> Aircoupe - see Univair											
<b>American Aviation / American General</b> - see Grumman American											
<b>American Champion / Bellanca/ Champion / Aeronca</b>											
7ECA, 7AGCAA Citabria, 7GCBC, 7KCBA, 7SRS	1964 and on		40-28D	RA164-00500	30-19A	RA066-10600	2	RA105-00200			
7ACA Champ	Thru 1970		40-28D	RA164-00500	30-19A	RA066-10600	2	RA105-00200			
	1971 and on		40-78B	RA164-01700	30-9	RA066-10600	2	RA105-00200			
8GCBC Scout	8.50-6 Tire		40-47		30-32B	RA066-10600	4	RA105-00200	RA068-01100		
8KAB Decathlon			40-28D	RA164-00500	30-19A	RA066-10600	2	RA105-00200			
T-250 Aries			40-75G	RA164-01501	30-52S	RA066-10600	4	RA105-00200		RA063-01100	
<b>Arctic Aircraft</b>											
S1B2 Artic Tern	001 - 1021 1022 and on		40-2B 40-86B	RA164-00500 RA164-02000	30-18 30-55	RA066-10600 RA066-10500	2 2	RA105-00200 RA105-00200		RA063-01200	RA154-03000
<b>Aviat / Pitts / Christen / Sky Int.</b>											
S-1S, S-1T Pitts Special S-2, S-2A, S-2B, S-2B			40-78B	RA164-01700	30-9	RA066-10600	2	RA105-00200			
A-1 Husky			40-60	RA164-06700	30-60, -60A	RA066-10600	4	RA105-00200			
<b>Avions Pierre Robin / CADB / APEX</b>											
140,160				RA164-03601	30-52T	RA066-10500	4	RA105-00200		RA063-01100	
DR400 Series			40-97D	RA164-02801	30-63E	RA066-10500	2	RA105-00200		RA063-01200	
HR100/120, 200				RA164-02601	30-63D, -63E	RA066-10500	2	RA105-00200		RA063-01200	
HR100/200, 210				RA164-03601	30-52N	RA066-10500	4	RA105-00200		RA063-01100	
DR400 Series				N/A	30-52T	RA066-10500	4	RA105-00200		RA063-01100	
R1000 Series				N/A	30-63E	RA066-10500	2	RA105-00200		RA063-01200	
R2000 Series				N/A	30-63E	RA066-10500	2	RA105-00200		RA063-01200	
R3000 Series				N/A	30-63E	RA066-10500	2	RA105-00200		RA063-01200	
<b>Ayres</b>											
S2R (Thrush)	29x11-10	199-68A	40-133	RA164-05806	30-98A	RA066-10800	6	RA105-00200		RA063-01300	
S2R-600 Thrush	1939R thru 217R Pressure Plate Assy. > 2173R thru 2529R Pressure Plate Assy. > 2530R and on		40-129 (HD) 40-129 40-133 (HD) 40-133	RA164-05806 RA164-05806 RA164-05806 RA164-05806	30-94 (HD) 30-94 30-98D (HD) 30-98D	RA066-10800 RA066-10800 RA066-10800 RA066-10800	8 8 12 12	RA105-00200 RA105-00200 RA105-00200 RA105-00200		RA063-02500 RA073-02600 RA063-02500 RA073-02600 RA063-01300 RA063-01300	
S2R-660 Turbo Thrush			40-403	RA164-22202	30-231	RA066-06600	12	RA177-01600	RA068-01600		
S2R-800	500R thru 5082R Pressure Plate Assy. > 5083R and on		40-129 (HD) 40-133	RA164-05806 RA164-05806	30-94 (HD) 30-98	RA066-10800 RA066-10800	12 12	RA105-00200 RA105-00200		RA063-02500 RA073-02600 RA063-01300	
S2R-PLZ600 S2R-R1340 S2R-1820 S2R-T11			40-133	RA164-05806	30-98D	RA066-10800	12	RA105-00200		RA063-01300	
S2R-T15	T15-001 T15-002 and on		40-133 40-133	RA164-05806 RA164-05806	30-98 30-98D	RA066-10800 RA066-10800	12 12	RA105-00200 RA105-00200		RA063-01300 RA063-01300	
S2R-T34	6000 thru 6023 6024 and on		40-133 40-133	RA164-05806 RA164-05806	30-98 30-98D	RA066-10800 RA066-10800	12 12	RA105-00200 RA105-00200		RA063-01300 RA063-01300	
S2R-T41 S2R-T65 S2R-T65HG	T41-089 and -090		40-133	RA164-05806	30-98D	RA066-10800	12	RA105-00200		RA063-01300	
<b>Beech / Beechcraft / Raytheon / Hawker Beechcraft / Textron</b>											
D18C, D18S, E18S, E18S-9700, H18, G18S, C45G, TC-45G, RC-45J, C-45H, TC-45H, TC45J, JRB-6, 3N, 3NM, 3TM	Conversion Kit, 8.50-10 Volpar Conversion Kit, 11.00-12	199-127 199-141	40-170 40-21101	RA164-20900 RA164-22400	30-144B 30-170	RA066-09000 RA066-10000	8 8	RA105-00200 RA177-01600 RA105-00200 RA177-01600	RA068-03300 RA068-04600		
45 (TY-34), A45 (T-34A-34A, B-45), D45 (T-34B)	Conversion Kit, 6.50-8	199-50	40-98	RA164-02706	30-66	RA066-04400	4	RA177-00300	RA068-01700		
19, 19A, B19, A-23, 23, A23, A23A, B23, C23, A23-24, A24 A24R	Conversion Kit, 6.00-6 MB-1 thru MB-521 M-2 thru M-1361 MA-1 thru MA-268 MC-2 thru MC-97	199-124	40-113C	RA164-04300	30-75B	RA066-10500	2	RA105-00200		RA063-01200	
23, 24 Musketeer, B19, C33, 24R Sierra, Sport, Sundowner	1971 and on 1974 to 1977 1978 and on		40-113C 40-113C 40-59	RA164-04300 RA164-04300 RA164-06900	30-79A 30-75B 30-59	RA066-10500 RA066-10500 RA066-11200	2 2 2	RA105-00200 RA105-00200 RA105-00200		RA063-01200 RA063-01200	

Note: Please confirm brake assembly number. Part numbers with 'RA' are Rapco products. For Reference ONLY. For installation eligibility see FAA-PMA supplement.



Manufacturer Model	Year / Serial Number Notes	Conv/Mod Kit #	Wheel Assembly	Brake Disc	Brake Assembly	Lining	Linings Per Wheel	Rivet or Mounting Pin	Shim Insulators	Pressure Plate	Grease Seal
Debonair 35-33, 35-A33, 35-B33, 35-C33, 35-C33A,	Conversion Kit, 6.00-6 or 7.00-6 Tire	199-49	40-83	RA164-02504	30-54	RA066-10500	4	RA105-00200		RA063-01100	
Bonanza E33A, F33, F33A, F33C											
35-33, 35-A33, 35-B33, 35-C33, 35-C33A E33A, F33, F33A, F33C	Conversion Kit, 6.00-6	199-124	40-113C	RA164-04300	30-75B	RA066-10500	2	RA105-00200		RA063-01200	
33, A33 B33	CD-1 thru CD-387 CD-388 thru CD-639		40-1 40-37	RA164-00900 RA164-00700	30-1 30-24	RA066-11100 RA066-10600	2 4	RA105-00200 RA105-00200			
F33A	CD-1272 thru CD-1304 CJ-31 thru CJ-124		40-83	RA164-02504	30-54	RA066-10500	4	RA105-00200		RA063-01100	
F33C, F33A, F33C	CE-301 thru CE-634		40-83	RA164-02504	30-54	RA066-10500	4	RA105-00200		RA063-01100	
F33A, F33C	CE-635 thru CE-1071 CJ-125 thru CJ-155 CE-1072 and on CJ-156 and on		40-83A	RA164-02505	30-54A	RA066-10500	4	RA105-00200		RA063-01100	
F33A, F33C			40-83A	RA164-02505	30-54C	RA066-10500	4	RA105-00200		RA063-01100	
T34C Mentor			40-111A	RA164-06506	30-74B	RA066-06700	4	RA177-00300			
Bonanza 35, A35, B35, C35, D35, E35, F35, G35 H35, J35, K35, M35, N35, P35, 35R, S35, V35, V35A, V35B	Conversion Kit, 6.00-6 or 7.00-6 Tire	199-49	40-83	RA164-02504	30-54	RA066-10500	4	RA105-00200		RA063-01100	
35, A35, B35, C35, D35, E35, F35, G35, 35R, H35, J35, K35, M35, N35, P35, S35	Conversion Kit, 6.50-8	199-50	40-98	RA164-02706	30-66	RA066-04400	4	RA177-00300	RA068-01700		
35, A35, B35, D35, E35, F35, G35, 35R, G33, H35, J35, K35, M35, N35, P35, S35, V35, V35A, V35B	Conversion Kit, 6.00-6	199-124	40-113C	RA164-04300	30-75B	RA066-10500	2	RA105-00200		RA063-01200	
G33 V35BTC 36 Bonanza	CD-1272 thru CD-1304 CJ-31 thru CJ-124 D-9193 thru D-9861 E-1 thru E-824 D-9862 and on		40-83	RA164-02504	30-54	RA066-10500	4	RA105-00200		RA063-01100	
A36	Conversion Kit, 6.00-6	199-124	40-113C	RA164-04300	30-75B	RA066-10500	2	RA105-00200		RA063-01200	
V35A, A36	Conversion Kit, 6.00-6 or 7.00-6 Tire	199-49	40-83	RA164-02504	30-54	RA066-10500	4	RA105-00200		RA063-01100	
A36 A36, A36TC	E-825 thru E-1802 E-1803 thru E-2254 EA-1 thru EA-186 EA-187 thru EA-442		40-83A 40-83B	RA164-02505 RA164-02505	30-54A 30-54A	RA066-10500 RA066-10500	4 4	RA105-00200 RA105-00200		RA063-01100 RA063-01100	RA154-03000
A36, B36TC	E-2255 and on EA-443 and on		40-83B	RA164-02505	30-54C	RA066-10500	4	RA105-00200		RA063-01100	RA154-03000
Travel Air 95, B95, B95A, D95A, E95, Baron, 95-55, 95-A55, 95-B55, 95-B55A, 95-B55B, 95-C55, 95-C55A, D55, D55A, E55, E55A	Conversion Kit, 6.50-8	199-50	40-98	RA164-02706	30-66	RA066-04400	8	RA177-00300	RA068-01700		RA154-03000
Twin Bonanza 50, B50, C50, D50, D50A, D50B, D50C, D50E, E50, F50, G50, H50, J50 Baron, B55, E55	Conversion Kit, 8.50-10 Twin Bonanza Excalibur 1978, Heavy Duty Opt. 1979 and on Heavy Duty Option	199-88	40-134A 40-128 40-98G 40-128D	RA164-06306 RA164-06106 RA164-02706 RA164-06106	30-99 30-93B 30-66G 30-93C	RA066-06600 RA066-04400 RA066-09700 RA066-09700	8 6 4 6	RA177-01600 RA177-00300 RA177-00300 RA177-00300			RA154-03000 RA154-03000 RA154-03000 RA154-03000
Travel Air 95, B95, B95A, D95A, E95, Baron, 95-55, 95-A55, 95-B55, 95-B55A, 95-B55B, 95-C55, 95-C55A, Baron D55, D55A, E55, E55A, 58, 58A	Conversion Kit 6.50-8 19.5x6.75-8 Tire	199-138	40-128D	RA164-06106	30-93C	RA066-09700	6	RA177-00300	RA068-02700		RA154-03000
C55 D55 E55 56TC Baron A56TC	TE-1 and on TE-452 and on TE-768 and on TG-1 thru TG-63 TG-84 and on		40-98 40-98	RA164-02706 RA164-02706	30-66 30-66A	RA066-04400 RA066-02200	4 4	RA177-00300 RA177-00300	RA068-01700 RA068-01700		
58 Baron	1978, Heavy Duty Opt. 1979 and on Heavy Duty		40-128 40-98G 40-128D	RA164-06106 RA164-02706 RA164-06106	30-93B 30-66G 30-93C	RA066-04400 RA066-09700 RA066-09700	6 4 6	RA177-00300 RA177-00300 RA177-00300	RA068-02700 RA068-01700 RA068-02700		RA154-03000 RA154-03000 RA154-03000
58	TH-1 and on		40-98	RA164-02706	30-66	RA066-04400	4	RA177-00300	RA068-01700		
58TC	1984 and on		40-171	RA164-20806	30-145	RA066-09700	6	RA177-00300	RA068-02700		RA154-03000
58P	1984 and on		40-171	RA164-20806	30-145	RA066-09700	6	RA177-00300	RA068-02700		RA154-03000
58P, 58TC, 60, A60, B60 B60 Duke	Conversion Kit 1984 and on	199-73	40-128 40-171	RA164-06106 RA164-20806	30-93 30-145	RA066-04400 RA066-09700	6 6	RA177-00300 RA177-00300	RA068-02700 RA068-02700		RA154-03000
Queen Air 65, A65, 70, 65-80, 65-A80, 65-B80, 65-88	Conversion Kit 6.50-8 19.5x6.75-8 Tire	199-123	40-170B	RA164-22900	30-144A	RA066-09000	8	RA105-00200 RA177-01600	RA068-03300		
76 Dutchess 77 Skipper			40-83 40-59	RA164-02504 RA164-06900	30-54B 30-59D	RA066-10500 RA066-11200	4 2	RA105-00200 RA105-00200		RA063-01100	
King Air 65-90, 65-A90, 65-A90-1, (JU-21A), 65-A90-4 (RU-21E, RU-21H), B90, C90, C90A, C90GT, C90GTI, E90, H90 (T-44A), F90, 99, 99A, A99A, B99, C99	Conversion Kit, 8.50-10	199-90	40-170A	RA164-20900	30-144	RA066-09000	8	RA105-00200 RA177-01600	RA068-03300		
King Air F90, 99, 99A, A99A, B99, C99, 100, A100, B100 KingAir, 200, 200C, 200CT, 200T King Air, A200, A200C, A200CT, B200, B200C, B200CT, B200T, B200GT, B200CGT	Conversion Kit, 18x5.5	199-110	40-289	RA164-21000	30-146	RA066-09100 RA066-09200	2 2		RA068-04100		
King Air F90, 99, 99A, A99A, B99, C99, 100, A100 (U-21F), B100, 200, 200C, 200CT, 200T King Air, B200, B200C, B200C (C-12F, B200C (C-R12), B200C (UC-12F), B22C(UC-12M) B200CGT, B200CT, B200GT, B200T	High Flotation Gear Conversion Kit 6.50-10, 22 x 6.75-10	199-125	40-203		30-162	RA109-00200 Wear Pad	10 Per Brake				

Note: Please confirm brake assembly number. Part numbers with 'RA' are Rapco products. For Reference ONLY. For installation eligibility see FAA-PMA supplement.



Manufacturer Model	Year / Serial Number Notes	Conv/Mod Kit #	Wheel Assembly	Brake Disc	Brake Assembly	Lining	Linings Per Wheel	Rivet or Mounting Pin	Shim Insulators	Pressure Plate	Grease Seal
1900, 1900C, 1900C (C-12J), 1900D	Conversion Kit 6.50-10, 22 x 6.75-10	199-184 199-220	40-273A		30-204 30-204A	RA109-00201 Wear Pad	70 Per Brake		RA105-06700 For PP and BP		
T34C Mentor			40-111A	RA164-06506	30-74B	RA066-06700	4	RA177-00300			
<b>Bell Helicopter</b>											
230, 430	Key Drive RA205-02900		40-276								RA154-03000
<b>Bellanca</b>											
17-30A, 17-31A, 17-31ATC, 300A, Viking			40-75E	RA164-01501	30-52M	RA066-10500	4	RA105-00200		RA063-01100	
T-250 Aires			40-75G	RA164-01501	30-52S	RA066-10500	4	RA105-00200		RA063-01100	
<b>Bombardier - see, de Havilland</b>											
<b>Britten-Norman / Britten-Norman Group / Pilatus Britten-Norman / International Aviation</b>											
BN-2, BN-2A Islander, BN-2B-20, -21, -26, -27, BN-2T	1969 thru 1979		40-90	RA164-02201	30-23A	RA066-06500 (PP) RA066-06200 (BP)	2 2	RA177-00300 RA177-00300	RA068-01100	RA063-01100	
	1979 and on		40-90B	RA164-02201	30-23A, -22C	RA066-06500 (PP) RA066-06200 (BP)	2 2	RA177-00300 RA177-00300	RA068-01100	RA063-01100	
BN-2A-2, -3, -6, -8, -9, -20, -21, -27, BN2B-20, -21, -26, -27	All, with 7.00-6 Tire		40-90F	RA164-01506	30-23D	RA066-06500 (PP) RA066-06200 (BP)	2 2	RA177-00300 RA177-00300	RA068-01100	RA063-01100	
BN-2A MK111, Trilander, BN-2A MK111-2, BN-2A MK111-3			40-98F	RA164-02706	30-66H	RA066-02200	4	RA177-00300	RA068-01700		
Defender 4000			40-128E		30-93E	RA066-04400	6	RA105-00300			
<b>Cessna / Textron</b>											
<b>120, 140</b>											
120, 140 120, 140, 140A	8004 thru 13399, 6.00-6 13400 & up, 6.00-6	199-46	40-97A	RA164-02601	30-63A	RA066-10500	2	RA105-00200		RA063-01200	
<b>150, 152 with Cleveland Brakes</b>											
150A, B	1961 to 1962, 5.00-5 150-59119 thru 150-59700		40-12	RA164-00400	30-9	RA066-10600	2	RA105-00200			
150C	1963 with 5.00-5 6.00-6 Tire		40-19 40-57	RA164-00400 RA164-00500	30-9 30-40	RA066-10600 RA066-10600	2 2	RA105-00200 RA105-00200			
150D, E	1964 to 1965, 5.00-5 6.00-6 Tire		40-78 40-79A	RA164-01700 RA164-01600	30-9 30-40	RA066-10600 RA066-10600	2 2	RA105-00200 RA105-00200			
150F, G, F150F, G (Reims)	1966 to 1967		40-97, 40-97A	RA164-02601	30-63, -63A	RA066-10500	2	RA105-00200		RA063-01200	
150H, J, K F150H, J A150K Aerobat	1968 to 1970 1970		40-97A	RA164-02601	30-63A	RA066-10500	2	RA105-00200		RA063-01200	
150L A150L F150K FA150K, L FRA150L 152 A152 F152, FA152	1971 and on 1971 and on 1970 and on 1970 to 1971 1972 and on 1978 and on 1978 and on 1978 and on		40-113	RA164-04000	30-75	RA066-10500	2	RA105-00200		RA063-01200	
<b>150, 152, with McCauley Brakes - also see Comparison Guide in Section 4.</b>											
150, A150	1971 to 1973		D-30063	N/A	C-30018	RA066-30026	2	RA105-00200		RA063-30025	
F150, F152	1973 to 1976		D-30260	RA164-30195	C-30018	RA066-30026	2	RA105-00200		RA063-30025	
152	1976		D-30580	RA164-30195	C-30018-4	RA066-30026	2	RA105-00200		RA063-30025	
FA152 (Reims)	1976 to 1977		D-30291-6	RA164-30440	C-30018-4	RA066-30026	2	RA105-00200		RA063-30025	
	1977		D-30660-1	RA164-30615-1	C-30018-5	RA066-30026	2	RA105-00200		RA063-30025	
	1978 to 1981		D-30660-1	RA164-30615-1	C-30018-5	RA066-30026	2	RA105-00200		RA063-30025	
	1982 and on		D-30660-1	RA164-30615-1	C-30764-5	RA066-30026	2	RA105-00200		RA063-30025	
<b>162</b>											
162 SkyCatcher			40-308	RA164-01700	30-308	RA066-14800*	2	RA105-00200			
<b>170</b>											
170, 170A, 170B	Conversion Kit, 6.00-6	199-46	40-97A	RA164-02601	30-63A	RA066-10500	2	RA105-00200		RA063-01200	
<b>172 with Cleveland Brakes</b>											
172, 172A thru 172E Skyhawk, P172D	Conversion Kit, 6.00-6	199-46	40-97A	RA164-02601	30-63A	RA066-10500	2	RA105-00200		RA063-01200	
172F	172-51823 thru 172-52808		40-97A	RA164-02601	30-56, -63A	RA066-10500	2	RA105-00200		RA063-01200	
172F, G, H	172-52809 thru 172-56512		40-97A	RA164-02601	30-63, -63A	RA066-10500	2	RA105-00200		RA063-01200	
172I, K	172-56513 thru 172-59223		40-97A	RA164-02601	30-63A	RA066-10500	2	RA105-00200		RA063-01200	
172L thru 172S	1971 and on 172-59224 and on		40-113	RA164-04000	30-75A	RA066-10500	2	RA105-00200		RA063-01200	
F172F, G	F172-0096 thru F172-0204		40-97A	RA164-02601	30-56, -63A	RA066-10500	2	RA105-00200		RA063-01200	
172G, H	F172-0205 thru F172-00754		40-97A	RA164-02601	30-63A	RA066-10500	2	RA105-00200		RA063-01200	
F172K	172-00755 and on		40-113	RA164-04000	30-75A	RA066-10500	2	RA105-00200		RA063-01200	
F172RG Cutlass	172-RG0001 and on		40-113	RA164-04000	30-75	RA066-10500	2	RA105-00200		RA063-01200	
<b>172 with McCauley Brakes - also see Comparison Guide in Section 4.</b>											
172, R172	1971 to 1973 (3 - 1/4")		D-30063	N/A	C-30018-2	RA066-30026	2	RA105-00200		RA063-30025	
F172 (Reims)	1973 to 1976		D-30260	RA164-30195	C-30018-2	RA066-30026	2	RA105-00200		RA063-30025	
FR172 (Reims)	1976 (6 - 5/16" Bolts)		D-30580	RA164-30195	C-30018-2	RA066-30026	2	RA105-00200		RA063-30025	
	1977 (3 - 1/4" Bolts)		D-30600-1	N/A	C-30018-6	RA066-30026	2	RA105-00200		RA063-30025	
	1978 to 1981		D-30660-1	RA164-30615-1	C-30018-6	RA066-30026	2	RA105-00200		RA063-30025	
	1982 and on		D-30660-1	RA164-30615-1	C-30764-6	RA066-30026	2	RA105-00200		RA063-30025	

Note: Please confirm brake assembly number. Part numbers with 'RA' are Rapco products. For Reference ONLY. For installation eligibility see FAA-PMA supplement.  
\* RA066-14800 Not for installation on USTC aircraft



Manufacturer Model	Year / Serial Number Notes	Conv/Mod Kit #	Wheel Assembly	Brake Disc	Brake Assembly	Lining	Linings Per Wheel	Rivet or Mounting Pin	Shim Insulators	Pressure Plate	Grease Seal
172RG Outlass	1980 to 1981 1982 and on		D-30660-1	RA164-30615-1	C-30018-6	RA066-30026	2	RA105-00200		RA063-30025	
<b>175</b>											
175, 175A, 175B, 175C Skylark	Conversion Kit, 6.00-6	199-46	40-97A	RA164-02601	30-63A	RA066-10500	2	RA105-00200		RA063-01200	
<b>177 with Cleveland Brakes</b>											
177 A, B Cardinal	177-01165 thru 177-01530		40-97A	RA164-02601	30-63, -63A	RA066-10500	2	RA105-00200		RA063-01200	
177B	177-01531		40-113	RA164-04000	30-75	RA066-10500	2	RA105-00200		RA063-01200	
177A, B	177-1165 and on		40-113	RA164-04000	30-75	RA066-10500	2	RA105-00200		RA063-01200	
177RG, F177RG, 177, 177RG, F177RG	1971 to 1974		40-113	RA164-04000	30-75	RA066-10500	2	RA105-00200		RA063-01200	
<b>177 with McCauley Brakes - also see Comparison Guide in Section 4.</b>											
177RG, F177RG	1975		D-30580	RA164-30195	C-30018-4	RA066-30026	4	RA105-00200		RA063-30025	
177, 177RG	1976		D-30291-6	RA164-30440	C-30018-4	RA066-30026	4	RA105-00200		RA063-30025	
F177RG (Reims)	1977		D-30600-1	N/A	C-30018-5	RA066-30026	4	RA105-00200		RA063-30025	
	1978 and on		D-30660-1	RA164-30615-1							
<b>180 with Cleveland Brakes</b>											
180, 180A, thru 180F Skywagon	Conversion Kit, 6.00-6	199-46	40-97A	RA164-02601	30-63A	RA066-10500	2	RA105-00200		RA063-01200	
180, 180A thru 180H, 180J, 180K	Conversion Kit, 8.00-6	199-62	40-75D	RA164-03601	30-52N	RA066-10500	4	RA105-00200		RA063-01100	
180, 180A, thru 180F, 180H, 180J	Conversion Kit, 6.00-6	199-60	40-75B	RA164-01501	30-52	RA066-10500	4	RA105-00200		RA063-01100	
180G	180-51313 and on		40-75B	RA164-01501	30-52	RA066-10500	4	RA105-00200		RA063-01100	
180H	180-52011 thru 180-52195		40-75D	RA164-03601	30-52D	RA066-10500	4	RA105-00200		RA063-01100	
180H	180-52196 and on		40-75D	RA164-03601	30-52N	RA066-10500	4	RA105-00200		RA063-01100	
180H	180-51775 thru 189-51993		40-66	RA164-00700	30-21	RA066-10600	4	RA105-00200			
<b>180 with McCauley Brakes - also see Comparison Guide in Section 4.</b>											
180 Series Skywagon	1973 to 1974		D-30063-1	N/A	C-30018-1, -2	RA066-30026	2	RA105-00200		RA063-30025	
	1974		D-30291-3	RA164-30414	C-30018-5, -6	RA066-30026	4	RA105-00200		RA063-30025	
	1974 to 1978		D-30063-4	N/A	C-30018-5, -6	RA066-30026	4	RA105-00200		RA063-30025	
	1978 and on		D-30291-1	RA164-30388	C-30018-5, -6	RA066-30026	4	RA105-00200		RA063-30025	
			D-30660-2	RA164-30615-2	C-30018-5, -6	RA066-30026	4	RA105-00200		RA063-30025	
<b>182 with Cleveland Brakes</b>											
182, 182A thru 182G Skylane	Conversion Kit, 6.00-6	199-46	40-97A	RA164-02601	30-63A	RA066-10500	2	RA105-00200		RA063-01200	
182G thru N	182-55059 thru 182-60445		40-97A	RA164-02601	30-56A	RA066-10500	2	RA105-00200		RA063-01200	
182N, 182P, 182Q	182-60446 thru 182-67715		40-113	RA164-04000	30-75	RA066-10500	2	RA105-00200		RA063-01200	
R182, TR182, FR182 (Reims)	1978 and on		40-75B	RA164-01501	30-52U	RA066-10500	4	RA105-00200		RA063-01100	
182S, 182T, T182T	1996 and on		40-75B	RA164-01501	30-52U	RA066-10500	4	RA105-00200		RA063-01100	
<b>182 with McCauley Brakes - also see Comparison Guide in Section 4.</b>											
182 Series	1976		D-30291-6	RA164-30440	C-30018-4	RA066-30026	4	RA105-00200		RA063-30025	
F182 (Reims)	1977		D-30600-1	N/A	C-30018-5	RA066-30026	4	RA105-00200		RA063-30025	
	1978 to 1980		D-30660-1	RA164-30615-1	C-30018-5	RA066-30026	4	RA105-00200		RA063-30025	
R182, TR182, FR182 (Reims)	1978 and on		D-30660-3	RA164-30615-3	C-30018-3, -4	RA066-30026	4	RA105-00200		RA063-30025	
T182	1981 and on		D-30660-3	RA164-30615-3	C-30018-3, -4	RA066-30026	4	RA105-00200		RA063-30025	
<b>185 with Cleveland Brakes</b>											
185, 185A thru 185E, A185E, A185F	Conversion Kit, 8.00-6	199-62	40-75D	RA164-03601	30-52N	RA066-10500	4	RA105-00200		RA063-01100	
185, 185A 185B, A185E, A185F	Conversion Kit, 6.00-6	199-60	40-75T	RA164-08300	30-52N	RA066-10500	4	RA105-00200		RA063-01100	
185, 185A	185-0001 thru 185-0512		40-75B	RA164-01501	30-52	RA066-10500	4	RA105-00200		RA063-01100	
185B	185-00513 thru 185-0653		40-32	RA164-00700	30-21	RA066-10600	4	RA105-00200			
185C, D, E	185-0054 thru 185-1095		40-66	RA164-00700	30-21	RA066-10600	4	RA105-00200			
A185E, F	185-1096 and on		40-75B	RA164-01501	30-52	RA066-10500	4	RA105-00200		RA063-01100	
A185E, F	185-1471 and on		40-75D	RA164-03601	30-52D	RA066-10500	4	RA105-00200		RA063-01100	
A185E	185-1150 thru 185-1447		40-66	RA164-00700	30-21	RA066-10600	4	RA105-00200			
<b>185 with McCauley Brakes - also see Comparison Guide in Section 4.</b>											
185 Series Skywagon	1973 to 1974		D-30063-1	N/A	C-30018-1, -2	RA066-30026	2	RA105-00200		RA063-30025	
	1974		D-30291-3	RA164-30414	C-30018-5, -6	RA066-30026	4	RA105-00200		RA063-30025	
	1974 to 1978		D-30063-4	N/A	C-30018-5, -6	RA066-30026	4	RA105-00200		RA063-30025	
	1978 and on		D-30291-1	RA164-30388	C-30018-5, -6	RA066-30026	4	RA105-00200		RA063-30025	
			D-30660-2	RA164-30615-2	C-30018-5, -6	RA066-30026	4	RA105-00200		RA063-30025	
<b>188</b>											
188, A188, 188A Agwagon	1966 to 1972		40-75B	RA164-01501	30-52B	RA066-10500	4	RA105-00200		RA063-01100	
A188A, 188B, A188B, T188C	8.50-10 Tire 8.50-10 Tire 22 x 8.00-8 Tire		40-101A 40-101 40-98A	RA164-03106 RA164-03006 RA164-02707	30-67A 30-67C 30-66A	RA066-10800 RA066-10800 RA066-11000	4 4 4	RA105-00200 RA105-00200 RA105-00200			
<b>190, 195</b>											
190, 195, 195A, 195B	Conversion Kit, 6.50-10	199-61	40-40C	RA164-00806	30-28C	RA066-03300	6	RA177-00400	RA068-01600		
<b>205</b>											
205	205-0001 thru 205-0480		40-67	RA164-00700	30-35	RA066-10600	4	RA105-00200	RA068-01100		
205A Stationair	205-0481 to 205-0577		40-75B	RA164-01501	30-52	RA066-10500	4	RA105-00200		RA063-01100	
<b>206 with Cleveland Brakes</b>											
206, P206, U206, U206F, U206G, TU206E, TU206F, TU206G, Super Skywagon, Stationair	Conversion Kit, 8.00-6	199-62	40-75D	RA164-03601	30-52N	RA066-10500	4	RA105-00200		RA063-01100	
206E, 206F, TU206E, TU206F	Conversion Kit, 8.00-6	199-62A	40-75T	RA164-08300	30-52N	RA066-10500	4	RA105-00200		RA063-01100	
	Conversion Kit, 6.00-6	199-60	40-75B	RA164-01501	30-52	RA066-10500	4	RA105-00200		RA063-01100	

Note: Please confirm brake assembly number. Part numbers with 'RA' are Rapco products. For Reference ONLY. For installation eligibility see FAA-PMA supplement.



Manufacturer Model	Year / Serial Number Notes	Conv/Mod Kit #	Wheel Assembly	Brake Disc	Brake Assembly	Lining	Linings Per Wheel	Rivet or Mounting Pin	Shim Insulators	Pressure Plate	Grease Seal
206	206-0001 thru 206-0275		40-75B	RA164-01501	30-52	RA066-10500	4	RA105-00200		RA063-01100	
U206	U206-0276 thru U206-1256		40-75B	RA164-01501	30-52	RA066-10500	4	RA105-00200		RA063-01100	
	U206-1257 and on 8.00-6 tire		40-75D	RA164-03601	30-52N	RA066-10500	4	RA105-00200		RA063-01100	
P206, Super Skylane	P206-001 thru P206-0566		40-75B	RA164-01501	30-52	RA066-10500	4	RA105-00200		RA063-01100	
	U206-0567 and on 8.00-6 tire		40-75D	RA164-03601	30-52N	RA066-10500	4	RA105-00200		RA063-01100	
206H, T206H, Stationair	1996 and on		40-75B	RA164-01501	30-52U	RA066-10500	4	RA105-00200		RA063-01100	
	8.00-6 tire		40-75T	RA164-08300	30-52W	RA066-10500	4	RA105-00200		RA063-01100	
<b>206 with McCauley Brakes - also see Comparison Guide in Section 4.</b>											
206 Series	1974		D-30063-2	N/A	C-30018-3, -4	RA066-30026	4	RA105-00200		RA063-30025	
	1974 to 1978		D-30291-2	RA164-30398	C-30018-3, -4	RA066-30026	4	RA105-00200		RA063-30025	
	1978 and on		D-30660-3	RA164-30615-3	C-30018-3, -4	RA066-30026	4	RA105-00200		RA063-30025	
	1974		D-30063-4	N/A	C-30018-5, -6	RA066-30026	4	RA105-00200		RA063-30025	
	1974 to 1978, 8.00-6		D-30291-1	RA164-30388	C-30018-5, -6	RA066-30026	4	RA105-00200		RA063-30025	
	1978 and on, 8.00-6		D-30660-2	RA164-30615-2	C-30018-5, -6	RA066-30026	4	RA105-00200		RA063-30025	
<b>207 with Cleveland Brakes</b>											
207 Series, Skywagon, Stationair 7, 8	207-00001 and on		40-75B	RA164-01501	30-52F	RA066-10500	4	RA105-00200		RA063-01100	
	8.00-6 tire		40-75D	RA164-03601	30-52E	RA066-10500	4	RA105-00200		RA063-01100	
<b>208</b>											
208 Caravan 1	1 thru 138		40-179	RA164-22201	30-163	RA066-03300	8	RA177-00300	RA068-02800	RA063-02500 RA073-08500 RA073-08502	RA154-03000
	Pressure Plate Assy. > Pressure Plate Assy. >										
	139 and on		40-179	RA164-22201	30-182	RA066-03300	8	RA177-00300	RA068-02800	RA063-02500 RA073-08500 RA073-08502	RA154-03000
	Pressure Plate Assy. > Pressure Plate Assy. >										
	139 and on w/upgrade	199-281	40-179	RA164-22201	30-182A	RA066-15300	8	RA177-00300	RA068-02800	RA063-02500 RA073-08500 RA073-08502	RA154-03000
	Pressure Plate Assy. > Pressure Plate Assy. >										
208B	1 thru 53		40-179	RA164-22201	30-163	RA066-03300	8	RA177-00300	RA068-02800	RA063-02500 RA073-08500 RA073-08502	RA154-03000
	Pressure Plate Assy. > Pressure Plate Assy. >										
	54 and on		40-179	RA164-22201	30-182	RA066-03300	8	RA177-00300	RA068-02800	RA063-02500 RA073-08500 RA073-08502	RA154-03000
	Pressure Plate Assy. > Pressure Plate Assy. >										
	139 and on w/upgrade	199-281	40-179	RA164-22201	30-182A	RA066-15300	8	RA177-00300	RA068-02800	RA063-02500 RA073-08500 RA073-08502	RA154-03000
	Pressure Plate Assy. > Pressure Plate Assy. >										
<b>210 with Cleveland Brakes</b>											
210, 210A, 210B, 210C, Centurian 210K, 210L, 210M	Conversion Kit, 6.00-6	199-60	40-75B	RA164-01501	30-52	RA066-10500	4	RA105-00200		RA063-01100	
210C	210-58086 thru 210-58220		40-21	RA164-00900	30-45	RA066-11100	2	RA105-00200			
210D thru M	210-58221 thru 210-62954		40-75B	RA164-01501	30-52	RA066-10500	4	RA105-00200		RA063-01100	
T210F, T210K, T210L, T210M, T210N	T210-0001 and on										
P210N	Conversion Kit, 6.00-6 P21000001 thru P21000150	199-60A	40-75B	RA164-01501	30-52U	RA066-10500	4	RA105-00200		RA063-01100	
P210	1984		40-142	RA164-07800	30-127C	RA066-06200	4	RA177-00300	RA068-01100	RA063-01100	
210N	210-62955 and on		40-775B	RA164-01501	30-52V	RA066-10500	4	RA105-00200		RA063-01100	
P210N	1979 and on										
<b>210 with McCauley Brakes - also see McCauley Disc Comparison Guide in Section 4.</b>											
210 Series	1974		D-30063-2	N/A	D-301118-3, -4	RA066-30026	4	RA105-00200		RA063-30025	
	1974 to 1978		D-30291-2	RA164-30398	D-301118-3, -4	RA066-30026	4	RA105-00200		RA063-30025	
	1978 and on		D-30660-3	RA164-30615-3	D-301118-3, -4	RA066-30026	4	RA105-00200		RA063-30025	
<b>350 / 400 Corvalls</b>											
350 Corvalls (LC42-550FG)			40-406A		30-233A	RA066-06200	4	RA177-00300	RA068-01100	RA063-01100	
400 Corvalls (LC41-550FG)			40-406A		30-233A	RA066-06200	4	RA177-00300	RA068-01100	RA063-01100	
<b>300 Series Multi Engine</b>											
303, T303 Crusader	1982 and on		40-142	RA164-07800	30-127A	RA066-06200	4	RA177-00300	RA068-01100	RA063-01100	
	6.80-8 Tire		40-98H	RA164-08406	30-66F	RA066-04400	4	RA177-00300	RA068-01700		
305A, B, C, D, E, F	1951 and on		40-97E	RA164-02601	30-63K	RA066-10500	2	RA105-00200		RA063-01200	
USAF O-1A, -1E, -1G			40-75F	RA164-01501	30-52L	RA066-10500	4	RA105-00200		RA063-01100	
310, 310A thru 310H, E310H, 310I, 310J, 310J-1, E310J, 310K, 310L, 310N, 310P, T310P, 310Q, T310Q, 310R, T310R	Conversion Kit, 6.50-10	199-64	40-40B	RA164-01406	30-28D	RA066-03300	6	RA177-00400	RA068-01600		RA154-03000
310 Series	1976 to 1981		40-40A	RA164-00806	30-28B	RA066-03300	6	RA177-00400	RA068-01600		RA154-03000
	1981 and on		40-40D	RA164-20206	30-28B	RA066-03300	6	RA177-00400	RA068-01600		RA154-03000
320, 320-1, 320A, 320B, 320C, Skynight 320D, 320E, 320F	Conversion Kit, 6.50-10	199-64	40-40B	RA164-01406	30-28D	RA066-03300	6	RA177-00400	RA068-01600		
335	1979 and on		40-40A	RA164-00806	30-28B	RA066-03300	6	RA177-00400	RA068-01600		RA154-03000
336 Skymaster	336-0001 thru 336-0098		40-67A	RA164-02504	30-61	RA066-10500	4	RA105-00200	RA068-01100	RA063-01100	
	336-009 and on		40-75B	RA164-01501	30-52	RA066-10500	4	RA105-00200		RA063-01100	
337, 337A (USAF 02B) Skymaster	1965 to 1966 337-0001 thru 337-0525		40-96A, 40-96E	RA164-02504	30-61	RA066-10500	4	RA105-00200		RA063-01100	
337B	1967 337-0526 thru 337-0619		40-96A, 40-96E	RA164-02504	30-61D	RA066-10500	4	RA105-00200	RA068-01100	RA063-01100	

Note: Please confirm brake assembly number. Part numbers with 'RA' are Rapco products. For Reference ONLY. For installation eligibility see FAA-PMA supplement.



Manufacturer Model	Year / Serial Number Notes	Conv/Mod Kit #	Wheel Assembly	Brake Disc	Brake Assembly	Lining	Linings Per Wheel	Rivet or Mounting Pin	Shim Insulators	Pressure Plate	Grease Seal
337 B thru D	337-0620 thru 337-1193		40-96A, 40-96E	RA164-02504	30-61D	RA066-10500	4	RA105-00200	RA068-01100	RA063-01100	
337E	337-01194 and on		40-98A	RA164-02707	30-69B	RA066-02200	4	RA177-00300	RA068-01700		
340 Series	1972 to 1981		40-40A	RA164-00806	30-28B	RA066-03300	6	RA177-00400	RA068-01600		RA154-03000
	1981 and on		40-40D	RA164-20206	30-28B	RA066-03300	6	RA177-00400	RA068-01600		RA154-03000
340, 340A	Conversion Kit, 6.50-10, Heavy Duty	199-72	40-135	RA164-06406	30-100	RA066-06600	8	RA177-01600	RA068-03100		RA154-03000
340, 340A	Conversion Kit, 6.50-10	199-76	40-135A	RA164-20306	30-100	RA66-06600	8	RA177-01600	RA068-03100		RA154-03000
<b>400 Series Multi Engine</b>											
401, 401A, 401B, 402, 402A, 402B, 411, 411A, 414	Conversion Kit, 6.50-10, Heavy Duty	199-72	40-135	RA164-06406	30-100	RA066-06600	8	RA177-01600	RA068-03100		RA154-03000
401, 401A, 401B, 402, 402A, 402B, 402C, 411, 411A, 421, 421A, 421B, 421C	Conversion Kit, 6.50-10	199-76	40-135A	RA164-20306	30-100	RA066-06600	8	RA177-01600	RA068-03100		RA154-03000
401 Series			40-40A	RA164-00806	30-28B	RA066-03300	6	RA177-00400	RA068-01600		RA154-03000
402 Series	1/4" Bolts		40-135	RA164-06406	30-100	RA066-06600	8	RA177-01600	RA068-03100		RA154-03000
	1981 and on, 5/16" Bolts		40-135A	RA164-20306	30-100	RA066-06600	8	RA177-01600	RA068-03100		RA154-03000
404 Titan	404-00001 and on		40-132	RA164-09100	30-97	RA066-06400	8	RA177-01600	RA068-02900		
411, 411A	1965 to 1968		40-40A	RA164-00806	30-28B	RA066-03300	6	RA177-00400	RA068-01600		RA154-03000
414 Chancellor			40-40A	RA164-00806	30-28B	RA066-03300	6	RA177-00400	RA068-01600		RA154-03000
414A	1981 and on, 1/4" Bolts		40-135	RA164-06406	30-100	RA066-06600	8	RA177-01600	RA068-03100		RA154-03000
	5/16" Bolt		40-135A	RA164-20306	30-100	RA066-06600	8	RA177-01600	RA068-03100		RA154-03000
421C Golden Eagle	1976 to 1980, 1/4" Bolts		40-135	RA164-06406	30-100	RA066-06600	8	RA177-01600	RA068-03100		RA154-03000
	1981 and on, 5/16" Bolts		40-135A	RA164-20306	30-100	RA066-06600	8	RA177-01600	RA068-03100		RA154-03000
425 Corsair	425-0001 and on		40-138	RA164-05500	30-113	RA066-06400	8	RA177-01600	RA068-02900		
			40-138A	RA164-05500	30-113A	RA066-06400	8	RA177-01600	RA068-02900		
441	Conversion Kit 22x7.75-10 tire	199-115	40-169	RA164-20700	30-143	RA066-07300	8	RA177-01600			
LC42-550FG / LC41-550FG - see 350 / 400 Corvalls											
<b>Champion</b> - see American Champion											
<b>Cirrus</b>											
SR-20			40-414	RA164-24400	30-239	RA066-14100	2	RA105-00200			
SR-20	1601 and on		40-75P	RA164-01501	30-52A, -52B	RA066-10500	4	RA105-00200		RA063-01100	
SR-22			40-75P	RA164-01501	30-52	RA066-10500	4	RA105-00200		RA063-01100	
SR-22	Upgrade or 1740 and on		40-406		30-233B	RA066-06200	4	RA177-00300	RA068-01100	RA063-01100	
<b>Classic</b>											
YMF-5 Waco	F5001 and on		40-223	RA164-03106	30-176	RA066-10800	4	RA105-00200			
<b>Columbia</b>											
300, 350, 400			40-406A	RA164-02504	30-233A	RA066-06200	4	RA177-00300	RA068-01100	RA063-01100	
<b>Commander</b> - see Grumman American or Rockwell International /CPC											
<b>Croplease</b> - see NDN Aircraft											
<b>Daher / Aerospatiale / Socata</b>											
100, 110, 125, 150, 180 Series, Rallye			40-97D	RA164-02601	30-63J	RA066-10500	2	RA105-00200		RA063-01200	
110ST Galopin, 160ST Garnement, 180T Gairien, 180GT Galliard			40-97D	RA164-02601	30-63J	RA066-10500	2	RA105-00200		RA063-01200	
220, 235 Series, 235G Guerrier (Rallye), 235GT Gabrier, 235CA Gaucho			40-84, 40-84B	RA164-01900	30-41B	RA066-10600	4	RA105-00200			
TB9 Tampico, TB10 Tobago, TB200			40-97E, 40-97F	RA164-02601	30-63J	RA066-10500	2	RA105-00200		RA063-01200	
TB20, 21 Trinidad			40-84, 40-84B	RA164-01900	30-41B	RA066-10600	4	RA105-00200			
TB30 Epsilon			40-90B	RA164-02201	30-23B	RA066-06500 (pp) RA066-06200 (bp)	2 2	RA177-00300 RA177-00300			
TBM 700	1 thru 204 206 thru 239 241 thru 243 Drive Key RA205-02900		40-270		30-191	RA109-01500 Wear Pad	10 Per Brake				
	205, 240, 244 and up Drive Key RA205-02900		40-434		30-191	RA109-01500 Wear Pad	10 Per Brake				
TBM 850	All		40-434		30-191	RA109-01500	10				
TBM 700, TBM 850	Drive Key RA205-02900										
<b>Daimler Benz</b> - see Messerschmitt											
<b>de Havilland / Bombardier / Viking Air Limited</b>											
Chipmunk DHC-1-21, -22, -22A	Conversion Kit, 6.00-6	199-79	40-97D	RA164-02601	30-63P	RA066-10500	2	RA105-00200		RA063-01200	
DHC-1B-2-S3, -S5											
DHC-2 Mk.I, Mk.II, Mk.III Beaver	Conversion Kit, 8.50-10	199-95	40-134	RA164-06306	30-99	RA066-10600	8	RA105-00200	RA068-02800		
DHC-6-1, -100, -200, 300 Twin Otter	Conversion Kit, 11.00-12	199-92	40-21101	RA164-22400	30-170	RA066-10000	8	RA105-00200 RA177-01600	RA068-04600		

Note: Please confirm brake assembly number. Part numbers with 'RA' are Rapco products. For Reference ONLY. For installation eligibility see FAA-PMA supplement.



Manufacturer Model	Year / Serial Number Notes	Conv/Mod Kit #	Wheel Assembly	Brake Disc	Brake Assembly	Lining	Linings Per Wheel	Rivet or Mounting Pin	Shim Insulators	Pressure Plate	Grease Seal
<b>Diamond</b>											
DA20-AC, DA20-C1, Katana			40-78E	RA164-24200	30-9D	RA066-10600	2	RA105-00200			
DA40, DA40F			40-414A	RA164-24400	30-239A	RA066-14100	2	RA105-00200			RA154-03000
DA42, DA42 NG, DA42 M-NG, Twin Star			40-75Z	RA164-01501	30-52Z	RA066-10500	4	RA105-00200		RA063-01100	
Edgley - see Lavaux											
ERCO Ercoupe - see Univair											
<b>Emair</b>											
MA-1B Diablo 1200	1978 and on		40-139		30-111	RA066-10800	8	RA105-00200		RA063-02500 RA073-02600	
Fairchild - see Swearingen											
<b>FFA Flugzeugwerke Altenhein AG</b>											
AS202-18A4 Bravo	224 and on		40-97A	RA164-02601	30-63A	RA066-10500	2	RA105-00200		RA063-01200	
Fletcher - see Pacific Aerospace											
Forney Aircoupe - see Univair											
<b>Found Brothers</b>											
100 Centennial			40-75B	RA164-01501	30-52	RA066-10500	4	RA105-00200		RA063-01100	
<b>GAF - (Australia) / Nomad</b>											
N22B, N22S			40-75T	RA164-08300	30-52Q	RA066-10500	4	RA105-00200		RA063-01100	
N24A Nomad	Heavy Duty		40-143	RA164-08200	30-129	RA066-06200	4	RA177-00300	RA068-01100	RA063-01100	
<b>General Avia (Italy)</b>											
F.20, F.201TP, Pegaso			40-75G	RA164-01501	30-52P	RA066-10500	4	RA105-00200		RA063-01100	
F.22, Pinguino			40-151	RA164-08500	30-164	RA066-06200	2	RA177-00300		RA063-01200	
F.1300			40-131	RA164-05700	30-96	RA066-06200	2	RA177-00300	RA068-01100	RA063-01100	
<b>Gippsland</b>											
GA8			40-75T	RA164-08300	30-52N	RA066-10500	4	RA105-00200		RA063-01100	
<b>Globe / Swift / TEMCO</b>											
GC1A, GC1B	Conversion Kit, 6.00-6	199-48	40-113C	RA164-04300	30-79B	RA066-10500	2	RA105-00200		RA063-01200	
<b>Great Lakes</b>											
2T-1A, 2T-1A-1, 2T-1A-2			40-113	RA164-04000	30-75	RA066-10500	2	RA105-00200		RA063-01200	
<b>Grob / Grob Werke GMBH</b>											
G103, G103C			40-97A	RA164-02601	30-63A	RA066-10500	2	RA105-00200		RA063-01200	
G109 Series			40-78B	RA164-01700	30-9	RA066-10600	2	RA105-00200			
G115, -A, -B, -C			40-78B	RA164-01700	30-9	RA066-10600	2	RA105-00200			
G115-T			40-84	RA164-01900	30-41B	RA066-10600	4	RA105-00200			
G115-TA			40-84	RA164-01900	30-41B	RA066-10600	4	RA105-00200			
Grumman - see Grumman American or Ag Cat											
<b>Grumman American (Gulfstream) American General, Commander- also see Rockwell International / True Flight Holdings</b>											
AA-1, -1A, -1B, TR-2 Yankee / Trainer	All models thru 1974		40-86A	RA164-02000	30-55B	RA066-10500	2	RA105-00200		RA063-01200	
	1975 and on		40-88C	RA164-02000	30-56B	RA066-10500	2	RA105-00200		RA063-01200	
AA-5 Traveler	All models thru 1974		40-86A	RA164-02000	30-55B	RA066-10500	2	RA105-00200		RA063-01200	
AA-5A, -5B Cheetah / Tiger	1975 and on		40-88C	RA164-02000	30-56B	RA066-10500	2	RA105-00200		RA063-01200	
GA-7 Cougar			40-90	RA164-02201	30-23B	RA066-06500 (PP) RA066-06200 (BP)	2 2	RA177-00300 RA177-00300	RA068-02800		
Gulfstream - see Grumman American or Aero Commander											
Hawker Beechcraft - see Beech											
<b>Helio</b>											
H-250, H-295, H391, H-395 Courier			40-75E	RA164-01501	30-52A	RA066-10500	4	RA105-00200		RA063-01100	
			40-75D	RA164-03601	30-52N	RA066-10500	4	RA105-00200		RA063-01100	
			40-75T	RA164-08300	30-52N	RA066-10500	4	RA105-00200		RA063-01100	
	6.50-8 Tire		40-98A	RA164-02707	30-66A	RA066-11000	4	RA105-00200	RA068-01700		
Industeia Unidas SA (Mexico)											
A-9B Sparrow / Quail			40-99	RA164-02800	30-41, -41B	RA066-10600	4	RA105-00200			
International Aviation (see Britten Norman)											
<b>KAI) Korea Aerospace Industries</b>											
KT-1 Woongbi	Drive Key PN: RA205-02900										
<b>Lake / Aerofab / Revo</b>											
LA-4	1963 and on		40-113X	RA164-04000	30-75X	RA066-10500	2	RA105-00200		RA063-01200	
			40-74, 40-74B	RA164-00700	30-51, -51B	RA066-10600	4	RA105-00200			
	Heavy duty option		40-418		30-241	RA066-10500	4	RA105-00200		RA063-01100	

Note: Please confirm brake assembly number. Part numbers with 'RA' are Rapco products. For Reference ONLY. For installation eligibility see FAA-PMA supplement.



Manufacturer Model	Year / Serial Number Notes	Conv/Mod Kit #	Wheel Assembly	Brake Disc	Brake Assembly	Lining	Lirings Per Wheel	Rivet or Mounting Pin	Shim Insulators	Pressure Plate	Grease Seal
LA-180, LA-200 Buccaneer Amphibian	1974 1975 1977 and on Heavy duty option		40-113X	RA164-04000	30-75X	RA066-10500	2	RA105-00200		RA063-01200	
			40-74A	RA164-00700	30-51, -51B	RA066-10600	4	RA105-00200			
			40-74B	RA164-00700	30-51, -51B	RA066-10600	4	RA105-00200			
			40-74B	RA164-00700	30-51B	RA066-10600	4	RA105-00200			
			40-418		30-241	RA066-10500	4	RA105-00200		RA063-01100	
LA-250 Renegade			40-74B	RA164-00700	30-51B	RA066-10600	4	RA105-00200			
	Option		40-418		30-241	RA066-10500	4	RA105-00200		RA063-01100	
LA-270 Turbo Renegade	with McCauley		D-30660-7		D-30793-4	RA066-30026	4	RA105-00200			
	with Cleveland		40-418		30-241	RA066-10500	4	RA105-00200		RA063-01100	
<b>LAVIASA</b> - see Piper PA-25-Series											
<b>Leonardo-Finmeccanica</b> - see Agusta Westland											
<b>Lovaux</b> - Edgley											
EA7 Optica	1 and on		40-86	RA164-02000	30-55	RA066-10500	2	RA105-00200		RA063-01200	
<b>Marsh Aviation</b>											
S2R-T			40-129	RA164-05606	30-94	RA066-10800	8	RA105-00200			
	29 x 11.00-10		40-133	RA164-05606	30-98	RA066-10800	12	RA105-00200		RA063-01300	
G-164C-T			40-133	RA164-05606	30-94	RA066-10800	8	RA105-00200			
<b>Maule</b>											
M4 Series Jetasan / Rocket			40-97D	RA164-02601	30-63E	RA066-10500	2	RA105-00200		RA063-01200	
M5, M6 Series			40-97D	RA164-02601	30-63E	RA066-10500	2	RA105-00200		RA063-01200	
M7 Series Star Rocket	Heavy Duty Option		40-75D	RA164-03601	30-52N	RA066-10500	4	RA105-00200		RA063-01100	
M9 Series			40-75D	RA164-03601	30-52AC	RA066-10500	4	RA105-00200		RA063-01100	
MXT-7-180											RA154-03000
<b>M.B.B.</b> - Dimler Benz see Messerschmitt											
<b>McCulloch</b>											
J2 Helicopter			40-78B	RA164-01700	30-9	RA066-10600	2	RA105-00200			
<b>Messerschmitt / Dimler Benz / Bolkow - Blohm GmbH / Airbus Defence and Space</b>											
B.O.-208			40-12	RA164-00400	30-9	RA066-10600	2	RA105-00200			
B.O.-209-150FF Monson, B.O.-209-150FV & RV, B.O.-209-160FV & RV			40-78B	RA164-01700	30-9	RA066-10600	2	RA105-00200			
<b>Mitsubishi</b>											
MU-2B, MU-2B-10, -15, -20, -25, -26, -26A, -30, -35, -36, -36A, -40, -60	Conversion Kit, 8.50-10	199-101	40-148	RA164-07200	30-131	RA066-09000	8	RA105-00200 RA177-01600	RA068-03300		
<b>Mooney</b>											
M10 Cadet/Coupe (see Univair)											
M20A, M20B, Mark 20, M20C, M20D, Master, M20E Super 21	1401 thru 3466 101 thru 260 101 thru 1308		40-24	RA164-00900	30-5	RA066-11100	2	RA105-00200			
M20C, Mark 21, Ranger, M20E, Super 21	670001 & on 670001 & on		40-86	RA164-02000	30-56A, -56D	RA066-10500	2	RA105-00200		RA063-01200	
M20F Executive 21 M20G Statesman	660003 & on 680001 & on										
M20J, 201, M20K, (231 Turbo, 252TSE)	24-0001 & on 25-0001 & on										
M20M	All S/N		40-90A	RA164-02300	30-65	RA066-10500	4	RA105-00200		RA063-01100	
<b>M7 Aerospace</b> - see Swearingen											
<b>Navion</b>											
Navion A, B, D, E, F, G, H											RA154-03000
<b>NDN Aircraft Ltd. / Crolease PLC.</b>											
NDN6 Fieldmaster	* Disc Experimental Only		40-175	RA164-21100*	30-149	RA066-06600	12	RA177-01600	RA068-01600		
<b>The New Piper Aircraft, Inc.</b> - see Piper											
<b>New Zealand Aerospace Ind.</b> - see Pacific Aerospace Corp.											
<b>North American</b>											
T-28 Trojan (Non type certificated)	Conversion Kit 6.50-B 19.5x6.75-8 Tire	199-123	40-170B	RA164-22900	30-144A	RA066-09000	8	RA105-00200 RA177-01600			
<b>North American Rockwell</b> - see Aero Commander or Rockwell											
<b>Pacific Aerospace Corp., LTD / New Zealand Aerospace Ind. / Fletcher</b>											
FU24 Fletcher FU24-950 FU24-954 FU24A-954	1978 and on		40-47		30-32C	RA066-10600	4		RA068-01100		
08-600 Cresco			40-101	RA164-03006	30-89E	RA066-10800	6	RA105-00200		RA063-01300	
CT/4E Airliner	S/N 200 and on		40-97F	RA164-02601	30-63S	RA066-10500	4	RA105-00200		RA063-01200	
DT4			40-97F	RA164-02601	30-63S	RA066-10500	4	RA105-00200		RA063-01200	

Note: Please confirm brake assembly number. Part numbers with 'RA' are Rapco products. For Reference ONLY. For installation eligibility see FAA-PMA supplement.



Manufacturer Model	Year / Serial Number Notes	Conv/Mod Kit #	Wheel Assembly	Brake Disc	Brake Assembly	Lining	Linings Per Wheel	Rivet or Mounting Pin	Shim Insulators	Pressure Plate	Grease Seal
PAC 750XL	Pressure Plate Assy. > Pressure Plate Assy. >		40-179A	RA164-03006	30-182	RA066-10800	8	RA105-00200	RA068-02800	RA063-02500 RA073-08500 RA073-08502	RA154-03000
	Lining upgrade Pressure Plate Assy. > Pressure Plate Assy. >	199-281	40-179A	RA164-03006	30-182A	RA066-15300	8	RA177-00300	RA068-02800	RA063-02500 RA073-08500 RA073-08502	RA154-03000
<b>Partenavia</b> - see Vulcanair or G.A.F.											
<b>Pilatus Aircraft Ltd</b>											
PC-12/47E PC-12, PC-12/45, PC-12/47, PC-12/47E	1231 thru 1257, 1258 on. With Cleveland Conv. OH Kit PN: RA199-575A Drive Key RA205-05201	199-276	40-424	RA159-07400 (Rotor Disc)	30-244	RA109-03000 (Wear Pad)	72	RA105-08701 & RA105-02401		RA063-08400 RA073-10100 Stationary Disc RA232-03500 RA242-01800	
<b>Pilatus Britten-Norman</b> - see Britten Norman											
<b>Piper / The New Piper Aircraft</b>											
J-3 Cub	Univair STC		40-60	RA164-06700	30-60, -60A	RA066-10600	4	RA105-00200			
PA-11 Cub Special	Univair STC		40-60	RA164-06700	30-60, -60A	RA066-10600	4	RA105-00200			
PA-12 Super Cruiser	Univair STC	199-231	40-60	RA164-06700	30-60, -60A	RA066-10600	4	RA105-00200			
PA-14 Family Cruiser	Univair STC		40-60	RA164-06700	30-60, -60A	RA066-10600	4	RA105-00200			
PA-16 Clipper	Univair STC		40-60	RA164-06700	30-60, -60A	RA066-10600	4	RA105-00200			
PA-18-150 Super Cub, PA-18A-150 Super Cub	18-7609137 & on		40-60	RA164-06700	30-60, -60A, -60B	RA066-10600	4	RA105-00200			
PA-18 Super Cub	Univair STC		40-60	RA164-06700	30-60, -60A	RA066-10600	4	RA105-00200			
PA-18 Super Cub	1.5" axles. Univair STC	199-231	40-84	RA164-01900	30-41, -41B	RA066-10600	4	RA105-00200			
PA-20 Piper Cub	Univair STC		40-60	RA164-06700	30-60, -60A	RA066-10600	4	RA105-00200			
PA-20 Piper Cub	1.5" axles. Univair STC	199-231	40-84	RA164-01900	30-41, -41B	RA066-10600	4	RA105-00200			
PA-20/22 Piper Cub	1.5" axles. Univair STC	199-231	40-84	RA164-01900	30-41, -41B	RA066-10600	4	RA105-00200			
PA-22-108 Colt			40-28	RA164-00500	30-18	RA066-10600	2	RA105-00200			
PA-22-125, -135, -150, -160	Univair STC SA91AL	199-276	40-28	RA164-00500	30-18	RA066-10600	2	RA105-00200			
PA-20/22 Piper Cub	1.5" axles. Univair STC	199-231	40-84	RA164-01900	30-41, -41B	RA066-10600	4	RA105-00200			
PA-23-150 Apache			3080A	-	3000-500	RA066-10600	4	RA105-00200			RA154-03000
PA-23-160 Apache			3080A	-	3000-500	RA066-10600	4	RA105-00200			RA154-03000
PA-23-235 Apache	27-1 thru 27-3737		3080B	RA164-00206	37-200-2	RA066-10600	8	RA105-00200	RA068-01100		
PA-23 Series Aztec	Conversion Kit, 7.00-6	199-63	40-131	RA164-05700	30-96	RA066-06200	8	RA177-00300	RA068-01100	RA063-01100	
PA-23-250 Aztec	27-3738 thru 27-7554137, 27-7554139, 27-7554141 thru 27-7554149 27-7554138		3080D	RA164-03206	37-200A	RA066-06500 (PP) RA066-06200 (BP)	4 4	RA177-00300 RA177-00300			RA154-03000
PA-24-180Comanche SB7100	24-1 thru 24-3295		3070 (40-5)	RA164-00900	3000-250	RA066-10600	4	RA105-00200			
PA-24-250 Comanche SB7100	24-3296 thru 24-3306		3070 (40-5)	RA164-00900	30-41, -41B	RA066-10600	4	RA105-00200			RA154-03000
PA-24-260 Comanche SB7100	24-3307 and on		40-58	RA164-00900	30-41, -41B	RA066-10600	4	RA105-00200			RA154-03000
			40-84	RA164-01900	30-41B	RA066-10600	4	RA105-00200			
PA-24-400 Comanche	24-130 and on		40-90	RA164-02201	30-23	RA066-06500 (PP) RA066-06200 (BP)	2 2	RA177-00300 RA177-00300	RA068-02800		RA154-03000
PA-25-235, Pawnee w/SB7100	25-1 thru 25-1999		3070 (40-5)	RA164-00900	3000-250	RA066-10600	4	RA105-00200			
PA-25-235	25-2000 thru 25-2136		40-61	RA164-01300	3000-250	RA066-10600	4	RA105-00200			
PA-25-235B	25-2137 thru 25-4171		40-61	RA164-01300	30-41, -41B	RA066-10600	4	RA105-00200			
PA-25-235C, D	25-4172 thru 25-7656119		40-84A	RA164-03300	30-41B	RA066-10600	4	RA105-00200			
PA-25-260C, D	25-7656120 and on		40-84A	RA164-03300	30-41B	RA066-10600	4	RA105-00200			
PA-28-140 Cherokee/Crusier	28-20002 thru 28-20520		40-28	RA164-00500	30-18	RA066-10500	2	RA105-00200			
	28-20521 and on		40-86	RA164-02000	30-55	RA066-10500	2	RA105-00200		RA063-01200	
	1974 and on		40-86B	RA164-02000	30-55	RA066-10500	2	RA105-00200		RA063-01200	RA154-03000
PA-28-150 Chreokee	28-1 thru 28-1760		40-28	RA164-00500	30-18	RA066-10600	2	RA105-00200			
	28-1761 and on		40-86	RA164-02000	30-55	RA066-10500	2	RA105-00200		RA063-01200	
PA-28-151 Cherokee/Warrior	All, 1974 and on		40-86B	RA164-02000	30-55	RA066-10500	2	RA105-00200		RA063-01200	RA154-03000
PA-28-160 Chreokee	28-1 thru 28-1760		40-28	RA164-00500	30-18	RA066-10600	2	RA105-00200			
	28-1761 and on		40-86	RA164-02000	30-55	RA066-10500	2	RA105-00200		RA063-01200	
PA-28-161 Cherokee/ Warrior II	7716001 and on		40-86B	RA164-02000	30-55	RA066-10500	2	RA105-00200		RA063-01200	RA154-03000
PA-28-180 Cherokee/Archer	28-1 thru 28-1760		40-28	RA164-00500	30-18	RA066-10600	2	RA105-00200			
	28-1761 and on		40-86	RA164-02000	30-55	RA066-10500	2	RA105-00200		RA063-01200	
	1974 and on		40-86B	RA164-02000	30-55	RA066-10500	2	RA105-00200		RA063-01200	RA154-03000
PA-28-181 Cherokee/Archer II	28-7690001 and on		40-86B	RA164-02000	30-55	RA066-10500	2	RA105-00200		RA063-01200	RA154-03000
PA-28-235 Cherokee 235/Pathfinder	28-10003 thru 28-10486 28-10487 and on		40-58, 40-86, 40-86B	RA164-00900 RA164-02000 RA164-02000	30-34 30-55 30-55	RA066-11100 RA066-10500 RA066-10500	2 2 2	RA105-00200 RA105-00200 RA105-00200		RA063-01200 RA063-01200 RA063-01200	RA154-03000
PA-28-236 Dakota	28-7911001 and on 28-7911001 and on, HD		40-86B 40-90A	RA164-02000 RA164-02300	30-55 30-65	RA066-10500 RA066-10500	2 4	RA105-00200 RA105-00200		RA063-01200 RA063-01100	RA154-03000
PA-28R-180 Cherokee/Arrow 180	28R-30005 thru 28R-7130005 28R-7130006 and on		40-84 40-86	RA164-01900 RA164-02000	30-41, -41B 30-55	RA066-10600 RA066-10500	4 2	RA105-00200 RA105-00200		RA063-01200 RA063-01200	
	1974 and on		40-86B	RA164-02000	30-55	RA066-10500	2	RA105-00200		RA063-01200	
	1977 and on		40-86B	RA164-02000	30-55	RA066-10500	2	RA105-00200		RA063-01200	
PA-28R-200 Cherokee/Arrow 200	28R-35001 thru 28R-7135109 28R-7135110 and on		40-84 40-86	RA164-01900 RA164-02000	30-41, -41B 30-55	RA066-10600 RA066-10500	2 2	RA105-00200 RA105-00200		RA063-01200 RA063-01200	
	1974 and on		40-86B	RA164-02000	30-55	RA066-10500	2	RA105-00200		RA063-01200	
	1977 and on		40-86B	RA164-02000	30-55	RA066-10500	2	RA105-00200		RA063-01200	

Note: Please confirm brake assembly number. Part numbers with 'RA' are Rapco products. For Reference ONLY. For installation eligibility see FAA-PMA supplement.



Manufacturer Model	Year / Serial Number Notes	Conv/Mod Kit #	Wheel Assembly	Brake Disc	Brake Assembly	Lining	Linings Per Wheel	Rivet or Mounting Pin	Shim Insulators	Pressure Plate	Grease Seal
PA-28-201T, PA-28R-201, PA-28RT-201, PA-28R-201T			40-86B	RA164-02000	30-55	RA066-10500	2	RA105-00200		RA063-01200	
PA-30 Twin Comanche	30-2 thru 30-845		40-34	RA164-01000	30-23	RA066-06500 (PP) RA066-06200 (BP)	2 2	RA177-00300 RA177-00300	RA068-01100		RA154-03000
	30-845 and on		40-90	RA164-02201	30-23	RA066-06500 (PP) RA066-06200 (BP)	2 2	RA177-00300 RA177-00300	RA068-01100		
Twin Comanche Also see PA-39											
PA-31, PA-31-300, PA-31-325, PA31-350	Conversion Kit, 6.50-10	199-100	40-16Z	RA164-07700	30-138	RA066-06800	6	RA177-01600	RA068-03000		RA154-03000
PA-31-300 Navajo	31-5 thru		40-102	RA164-03506	30-68	RA066-03300	6	RA177-00400	RA068-01600		RA154-03000
PA-31-310 Navajo	31-7300962										
PA-31-310, PA-31-325, PA31-350	Conversion Kit, 6.50-10	199-66	40-130	RA164-07906	30-95A	RA066-06600	8	RA177-01600	RA068-02800		RA154-03000
PA-31-325 Navajo C/R	31-7300963 and on		40-102A	RA164-04406	30-68A, -68B	RA066-03300	6	RA177-00400	RA068-01600		RA154-03000
PA-31-350 Chiefcain	31-5001 thru 31-7652075, HD 31-7812001 and on 31-7652076 and on		40-102A 40-130 40-130	RA164-04406 RA164-07906 RA164-07906	30-68A, -68B 30-95A 30-95, -95A	RA066-03300 RA066-06600 RA066-06600	6 8 8	RA177-00400 RA177-01600 RA177-01600	RA068-01600 RA068-02800 RA068-02800		RA154-03000
PA-31-350	Conversion Kit, 6.50-10	199-119	40-195	RA164-21900	30-158	RA066-06800	8	RA177-01600	RA068-03100		RA154-03000
PA-31-350, PA-31P (425 HP)	Conversion Kit, 6.50-10	199-83	40-141	RA164-07700	30-123	RA066-06800	12	RA177-01600	RA068-03000		
T-1020			40-130	RA164-07906	30-95A	RA066-06600	8	RA177-01600	RA068-02800		
	Heavy Duty		40-141	RA164-07700	30-123	RA066-06800	12	RA177-01600	RA068-03000		
PA-31T Cheyenne I, IA, II	31-780015 and on		40-106 40-106A	RA164-03906 RA164-03906	30-106 30-106	RA066-06800 RA066-06800	16 16	RA177-01600 RA177-01600	RA068-03100 RA068-03100		RA154-03000
PA-31T, PA-31T1	Conversion Kit, 6.50-10	199-89	40-106	RA164-03906	30-106	RA066-06800	16	RA177-01600	RA068-03100		RA154-03000
PA-31T2	Conversion Kit, 6.50-10	199-111	40-167	RA164-20600	30-142	RA066-07300	8	RA177-01600	RA068-03900		RA154-03000
T-1040			40-167	RA164-20600	30-142	RA066-07300	8	RA177-01600	RA068-03900		
PA-32-260 Cherokee Six "260"	32-1 and on 1974 and on All / Heavy Duty Option		40-90 40-90A 40-120	RA164-02201 RA164-02300 RA164-21600	30-65 30-65 30-83	RA066-10500 RA066-10500 RA066-06200	4 4 4	RA105-00200 RA105-00200 RA177-00300		RA063-01100 RA063-01100 RA063-01100	RA154-03000 RA154-03000 RA154-03000
PA-32-300 Cherokee Six "300"	32-40000 and on 1974 and on All / Heavy Duty Option		40-90 40-90A 40-120	RA164-02201 RA164-02300 RA164-21600	30-65 30-65 30-83	RA066-10500 RA066-10500 RA066-06200	4 4 4	RA105-00200 RA105-00200 RA177-00300		RA063-01100 RA063-01100 RA063-01100	RA154-03000 RA154-03000 RA154-03000
PA-32R-300 Cherokee/Lance	1976 and on Heavy Duty Option		40-90A 40-120	RA164-02300 RA164-21600	30-65 30-83	RA066-10500 RA066-06200	4 4	RA105-00200 RA177-00300	RA068-01100	RA063-01100 RA063-01100	RA154-03000 RA154-03000
PA-32RT-300 Lance II	7885002 and on Heavy Duty Option		40-90A 40-120	RA164-02300 RA164-21600	30-65 30-83	RA066-10500 RA066-06200	4 4	RA105-00200 RA177-00300	RA068-01100	RA063-01100 RA063-01100	RA154-03000 RA154-03000
PA-32RT-300T Turbo Lance II	7887001 and on Heavy Duty Option		40-90A 40-120	RA164-02300 RA164-21600	30-65 30-83	RA066-10500 RA066-06200	4 4	RA105-00200 RA177-00300	RA068-01100	RA063-01100 RA063-01100	RA154-03000 RA154-03000
PA-32-301, 301T Saratoga and SP Series	Heavy Duty Option		40-90A 40-120C	RA164-02300 RA164-21600	30-65 30-83A	RA066-10500 RA066-06200	4 4	RA105-00200 RA177-00300	RA068-01100	RA063-01100	
PA-34-200 Seneca	7250001 and on 1974 and on Heavy Duty Option		40-90 40-90A 40-120	RA164-02201 RA164-02300 RA164-21600	30-65 30-65 30-83	RA066-10500 RA066-10500 RA066-06200	4 4 4	RA105-00200 RA105-00200 RA177-00300		RA063-01100 RA063-01100 RA063-01100	RA154-03000 RA154-03000 RA154-03000
PA-34-200T Seneca II	7250001 and on Heavy Duty Option		40-90A 40-120	RA164-02300 RA164-21600	30-65 30-83	RA066-10500 RA066-06200	4 4	RA105-00200 RA177-00300	RA068-01100	RA063-01100 RA063-01100	RA154-03000 RA154-03000
PA-34-220T Seneca III, IV			40-90A 40-120C	RA164-02300 RA164-21600	30-65 30-83A	RA066-10500 RA066-06200	4 4	RA105-00200 RA177-00300	RA068-01100	RA063-01100 RA063-01100	RA154-03000 RA154-03000
PA-36 Pawnee Brave			40-101	RA164-03006	30-67B	RA066-10800	4	RA105-00200			
PA-38-112 Tomahawk	5.00-5 Tire 6.00-6 Tire		40-78B 40-59D	RA164-01700 RA164-06900	30-9, 9B 30-53A	RA066-10600 RA066-11200	2 2	RA105-00200 RA105-00200			RA154-03000 RA154-03000
PA-39 Twin Comanche			40-90	RA164-02201	30-23	RA066-06500 (PP) RA066-06200 (BP)	2 2	RA177-00300 RA177-00300			
Twin Comanche Also see PA-30											
PA-42 Cheyenne III, PA-42-720 IIIA	Conversion Kit, 6.50-10	199-112	40-166	RA164-07400	30-141	RA066-07300	8	RA177-01600	RA068-03900		RA154-03000
PA-42-1000 (400LS) Cheyenne IV			40-176		30-150	RA109-00200 Wear Pad	30 Per Brake				RA154-03000
PA-44-180 Seminole	7995001 and on		40-90A 40-120 (HD)	RA164-02300 RA164-21600	30-65 30-83	RA066-10500 RA066-06200	4 4	RA105-00200 RA177-00300	RA068-01100	RA063-01100 RA063-01100	
PA-44-180T	1 and on		40-120 (HD)	RA164-21600	30-83	RA066-06200	4	RA177-00300	RA068-01100	RA063-01100	
PA-46-310P Malibu, -350P Mirage			40-120C	RA164-21600	30-83A	RA066-06200	4	RA177-00300	RA068-01100	RA063-01100	
PA-46-500 Meridian			40-142	RA164-07800	30-127D	RA066-06200	4	RA177-00300	RA068-01100	RA063-01100	
PA-46-500TP Meridian			40-142	RA164-07800	30-127D	RA066-06200	4	RA177-00300	RA068-01100	RA063-01100	
PA-600, -700 Series - see Aerostar											
<b>Pitts - see Aviat</b>											
<b>Quest Aircraft Company</b>											
Kodiak 100	Pressure Plate Assy. > Pressure Plate Assy. > Lining upgrade Pressure Plate Assy. > Pressure Plate Assy. >	199-281	40-179	RA164-22201	30-182	RA066-03300	8	RA177-00300	RA068-02800	RA063-02500 RA073-08500 RA073-08502	RA154-03000
			40-179	RA164-22201	30-182A	RA066-15300	8	RA177-00300	RA068-02800	RA063-02500 RA073-08500 RA073-08502	RA154-03000
<b>RFB Rhein-Flugzeugbau GmbH - Subsidiary of MBB</b>											
RFB 400/600 Fantreiner			40-96E	RA164-2504	30-61E	RA066-10500	4	RA105-00200		RA063-01100	
<b>Raytheon - see Beech</b>											
<b>Republic Seabee - See Stol Aircraft Corp.</b>											
<b>Rockwell International - Also see Grumman American (Single engine), Aero Commander (Twin Engine) or Thrush (Ag. Aircraft) / CPC</b>											
112, 112A, B Alpine	1 thru 495 500 and on		40-113A 40-75H	RA164-04300 RA164-01501	30-79 30-52H	RA066-10500 RA066-10500	2 4	RA105-00200 RA105-00200		RA063-01100	
112TC, 112TCA, 114, 114B Gran Turismo	13000 and on		40-75H	RA164-01501	30-52H	RA066-10500	4	RA105-00200		RA063-01100	

Note: Please confirm brake assembly number. Part numbers with 'RA' are Rapco products. For Reference ONLY. For installation eligibility see FAA-PMA supplement.



Manufacturer Model	Year / Serial Number Notes	Conv/Mod Kit #	Wheel Assembly	Brake Disc	Brake Assembly	Lining	Linings Per Wheel	Rivet or Mounting Pin	Shim Insulators	Pressure Plate	Grease Seal
<b>Saab - USA</b>											
MF1-15, MF1-17 Supporter AC, Mushshak			40-97-D	RA164-02601	30-63D, -63E	RA066-10500	2	RA105-00200		RA063-01200	
<b>Sadler Aircraft Corp.</b>											
A-22 Lasa 18-100 OPV			40-78B	RA164-01700	30-9	RA066-10600	2	RA106-00200			
<b>Schaefer Aircraft Modifications / Embraer - see Piper</b>											
<b>Schleicher</b>											
ASW20, 21, 22, 23 Sailplane			40-78B	RA164-01700	30-9	RA066-10600	2	RA106-00200			
<b>Schweitzer - also see Agcat</b>											
SGS 1-34 Sailplane			OEM	OEM	30-9	RA066-10600	2	RA105-00200			
1-36 Glider			OEM	OEM	30-63D	RA066-10500	2	RA105-00200		RA063-01200	
<b>SIAI-Marchetti</b>											
SF.205			40-97E	RA164-02601	30-63M	RA066-10500	2	RA105-00200		RA063-01200	
SF.260, SF.260C					30-9	RA066-10600	2	RA105-00200			
SF.260SW Sea Warrior			40-90A	RA164-02300	30-65A	RA066-10500	4	RA105-00200		RA063-01100	
SF.600TP			40-75	RA164-01501	30-52P	RA066-10500	2	RA105-00200		RA063-01100	
<b>SiberJet - see Sino Swearingen</b>											
<b>Slingsby Aviation</b>											
T67M260			40-86B, 40-86F	RA164-02000	30-55	RA066-10500	2	RA105-00200		RA063-01200	RA154-03000
T-3A, TR67GRP			40-407	RA164-24400	30-236	RA066-10500	2	RA105-00200		RA063-01200	RA154-03000
<b>Socata - See Daher</b>											
<b>Sportavia / RFB</b>											
RF6C/RS180			40-86A	RA164-02000	30-55B	RA066-10500	2	RA105-00200		RA063-01200	
<b>Stinson - see Univair</b>											
<b>Stol Aircraft Corp. / Republic</b>											
UC-1 Twin Bee	Stol Aircraft Corp. mod		40-74	RA164-00700	30-51A	RA066-10600	4	RA105-00200			
<b>Swearingen Aircraft / Fairchild / SiberJet / M7 Aerospace</b>											
SA26-AT, SA26-T	Conversion Kit, 8.50-10	199-150	40-170	RA164-20900	30-144A	RA066-09000	8	RA105-00200	RA068-03300		
SJ-30	Drive Key PN: RA205-02900		40-259								
<b>Taylorcraft</b>											
F-19 Sportsman 100 F-21, F-21A Trainer/Sport F22			40-86	RA164-02000	30-55	RA066-10500	2	RA105-00200		RA063-01200	
<b>TECNAM</b>											
P2002 Sierra, P2002 Sierra RG			40-78B	RA164-01700	30-9	RA066-10600	2	RA105-00200			
P2006T, P2006T MRI			40-59B		30-59A	RA066-11200	2	RA105-00200			
P2008 US-LSA, P2008 JC			40-78B	RA164-01700	30-9	RA066-10600	2	RA105-00200			
P2010			40-59B		30-59A	RA066-11200	2	RA105-00200			
P2012			40-138B	RA164-05500	30-113A	RA066-06400	8	RA177-01600			
<b>Ted Smith Aerostar - see Aerostar</b>											
<b>The New Piper Aircraft Inc. - see Piper</b>											
<b>Textron see Beech or Cessna</b>											
<b>Thrush - also see Ayres, Snow, Marsh, or Rockwell</b>											
T660P			40-279A	RA164-23002	30-210C	RA066-13100	8	RA105-06700			
<b>Twin Commander - see Aero Commander</b>											
<b>Univair</b>											
(Alon) Aircoupe A2, A2A	w/Cleveland Disc Brakes		40-97A	RA164-02601	30-63A	RA066-10500	2	RA105-00200		RA063-01200	
(ERCO) Eroupe 415-C, -CD, -D, -E, -G,	w/Cleveland Disc Brakes		40-41	RA164-00300	30-30	RA066-10500	2	RA105-00200		RA063-01100	
(Fomey) Aircoupe F-1, F-1A	w/Cleveland Disc Brakes		40-41	RA164-00300	30-30	RA066-10500	2	RA105-00200		RA063-01100	
(Mooney) M10 Cadet/Coupe	w/Cleveland Disc Brakes		40-97A	RA164-02601	30-63, -63A	RA066-10500	2	RA105-00200		RA063-01200	
(Piper) J-3 Cub	w/Cleveland Brake STC		40-60A	RA164-06700	30-60, -60A	RA066-10600	4	RA105-00200			
(Piper) PA-11 Cub Special	w/Cleveland Brake STC		40-60	RA164-06700	30-60, -60A	RA066-10600	4	RA105-00200			
(Piper) PA-12 Super Cruiser	w/Cleveland Brake STC		40-60	RA164-06700	30-60, -60A	RA066-10600	4	RA105-00200			
(Piper) PA-14 Family Cruiser	w/Cleveland Disc Brakes		40-60	RA164-06700	30-60, -60A	RA066-10600	4	RA105-00200			
(Piper) PA-16 Clipper	w/Cleveland Disc Brakes		40-60	RA164-06700	30-60, -60A	RA066-10600	4	RA105-00200			
(Piper) PA-18 Super Cub	w/Cleveland Disc Brakes		40-60	RA164-06700	30-60, -60A	RA066-10600	4	RA105-00200			
(Piper) PA-18 Super Cub	w/Cleveland - 1.5" axles		40-84	RA164-01900	30-41, -41B	RA066-10600	4	RA105-00200			

Note: Please confirm brake assembly number. Part numbers with 'RA' are Rapco products. For Reference ONLY. For installation eligibility see FAA-PMA supplement.



Manufacturer Model	Year / Serial Number Notes	Conv/Mod Kit #	Wheel Assembly	Brake Disc	Brake Assembly	Lining	Linings Per Wheel	Rivet or Mounting Pin	Shim Insulators	Pressure Plate	Grease Seal
(Piper) PA-20 Piper Cub	w/Cleveland Disc Brakes		40-60	RA164-06700	30-60, -60A	RA066-10600	4	RA105-00200			
(Piper) PA-20 Piper Cub	w/Cleveland - 1.5" axles		40-84	RA164-01900	30-41, -41B	RA066-10600	4	RA105-00200			
(Piper) PA-20/22 Piper Cub	w/Cleveland - 1.5" axles		40-84	RA164-01900	30-41, -41B	RA066-10600	4	RA105-00200			
(Stinson) 108, 108-1, -2, -3, -5	w/Cleveland - 7.00-6 Tire		40-28	RA164-00500	30-18	RA066-10600	2	RA105-00200			
	w/Cleveland, early model		40-97E	RA164-02601	30-63Q	RA066-10500	2	RA105-00200		RA063-01200	
<b>Valmet</b>											
L-70 Millitrainer			40-75S,	RA164-04800	30-52K	RA066-10500	4	RA105-00200		RA063-01100	
L-90 TP Redigo			40-142	RA164-07800	30-127	RA066-06200	4	RA177-00300	RA068-01100		
<b>Varga</b>											
2150A, 2180 Kachina			40-97E	RA164-02601	30-63E	RA066-10500	2	RA105-00200		RA063-01200	
<b>Viking Air Limited - see de Havilland</b>											
<b>Vulcanair / Partenavia / G.A.F.</b>											
P.64B, P.66B Oscar	1970 and on		40-28	RA164-00500	30-18	RA066-10600	2	RA105-00200			
P.68C-160, P.66T Charlie Trainer			40-86B	RA164-02000	30-55	RA066-10500	2	RA105-00200		RA063-01200	
P.68, P.68B,			40-96E	RA164-02504	30-61E	RA066-10500	4	RA105-00200		RA063-01100	
P.68C, P.68C-TC	Heavy Duty		40-142	RA164-07800	30-127	RA066-06200	4	RA177-00300	RA068-02800		
AP68TP300			40-163	RA164-20500	30-139	RA066-06200	8	RA177-00300	RA068-01100	RA063-01100	
<b>Waco - also see Classic Aircraft</b>											
Meteor, Minerva, Vela			40-97A	RA164-02601	30-63A	RA066-10500	2	RA105-00200		RA063-01200	
YMF											RA154-03000
<b>Wetherly</b>											
201A, 201B, 201C, 620			40-101	RA164-03006	30-67D	RA066-10800	4	RA105-00200			
620	Heavy Duty Opt		40-101	RA164-03006	30-89B	RA066-10800	6	RA105-00200		RA063-01300	
620A, 620TP			40-101E	RA164-03006	30-89B	RA066-10800	4	RA105-00200		RA063-01300	
<b>Wing Aircraft</b>											
D-1 Deringer			40-84	RA164-01900	30-41B	RA066-10600	4	RA105-00200			

(PP) - Lining used on pressure plate. (BP) - Lining used on back plate. (HD) - Heavy Duty. N/A - Not Available  
For reference only. For installation eligibility refer to the FAA-PMA Supplement.

52725



**Section 2:  
Kit Planes**

Aircraft Make and Model	Wheel Size, # Bolt Holes & Size	Brake Kit No.	Wheel Assembly	Brake Disc	Brake Assembly	Lining	Linings per Wheel	Rivet or Mounting Pin	Shim Insulator	Pressure Plate
<b>Aircraft Designs</b>										
Stallion	6.00-6, Three 5/16"	199-60	40-75B	RA164-01501	30-52	RA066-10500	4	RA105-00200		RA063-01100
<b>American Homebuilts</b>										
John Doe STOL	6.00-6, Three 5/16"	199-104C	40-59A	RA164-07500*	30-59A	RA066-11200		RA105-00200		
	6.00-6, Three 1/4"	199-105C	40-113X	RA164-04000	30-75X	RA066-10500	2	RA105-00200		RA063-01200
<b>Aviation Maintenance Ltd.</b>										
Stearman 75	6.50-10, Nine 1/4"	199-167	40-256	RA164-03006	30-195	RA066-10800	4	RA105-00200		
<b>D and J Harmon</b>										
Harmon Rocket	5.00-5, Three 1/4"	199-152	40-151	RA164-08500	30-133	RA066-10500	2	RA105-00200		RA063-01200
<b>D.L.F. Holdings</b>										
Tango	5.00-5, Three 1/4"	199-152	40-151	RA164-09900*	30-133	RA066-10500	2	RA105-00200		RA063-01200
<b>Dean Wilson</b>										
Whitney Boomerang	5.00-5, Three 1/4"	199-102	40-78B	RA164-01700	30-9	RA066-10600	2	RA105-00200		
<b>Epic</b>										
LT (Drive Key PN: RA205-02900)			40-343							
<b>Explorer Aeronautique</b>										
Private Explorer Standard	6.00-6, Three 5/16"	199-62	40-75D	RA164-03601	30-52N	RA066-10500	4	RA105-00200		RA063-01100
Private Explorer Float Equipped	7.50-10, Three 1/4"		40-101	RA164-03006	30-67B	RA066-10800	4	RA105-00200		
<b>Express Aircraft</b>										
CT, S90, Express 2000 / 2000RG	6.00-6, Three 5/16"	199-60	40-75B	RA164-01501	30-52	RA066-10500	4	RA105-00200		RA063-01100
<b>Four Winds Aircraft</b>										
192 / 210 / 250T	6.00-6, Three 5/16"	199-60	40-75B	RA164-01501	30-52	RA066-10500	4	RA105-00200		RA063-01100
<b>Hensley Aircraft</b>										
F-19 Wolf Aerobatic	6.00-6, Three 5/16"	199-46	40-97A	RA164-02601	30-63A	RA066-10500	2	RA105-00200		RA063-01200
F-19 Wolf Utility	6.00-6, Three 5/16"	199-62	40-75B	RA164-01501	30-52	RA066-10500	4	RA105-00200		RA063-01100
<b>Lancair</b>										
Lancair IV Standard	6.00-6, Three 5/16"	199-208	40-96E		30-61E	RA066-10500	4	RA105-00200		RA063-01100
Lancair IV High Energy	6.00-6, Three 5/16"	199-224	40-406		30-233	RA066-06200	4	RA177-00300	RA068-01100	RA063-01100
Lancair IV High Energy Upgrade		199-224A			30-233	RA066-06200		RA177-00300	RA068-01100	RA063-01100
Legacy FG / RG, 2000	5.00-5, Three 1/4"	199-152	40-151	RA164-08500	30-133	RA066-10500	2	RA105-00200		RA063-01200
<b>Murphy Manufacturing</b>										
Rebel, SR2500 Supre Rebel, Maverick Renegade Spirit, Elite	6.00-6, Six 1/4"	199-71	40-60A	RA164-06700	30-60A	RA066-10600	4	RA105-00200		
<b>Pacific Aerosystems</b>										
Sky Aero	5.00-5, Three 1/4"	199-102	40-78B	RA164-01700	30-9	RA066-10600	2	RA105-00200		
F300	6.00-6, Three 5/16"	199-60A	40-75B	RA164-01501	30-52N	RA066-10500	4	RA105-00200		RA063-01100
<b>Performance Aircraft</b>										
Legend	6.00-6, Three 5/16"		40-96E	RA164-02504	30-61E	RA066-10500	4	RA105-00200		RA063-01100
<b>Pitts</b>										
S1-C, S1-S (Pitts Special)	5.00-5, Three 1/4"	199-102	40-78B	RA164-01700	30-9	RA066-10600	2	RA105-00200		
	5.00-5, Three 1/4"	199-103	40-78J	RA164-01700	30-9C	RA066-10600	2	RA105-00200		
<b>Rans</b>										
S-7C	6.00-6, Three 5/16"	199-104	40-59A	RA164-07500*	30-59A	RA066-11200	2	RA105-00200		
	6.00-6	199-204	40-281		30-214	RA066-10500	2	RA105-00200		RA063-01200
S-16	5.00-5, Three 1/4"	199-102	40-78B	RA164-01700	30-9	RA066-10600	2	RA105-00200		
<b>SkyStar Aircraft</b>										
Kit Fox	6.00-6	199-215	40-281		30-224	RA066-10500	2	RA105-00200		RA063-01200
Pulsar	5.00-5, Three 1/4"	199-102	40-78B	RA164-01700	30-9	RA066-10600	2	RA105-00200		
<b>Steen Aero Lab</b>										
Skybolt	6.00-6, Three 5/16"	199-104	40-59A	RA164-07500*	30-59A	RA066-11200	2	RA105-00200		
	6.00-6, Three 1/4"	199-105	40-113X	RA164-04000	30-75X	RA066-10500	2	RA105-00200		RA063-01200
<b>Stolp Starduster</b>										
SA-100, SA-101, SA-300, SA-500, SA-750, SA-900	5.00-5, Three 1/4"	199-103	40-78J	RA164-01700	30-9C	RA066-10600	2	RA105-00200		
	6.00-6, Three 5/16"	199-104	40-59A	RA164-07500*	30-59A	RA066-11200	2	RA105-00200		
<b>Ultravia Aero Int'l</b>										
Pelican PL912/914	5.00-5, Three 1/4"	199-102	40-78B	RA164-01700	30-9	RA066-10600	2	RA105-00200		
<b>Vans Aircraft</b>										
RV-3 thru RV-9	5.00-5, Three 1/4"	199-102	40-78B	RA164-01700	30-9	RA066-10600	2	RA105-00200		
RV10	6.00-6, Three 5/16"	199-104	40-59A	RA164-07500*	30-59A	RA066-11200	2	RA105-00200		
<b>Velocity Aircraft</b>										
SE / XL	6.00-6, Three 5/16"	199-60	40-75B	RA164-01501	30-52	RA066-10500	4	RA105-00200		RA063-01100
<b>Wag Aero</b>										
Sport Trainer, Observer, Acro Trainer, Acro Sport I & II, Wag-a-bond Classic, Super Sport, Wag-a-bond Traveler, Sportsman 2+2, Wag-a bond	5.00-5, Three 1/4"	199-102	40-78B	RA164-01700	30-9	RA066-10600	2	RA105-00200		
	5.00-5, Three 1/4"	199-103	40-78J	RA164-01700	30-9C	RA066-10600	2	RA105-00200		
	6.00-6, Three 5/16"	199-104	40-59A	RA164-07500*	30-59A	RA066-11200	2	RA105-00200		
	6.00-6, Three 1/4"	199-105	40-113X	RA164-04000	30-75X	RA066-10500	2	RA105-00200		RA063-01200
<b>Zenair</b>										
6.00 x 6: CH200, 250, 300 (Tri-Z), Zipper, Cricket MC-15, Stol CH-701	5.00-5, Three 1/4"	199-102	40-78B	RA164-01700	30-9	RA066-10600	2	RA105-00200		
	6.00-6, Three 5/16"		40-59A	RA164-07500*						

\* RA164-09900 and RA164-07500 are for use only on experimental or non U.S type certificated aircraft.

For reference only. For installation eligibility refer to the FAA-PMA Supplement.

21225

Note: Please confirm brake assembly number. Part numbers with 'RA' are Rapco products. For Reference ONLY. For installation eligibility see FAA-PMA supplement.



**Section 3:**  
**Experimental Aircraft**

Manufacturer Model	Wheel Size, # Bolt Holes & Size	Brake Kit No.	Wheel Assembly	Brake Disc	Brake Assembly	Lining	Linings per Wheel	Rivet or Mounting Pin	Shim Insulator	Pressure Plate
Experimental	6.00-6, Three 5/16"	199-46	40-97A	RA164-02601	30-63A	RA066-10500	2	RA105-00200		RA063-01200
Experimental	6.00-6, Three 5/16"	199-60	40-75B	RA164-01501	30-52	RA066-10500	4	RA105-00200		RA063-01100
Experimental	6.00-6, Three 5/16"	199-62	40-75D	RA164-03601	30-52N	RA066-10500	4	RA105-00200		RA063-01100
Experimental	6.00-6 Three 1/4"	199-105C	40-113X	RA164-04000	30-75X	RA066-10500	2	RA105-00200		
Experimental	6.00-6, Three 5/16"	199-208	40-96E	RA164-02504	30-61E	RA066-10500	4	RA105-00200		RA063-01100
Experimental	6.00-6, Three 5/16"	199-224	40-406	RA164-02504	30-233	RA066-06200	4	RA177-00300	RA068-01100	RA063-01100
Experimental		199-251	40-281		30-224	RA066-10500	2	RA105-00200		
Experimental	5.00-5, Three 1/4"	199-09300	40-230	RA164-09900*	30-181A	RA066-10600	2	RA105-00200		
Experimental	5.00-5, Three 1/4"	199-10200	40-78B	RA164-01700	30-9	RA066-10600	2	RA105-00200		
Experimental	5.00-5, Three 1/4"	199-10300	40-78J	RA164-01700	30-9C	RA066-10600	2	RA105-00200		
Experimental	6.00-6, Three 5/16"	199-10400	40-59A	RA164-07500*	30-59A	RA066-11200	2	RA105-00200		
Experimental	6.00-6, Three 1/4"	199-10500	40-113X	RA164-04000	30-75X	RA066-10500	2	RA105-00200		
Experimental	5.00-5, Three 1/4"	199-15200	40-151	RA164-08500	30-133	RA066-10500	2	RA105-00200		
Experimental	5.00-5, Three 1/4"	199-15201	40-1501A	RA164-08500	30-133	RA066-10500	2	RA105-00200		
Experimental	5.00-5, Three 1/4"	199-15200	40-151	RA164-08500	30-133	RA066-10500	2	RA105-00200		
Experimental	5.00-5, Three 1/4"	199-15600	40-230		30-133	RA066-10600	2	RA105-00200		
Experimental	6.00-6, Three 1/4"	199-08400	40-113	RA164-04000	30-75	RA066-10500	2	RA105-00200		
Experimental	6.00-6, Three 1/4"	199-08401	40-113	RA164-04000	30-75A	RA066-10500	2	RA105-00200		
Experimental	6.00-6, Three 1/4"	199-08403	40-113	RA164-04000	30-75	RA066-10500	2	RA105-00200		
Experimental	6.00-6, Three 1/4"	199-08403	40-113	RA164-04000	30-75A	RA066-10500	2	RA105-00200		
Experimental	5.00-5, Three 1/4"	199-19700	40-151	RA164-08500	30-164	RA066-06200	2	RA177-00300		
Experimental		199-20400	40-281		30-214	RA066-10500	2	RA105-00200		
Experimental		199-22300	40-281		30-214B	RA066-10500	2	RA105-00200		

\* RA164-09900 and RA164-07500 are for used only on experimental or non U.S type certificated aircraft.

For reference only.

61623

**Section 4:**  
**Floatplane - Original Equipment Floats**

Manufacturer Model	Year / Serial Number Notes	Conv/Mod Kit #	Wheel Assembly	Brake Disc	Brake Assembly	Lining	Linings Per Wheel	Rivet or Mounting Pin	Shim Insulators	Pressure Plate
<b>Aerocet</b>										
3500 Series			40-418A 40-118C		30-241	RA066-10500	4	RA105-00200		RA063-01100
<b>Baumann Floats</b>										
BF2150			40-78A	RA164-01700	30-9C	RA066-10600	2	RA105-00200		
BF2550										
BF2750			40-481A		30-241	RA066-10500	4	RA105-00200		RA063-01100
<b>Wipaire</b>										
2100/2350 Series			40-78A	RA164-01700	30-9C	RA066-10600	2	RA105-00200		
3700/4000 Series			40-78J							
3000/3450 Series			40-418		30-241	RA066-10500	4	RA105-00200		RA063-01100
6000/8000/8750 Series			40-118B							
10000/13000 Series			40-101 40-101D	RA164-03006	30-67C	RA066-10800	4	RA105-00200		
<b>Floatplane - Conversion Floats</b>										
<b>Edo</b>										
	6.00-6		40-74		30-51	RA066-10600	4	RA105-00200		
	6.00-6		40-74A		30-51	RA066-10600	4	RA105-00200		

For reference only.

22625



**Section 5:**

**McCauley Brake Disc - Cross Reference and Comparison Guides**

McCauley wheels are identified by their six spoke pattern. Cleveland wheels do not have a spoke appearance. Always be sure to confirm your disc dimensions with the dimensional comparison guide at the end of this section.

**McCauley Wheel Assembly P/N - Cross Reference To Brake Disc**

Aircraft Model	Year	Bolt Holes	Overall Depth	McCauley Wheel Assy.	McCauley Brake Disc	RAPCO Brake Disc
150, A150, 152	1971 to 1973	6 - 1/4"		D-30063	B-30007 *	N/A
F150, F152	1973 to 1976	6 - 5/16"	2.070"	D-30260	B-30195	RA164-30195
FA152 (Reims)	1976	6 - 5/16"	2.070"	D-30580	B-30195	RA164-30195
	1976 to 1977	6 - 5/16"	1.965"	D-30291-6	B-30440	RA164-30440
	1977	6 - 1/4"		D-30600-1	B-30007 *	N/A
	1978 and on	3 - 5/16"	1.515"	D-30660-1	C-30615-1	RA164-30615-1
172, R172	1971 to 1973	6 - 1/4"		D-30063	B-30007*	N/A
F172 (Reims)	1973 to 1976	6 - 5/16"	2.070"	D-30260	B-30195	RA164-30195
FR172 (Reims)	1976	6 - 5/16"	2.070"	D-30580	B-30195	RA164-30195
	1977	3 - 5/16"	1.515"	D-30600-1	C-30615-1	RA164-30615-1
	1978 and on	3 - 5/16"	1.515"	D-30660-1	C-30615-1	RA164-30615-1
172RG Cutlass	1980 and on	3 - 5/16"	1.515"	D-30660-1	C-30615-1	RA164-30615-1
177, 177RG	1975	6 - 5/16"	2.070"	D-30580	B-30195	RA164-30195
F177RG	1976	6 - 5/16"	1.965"	D-30291-6	B-30440	RA164-30440
F177RG (Reims)	1977	6 - 1/4"		D-30600-1	B-30007 *	N/A
	1978 and on	3 - 5/16"	1.515"	D-30660-1	C-30615-1	RA164-30615-1
180 Series Skywagon	1973 to 1974			D-30063-1		N/A
	1974	6 - 5/16"	2.155"	D-30291-3	C-30414	RA164-30414
				D-30063-4		N/A
		6 - 5/16"	2.335"	D-30291-1	C-30388	RA164-30388
1978 and on	3 - 5/16"	1.890"	D-30660-2	C-30615-2	RA164-30615-2	
182 Series	1976	6 - 5/16"	1.965"	D-30291-6	B-30440	RA164-30440
F182 (Reims)	1977	3 - 5/16"	1.515"	D-30600-1	C-30615-1	RA164-30615-1
	1978 to 1980	3 - 5/16"	1.515"	D-30660-1	C-30615-1	RA164-30615-1
T182	1981 and on	3 - 5/16"	1.660"	D-30660-3	C-30615-3	RA164-30615-3
185 Series Skywagon	1973 to 1974			D-30063-1		N/A
	1974	6 - 5/16"	2.155"	D-30291-3	C-30414	RA164-30414
				D-30063-4		N/A
		6 - 5/16"	2.335"	D-30291-1	C-30388	RA164-30388
1978 and on	3 - 5/16"	1.890"	D-30660-2	C-30615-2	RA164-30615-2	
206 Series	1974			D-30063-2		N/A
	1974 to 1978	6 - 5/16"	2.100"	D-30291-2	C-30398	RA164-30398
	1978 and on	3 - 5/16"	1.660"	D-30660-3	C-30615-3	RA164-30615-3
	1974			D-30063-4		N/A
	1974 to 1978 (8.00x6)	6 - 5/16"	2.335"	D-30291-1	C-30388	RA164-30388
	1978 and on (8.00x6)	3 - 5/16"	1.890"	D-30660-2	C-30615-2	RA164-30615-2
210 Series	1974			D-30063-2		N/A
	1974 to 1978	6 - 5/16"	2.100"	D-30291-2	C-30398	RA164-30398
	1978 and on	3 - 5/16"	1.660"	D-30660-3	C-30615-3	RA164-30615-3

\*McCauley Brake Disc P/N: B-30007 with Six mounting holes for 1/4" bolts. Try web search.

For reference only.



## McCauley Brake Disc Comparison Guide

McCauley wheel assemblies can be identified by their six spoke design as compared to Cleveland wheels which have a smooth dish like appearance. To confirm you are purchasing the same disc as on your aircraft, count the number of bolt holes then measure the overall depth of your disc from the outside of the mounting flange to the outside of the wear surface, then compare it with the chart below. McCauley brake assemblies require the RA066-30026 replacement linings with a whole spread of 1.75".

### McCauley Brake Disc Dimensions Guide

Brake Disc		Specifications						Wheel Assemblies With Which Disc Is Used In	
RAPCO Disc PN	McCauley Disc PN	Bolt Hole, Quantity & Size	Overall Depth	Overall Diameter	OD Base	Wear Surface Thickness	Minimum Wear Thickness	McCauley Wheel Assembly PN	Cessna Wheel Assembly PN
N/A	B-30007	6 Hole, (1/4")	1.964"					D-30063	C163002-0101
RA164-30195	B-30195	6 Hole, 0.320 (5/16")	2.070"	7.495"	5.490"	0.225"	0.190"	D-30260 or D-30580	C163003-0101 or C163003-0102
RA164-30388	C-30388	6 Hole, 0.320 (5/16")	2.335"	7.495"	5.490"	0.355"	0.325"	D-30291-1 or -5	C163004-0101
RA164-30398	C-30398	6 Hole, 0.320 (5/16")	2.100"	7.495"	5.490"	0.355"	0.325"	D-30291-2	C163004-0102 or C163006-0103
RA164-30414	C-30414	6 Hole, 0.320 (5/16")	2.155"	7.495"	5.490"	0.355"	0.325"	D-30291-3	C163004-0103
RA164-30440	B-30440	6 Hole, 0.320 (5/16")	1.965"	7.495"	5.490"	0.215"	0.190"	D-30291-4 or -6	C163004-0104
RA164-30615-1	C-30615-1 or -4	3 Hole, 0.320 (5/16")	1.515"	7.495"	5.485"	0.215"	0.190"	D-30600-1	C163005-0101 or C163006-0101
RA164-30615-2	C-30615-2	3 Hole, 0.320 (5/16")	1.890"	7.495"	5.500"	0.355"	0.330"	D-30660-2	C163006-0102
RA164-30615-3	C-30615-3	3 Hole, 0.320 (5/16")	1.660"	7.495"	5.500"	0.355"	0.330"	D-30660-3	C163006-0103

For reference only. For installation eligibility refer to the FAA-PMA Supplement.

32921

## Brake Lining Installation Tool RA825 RIVET TOOL



**Quality Manufactured tool for installing most general aviation style brake linings using Rapco Brass Rivets.**

- \* Complete with: Rivet Punch, Set, and Anvil for setting rivets.
- \* More convenient and easier to use than most punch style tools.
- \* Will not crack or distort brake linings.
- \* Can be used in vise or hand held.



### Cessna Wheel Assembly P/N - Cross Reference To Brake Disc

Cessna Model	Bolt Hole Quantity,	Overall Depth	Cessna Wheel Assy.	McCauley Brake Disc	RAPCO Brake Disc
150, 150A	Six, 5/16"	1.965"	C163004-0104	B-30440	RA164-30440
	Six, 5/16"	2.070"	C163003-0101 or C163003-0102	B-30195	RA164-30195
	Six, 1/4"		C163002-0101	B-30007	N/A
152, A152, F152, FA152	Three, 5/16"	1.515"	C163005-0101 or C163006-0101	C-30615-1	RA164-30615-1
172, F172, R172, FR172	Six, 5/16"	1.965"	C163004-0104	B-30440	RA164-30440
	Six, 5/16"	2.070"	C163003-0101 or C163003-0102 or C163004-0104	B-30195	RA164-30195
	Six, 1/4"		C163002-0101	B-30007	N/A
172, F172, 172RG	Three, 5/16"	1.515"	C163006-0101	C-30615-1	RA164-30615-1
177 177RG	Three, 5/16"	1.515"	C163005-0101	C-30615-1	RA164-30615-1
	Three, 5/16"	1.515"	C163005-0101 or C163006-0101	C-30615-1	RA164-30615-1
180	Six, 5/16"	2.155"	C163004-0103	C-30414	RA164-30414
	Six, 5/16"	2.335"	C163004-0101	C-30388	RA164-30388
	Three, 5/16"	1.660"	C163006-0103 Std.	C-30615-3	RA164-30615-3
	Three, 5/16"	1.890"	C163006-0102 HD	C-30615-2	RA164-30615-2
182, F182  R182, FR182, TR182	Three, 5/16"	1.515"	C163006-0101 C163006-0103	C-30615-1	RA164-30615-1
	Three, 5/16"	1.660"	C163006-0103	C-30615-3	RA164-30615-3
185	Six, 5/16"	2.155"	C163004-0103	C-30414	RA164-30414
	Six, 5/16"	2.335"	C163004-0101	C-30388	RA164-30388
	Three, 5/16"	1.660"	C163006-0103 Std.	C-30615-3	RA164-30615-3
	Three, 5/16"	1.890"	C163006-0102 HD	C-30615-2	RA164-30615-2
U206, TU206	Six, 5/16"	2.100"	C163004-0102	C-30398	RA164-30398
	Six, 5/16"	2.335"	C163004-0101	C-30388	RA164-30388
	Three, 5/16"	1.660"	C163006-0103 Std.	C-30615-3	RA164-30615-3
	Three, 5/16"	1.890"	C163006-0102 HD	C-30615-2	RA164-30615-2
210, T210, P210	Six, 5/16"	2.100"	C163006-0103	C-30398	RA164-30398
	Three, 5/16"	1.660"	C163006-0103	C-30615-3	RA164-30615-3

For reference only.

111424



## RAPCO inc. BRAKE COMPONENT CROSS REFERENCE with Minimum Wear Thickness Specifications

### FAA-PMA Approved

Brake Disc, Linings, Overhaul Kits, Rivets, Mounting Pins, Pressure Plates, Shim Insulators, Drive Keys  
Wear pads, Grease Seals and Pressure Plate Assemblies

### Brake Discs

RAPCO PN	Cleveland PN		McCauley PN	Piper PN	Bolt Holes Quantity - Size	Slotted Disc	Minimum Wear Thickness In./mm
	Current	Superseded					
RA164-00206	164-00206	164-2F		754-650	3 - 1/4"		***
RA164-00300	164-00300	164-3			3 - 5/16"		0.205" / 5.207 mm
RA164-00400	164-00400	164-4			3 - 1/4"		0.162" / 4.115 mm
RA164-00500	164-00500	164-5		754-518	3 - 1/4"		0.157" / 3.988 mm
RA164-00700	164-00700	164-7			3 - 1/4"		0.345" / 8.763 mm
RA164-00806	164-00806	164-8F			9 - 1/4"		0.334" / 8.484 mm
RA164-00900	164-00900	164-9 164-1		754-530	3 - 1/4"		0.227" / 5.766 mm
RA164-01000	164-01000	164-10		754-831	6 - 1/4"		0.345" / 8.763 mm
RA164-01300	164-01300	164-13		754-528	3 - 1/4"		0.227" / 5.764 mm
RA164-01406	164-01406	164-14F			9 - 1/4"		0.334" / 8.484 mm
RA164-01501	164-01501	164-15A			3 - 5/16"		0.327" / 8.306 mm
RA164-01506	164-01506	164-15F			3 - 5/16"		0.327" / 8.306 mm
RA164-01600	164-01600	164-16			3 - 5/16"		0.157" / 3.988 mm
RA164-01700	164-01700	164-17		754-617	3 - 1/4"		0.167" / 4.242 mm
RA164-01900	164-01900	164-19		754-545	3 - 5/16"		0.227" / 5.766 mm
RA164-02000	164-02000	164-20		754-535	3 - 5/16"		0.205" / 5.207 mm
RA164-02201	164-02201	164-22A		754-554	3 - 5/16"		0.345" / 8.763 mm
RA164-02300	164-02300	164-23		754-643	3 - 5/16"		0.345" / 8.763 mm
RA164-02504	164-02504				3 - 5/16"		0.445" / 11.303 mm
RA164-02505	164-02505				3 - 5/16"		0.445" / 11.303 mm
RA164-02601	164-02601	164-26A			3 - 5/16"		0.205" / 5.207 mm
RA164-02706	164-02706	164-27F			6 - 5/16"		0.330" / 8.382 mm
RA164-02707	164-02707	164-27G			6 - 5/16"		0.330" / 8.382 mm
RA164-02800	164-02800	164-28			6 - 1/4"		0.227" / 5.766 mm
RA164-03006	164-03006	164-30F			9 - 1/4"		0.282" / 7.163 mm
RA164-03106	164-03106	164-31F			9 - 1/4"		0.163" / 4.140 mm
RA164-03206	164-03206	164-32F		754-651 760-538	3 - 1/4"		***
RA164-03300	164-03300	164-33		754-562	3 - 5/16"		0.235" / 5.969 mm
RA164-03506	164-03506	164-35F			9 - 1/4"		0.260" / 6.604 mm
RA164-03601	164-03601	164-36A			3 - 5/16"		0.327" / 8.306 mm
RA164-03906	164-03906	164-39F			9 - 5/16"		0.600" / 15.240 mm
RA164-04000	164-04000	164-40			3 - 1/4"		0.205" / 5.207 mm
RA164-04300	164-04300	164-43			3 - 1/4"		0.205" / 5.207 mm
RA164-04406	164-04406	164-44F			9 - 1/4"		0.334" / 8.484 mm
RA164-04800 *	164-04800	164-48			3 - 5/16"		0.327" / 8.306 mm
RA164-05006	164-05006	164-50F		456-818	6 - 5/16"		0.475" / 12.065 mm
RA164-05500	164-05500	164-55			9 - 5/16"	Slotted	0.492" / 12.497 mm
RA164-05700	164-05700	164-57		754-612	3 - 1/4"		0.525" / 13.335 mm
RA164-05806	164-05806	164-58F			9 - 5/16"		0.395" / 10.033 mm
RA164-06106	164-06106	164-61F			6 - 5/16"	Slotted	0.475" / 12.065 mm
RA164-06306	164-06306	164-63F			9 - 5/16"	Slotted	0.465" / 11.811 mm
RA164-06406	164-06406	164-64F			9 - 1/4"	Slotted	0.465" / 11.811 mm
RA164-06506	164-06506	164-65F			6 - 5/16"		0.240" / 6.096 mm
RA164-06700	164-06700	164-67			6 - 1/4"		0.220" / 5.588 mm
RA164-06900	164-06900	164-69			3 - 5/16"		0.205" / 5.207 mm
RA164-07200	164-07200	164-72			8 - 3/8"	Slotted	0.492" / 12.497 mm
RA164-07400	164-07400	164-74			8 - 5/16"	Slotted	0.492" / 12.497 mm
RA164-07500 *	164-07500	164-75			3 - 5/16"		0.205" / 5.207 mm
RA164-07700	164-07700	164-77		754-642	9 - 5/16"	Slotted	0.470" / 11.938 mm
RA164-07800	164-07800	164-78			6 - 5/16"	Slotted	0.450" / 11.43 mm
RA164-07906	164-07906	164-79F			9 - 1/4"	Slotted	0.465" / 11.811 mm
RA164-08100 *	164-08100	164-81			6 - 5/16"	Slotted	0.450" / 11.430 mm
RA164-08200	164-08200	164-82			6 - 5/16"	Slotted	0.327" / 8.306 mm
RA164-08300	164-08300	164-83			6 - 5/16"		0.327" / 8.306 mm
RA164-08406	164-08406	164-84F			6 - 5/16"	Slotted	0.330" / 8.302 mm
RA164-08500	164-08500	164-85			3 - 1/4"		0.325" / 8.255 mm
RA164-09100	164-09100	164-91			9 - 5/16"	Slotted	0.492" / 12.497 mm
RA164-09900 *	164-09900	164-99			3 - 1/4"		0.275" / 6.985 mm

\* Indicates a disc part number for use on experimental aircraft.

\*\*\* For minimum wear thickness on Piper Aztec brake disc RA164-00206 or RA164-03206 perform the following procedure. First measure the linings to make sure they are each above the minimum wear of 0.100 inch or ( 0.76 mm ) thick, if not replace. Next measure the cumulative thickness of the two linings, the pressure plate and the brake disc. If the cumulative thickness of these four items is less than 1.00 inch ( 25.40 mm ) the disc is considered to be below minimum wear thickness and should be replaced. **For reference only.**



# Section 6 - Cross Reference Brake Discs

RAPCO PN	Cleveland PN		McCauley PN	Piper PN	Bolt Holes Quantity - Size	Slotted Disc	Minimum Wear Thickness In./mm
	Current	Superseded					
RA164-20206	164-20206	164-202F			9 - 5/16"		0.334" / 8.484 mm
RA164-20306	164-20306	164-203F			6 - 5/16"	Slotted	0.465" / 11.811 mm
RA164-20500	164-20500	164-205			6 - 5/16"	Slotted	0.525" / 13.335 mm
RA164-20600	164-20600	164-206		754-658	8 - 5/16"	Slotted	0.455" / 11.557 mm
RA164-20700	164-20700	164-207			8 - 5/16"	Slotted	0.410" / 10.414 mm
RA164-20806	164-20806	164-208F			6 - 5/16"	Slotted	0.475" / 12.065 mm
RA164-20900	164-20900	164-209			8 - 3/8"	Slotted	0.410" / 10.414 mm
RA164-21000	164-21000	164-210			6 - 3/8"	Slotted	0.436" / 11.074 mm
RA164-21100 *	164-21100	164-211			9 - 5/16"	Slotted	0.492" / 12.497 mm
RA164-21200 *	164-21200	164-212			9 - 5/16"		0.327" / 8.306 mm
RA164-21600	164-21600	164-216		754-686	6 - 5/16"	Slotted	0.405" / 10.287 mm
RA164-21900	164-21900	164-219			9 - 5/16"	Slotted	0.590" / 14.986 mm
RA164-22000	164-22000	164-220			8 - 3/8"	Slotted	0.360" / 9.144 mm
RA164-22201	164-22201	164-222A			9 - 5/16"	Slotted	0.537" / 13.640 mm
RA164-22202	164-22202	164-222B			9 - 1/4"	Slotted	0.537" / 13.640 mm
RA164-22400	164-22400	164-224			9 - 3/8"	Slotted	0.385" / 9.779 mm
RA164-22900	164-22900	164-229			8 - 3/8"	Slotted	0.410" / 10.414 mm
RA164-23000	164-23000	164-230			9 - 3/8"	Slotted	0.565" / 14.351 mm
RA164-23001	164-23001				9 - 3/8"	Slotted	0.582" / 14.783 mm
RA164-23002	164-23002				9 - 3/8"	Slotted	0.582" / 14.783 mm
RA164-24200	164-24200	164-242			3 - 1/4"		0.167" / 4.242 mm
RA164-24400	164-24400	164-244			3 - 5/16"		0.290" / 7.366 mm
RA164-30195	164-30195	164-09300 164-93	B-30195		6 - 5/16"		0.190" / 4.826 mm
RA164-30388	164-30388	164-09700 164-97	C-30388		6 - 5/16"		0.325" / 8.255 mm
RA164-30398	164-30398	164-09600 164-96	C-30398		6 - 5/16"		0.325" / 8.255 mm
RA164-30414	164-30414	164-09500 164-95	C-30414		6 - 5/16"		0.325" / 8.255 mm
RA164-30440	164-30440	164-09200 164-92	B-30440		6 - 5/16"		0.190" / 4.826 mm
RA164-30615-1	164-30615-1	164-08800 164-88	C-30615-1 C-30615-4		3 - 5/16"		0.190" / 4.826 mm
RA164-30615-2	164-30615-2	164-08900 164-89	C-30615-2		3 - 5/16"		0.330" / 8.382 mm
RA164-30615-3	164-30615-3	164-09000 164-90	C-30615-3		3 - 5/16"		0.330" / 8.382 mm

\* Asteriks denotes that the particular disc is for an experimental aircraft and not FAA approved for installation on US TC'd aircraft.

\*\*\* For minimum wear thickness on Piper Aztec brake disc RA164-00206 or RA164-03206 perform the following procedure.

First measure the linings to make sure they are each above the minimum wear of 0.100 inch or ( 0.76 mm ) thick, if not replace.

Next measure the cumulative thickness of the two linings, the pressure plate and the brake disc.

If the cumulative thickness of these four items is less than 1.00 inch ( 25.4 mm ) the disc is considered to be

below minimum wear thickness and should be replaced. For reference only.



# Section 6 - Cross Reference Linings

## Linings

For Minimum Wear Thickness see notation below.

RACO PN		Cleveland PN		McCauley	Beechcraft	Cessna	Piper	# Rivet Holes or	Rivets &
Current	Superseded	Current	Superseded	PN	PN	PN	PN	Mounting Holes	Mounting Pins
<b>Metallic (Sintered Steel)</b>									
RA066-02200	RA66-22	066-02200	66-22			66-22	579-467	2 Mounting Holes	RA177-00300
RA066-03300	RA66-33	066-03300	66-33			66-33	752-363	2 Mounting Holes	RA177-00300, or RA177-00400
RA066-04400	RA66-44	066-04400	66-44					2 Mounting Holes	RA177-00300
RA066-06200	RA66-62 RA66-19 RA66-105M	066-06200	66-62 66-19			66-36	761-197 752-336	2 Mounting Holes 2 Mounting Holes	RA177-00300
RA066-06400		066-06400	66-64					2 Mounting Holes	RA177-01600
RA066-06500	RA66-65 RA66-15 **	066-06500	66-65 66-15 **				761-196 752-335 **	2 Mounting Holes 4 Mounting Holes	RA177-00300
RA066-06600	RA66-66	066-06600	66-66				761-211	2 Mounting Holes	RA177-01600
RA066-06700		066-06700						2 Mounting Holes	RA177-00300
RA066-06800	RA66-68	066-06800	66-68				761-212	2 Mounting Holes	RA177-01600
RA066-07300		066-07300	66-73					3 Mounting Holes	RA177-01600
RA066-09000		066-09000	66-90 66-79					3 Mounting Holes & 1 Rivet Holes	RA177-01600 & RA105-00200
RA066-09100		066-09100	66-91					Direct Mounting	None
RA066-09200		066-09200	66-92					Direct Mounting	None
RA066-09700		066-09700	66-97					2 Mounting Holes	RA177-00300
RA066-10000		066-10000	66-100					3 Mounting Holes & 1 Rivet Holes	RA177-01600 & RA105-00200
RA066-15300		066-15300						2 Mounting Holes	RA177-00300
<b>Organic (Semi Metallic)</b>									
RA066-10500	RA66-105	066-10500	066-03000 66-105 66-55 (HD) 66-30		36-8001-23	66-30	752-342	2 Rivet Holes	RA105-00200
RA066-10600	RA66-106	066-10600	66-106 66-57 (HD) ** 66-56 (HD) 66-3 ** 66-2			3007 ** 3006	752-309 ** 752-308 ** 761-202	3 Rivet Holes 6 Rivet Holes 3 Rivet Holes 6 Rivet Holes 3 Rivet Holes	RA105-00200 RA105-00200
RA066-10800	RA66-108	066-10800	66-108 66-59 (HD) 66-35			66-35		2 Rivet Holes	RA105-00200
RA066-11000		066-11000	66-110 66-39					2 Rivet Holes	RA105-00200
RA066-11100	RA66-111	066-11100	66-111 66-58 (HD) 66-4		35-204	35-204	752-338	3 Rivet Holes	RA105-00200
RA066-11200	RA66-112	066-11200	66-112 66-71 (HD)				761-239	2 Rivet Holes	RA105-00200
RA066-13100		066-13100						3 Rivet Holes	RA105-06700
RA066-14100		066-14100						3 Rivet Holes	RA105-00200
RA066-14800		066-14800						3 Rivet Holes	RA105-00200
RA066-30026	RA66-109	066-30026	66-109 66-88 (HD) 66-87	B-30026		B30026		2 Rivet Holes	RA105-00200

\*\* Double length lining, obsolete, replaced by two each of the current part number.

(HD) Heavy Duty

Minimum Wear Thickness for organic or metallic linings, except the RA066-09100 and RA066-09200, is 0.100 inch ( 2.54 mm ) thick.

For the RA066-09100 and RA066-09200 linings, the minimum wear thickness of the sintered lining material by itself is 0.030 inch (0.76mm) thick.

For reference only.

22625



# 30 plus years and over 50,000 Brake Overhaul Kits produced: Experience... The Rapco/RFS advantage

Pilatus Aircraft, Ltd: Pilatus PC-12, PC-12/45, PC-12/47 and PC-12/47E  
equipped with 30-244 Brake Assemblies

## RA199-575A Brake Kit Contents:

- |                 |                     |
|-----------------|---------------------|
| 1 - RA095-01100 | WASHER              |
| 6 - RA107-03700 | WIPER               |
| 6 - RA101-02500 | PISTON O-RING       |
| 2 - RA101-00700 | BLEEDER PORT O-RING |
| 3 - RA159-07400 | ROTATING DISC       |
| 72- RA109-03000 | WEAR PAD            |
| 55- RA105-08701 | RIVET               |
| 55- RA105-02401 | RIVET               |

*Pilatus Aircraft, Ltd.: Pilatus PC-12,  
Pilatus PC-12/45,  
Pilatus PC-12/47 and  
Pilatus PC-12/47E*



**RAPCO**,inc.  
REPLACEMENT AIRCRAFT PARTS CO.  
[www.rapcoinc.com](http://www.rapcoinc.com)

Fuel Pumps  
Vacuum Pumps  
Filters & Gaskets  
Brake Components  
De-Ice Components  
...All FAA-PMA approved



### Rivets & Mounting Pins

RAPCO PN		Cleveland PN		Head Diameter	Shank Diameter	Overall Length
Current	Superseded	Current	Superseded			
<b>Rivets</b>						
RA105-00200	RA105-002	105-00200	105-2, 561	5/16	5/32	9/32
RA105-06700		105-06700		5/16	3/16	9/32
<b>Mounting Pin PN</b>						
RA177-00300	RABP001	177-00300	177-3	5/16	5/32	7/32
RA177-00400		177-00400	177-4	5/16	3/16	7/32
RA177-01600		177-01600	177-16	3/8	3/16	7/32

### Shims Insulators

RAPCO P/N	Cleveland PN
RA068-01100	068-01100
RA068-01600	068-01600
RA068-01700	068-01700
RA068-02700	068-02700
RA068-02800	068-02800
RA068-02900	068-02900
RA068-03000	068-03000
RA068-03100	068-03100
RA068-03300	068-03300
RA068-03900	068-03900
RA068-04100	068-04100
RA068-04600	068-04600

For reference only.

### Grease Seal - Molded

RAPCO PN	Cleveland PN
RA154-03000	154-03000

### Drive Keys

RAPCO PN	Cleveland PN
RA205-02900	205-02900
RA205-05201	205-05201

### Pressure Plates and Assemblies

RAPCO PN	Cleveland PN
RA063-01100	063-01100
RA063-01200	063-01200
RA063-01300	063-01300
RA063-02500	063-02500
RA063-30025	063-30025
RA073-02600	073-02600
RA073-08500	073-08500
RA073-08502	073-08502

### Wear Pads

Description	RAPCO PN	Cleveland PN
Wear Pad	RA109-00200	109-00200
Wear Pad	RA109-00201	109-00201
Wear Pad	RA109-01500	109-01500
Wear Pad	RA109-03000	109-03000

### Brake Overhaul Kit

Description	RAPCO PN	Cleveland PN	Minimum Wear
<b>PC-12 w/30-244 Brake Assy.</b>			
Brake Overhaul Kit	RA199-575A	199-575A	
Washer - Seal	RA095-01100	095-01100	
O-Ring	RA101-00700	101-00700	
O-Ring (MS58775-220)	RA101-02500	101-02500	
Rivet	RA105-02401	105-02401	
Rivet	RA105-08701	105-08701	
Wiper	RA107-03700	107-03700	
Wear Pad	RA109-03000	109-03000	Refer to: CM30-244
Rotor Disc	RA159-07400	159-07400	Refer to: CM30-244
Pressure Plate	RA063-08400	063-08400	
Pressure Plate Assembly	RA073-10100	073-10100	
Stationary Disc (Stator)	RA232-03500	232-03500	
Stationary Disc Assembly (Stator)	RA242-01800	242-01800	

For reference only.

70224

# REPLACEMENT Brake Lining Kits



## APPLICATION GUIDE

- \* **FAA-PMA Approved parts**
- \* **Replacements for Cleveland and McCauley Brake Assemblies**
- \* **Complete with all needed parts for one brake change**

***RAPCO,inc.***

**REPLACEMENT AIRCRAFT PARTS CO.**

445 Cardinal Lane

Hartland, Wisconsin 53029 USA

For a list of Distributors, please click on the document on the home screen or visit [www.rapcoinc.com](http://www.rapcoinc.com)





AIRCRAFT MFG / MODEL	BRAKE ASSY.	RAPCO KIT#
<b>AERO COMMANDER</b>		
100	30-56F	RA066-10500-4K
112	30-79	RA066-10500-4K
<b>BEECHCRAFT</b>		
Musketeer 23, 24 Series	30-75B	RA066-10500-4K
	30-79A	RA066-10500-4K
Debonair 33	30-1	RA066-11100-4K
	30-24	RA066-10600-8K
Bonanza 33	30-54	RA066-10500-8K
35 & 36	30-54A	RA066-10500-8K
A36, B36TC	30-54C	RA066-10500-8K
<b>BELLANCA</b>		
Citabria & Scout	30-19A	RA066-10600-4K
Champ	30-9	RA066-10600-4K
Scout	30-32B	RA066-10600-8K
Viking	30-52M	RA066-10500-8K
Aries	30-52	RA066-10500-8K
<b>CESSNA</b>		
120,140,170 (Conversion)	30-63A	RA066-10500-4K
150	30-63	RA066-10500-4K
150 (5.00 x 5 Wheels)	30-9	RA066-10600-4K
	30-40	RA066-10600-4K
152	C30018-5	RA066-30026-4K
172 (Before 1977)	30-56	RA066-10500-4K
	30-75A	RA066-10500-4K
172, R172 (1977 and after)	C30018	RA066-30026-4K
	C30018-2	RA066-30026-4K
	C30018-4	RA066-30026-4K
	C30018-6	RA066-30026-4K
172RG	C30018	RA066-30026-4K
	C30018-4	RA066-30026-4K
175	30-63	RA066-10500-4K
177	30-63	RA066-10500-4K
	30-75	RA066-10500-4K
177, 177RG (1976 and after)	C30018-4	RA066-30026-4K
	C30018-5	RA066-30026-4K
182 (Before 1976)	30-56	RA066-10500-4K
	30-75	RA066-10500-4K
182 (1976 and after)	C30018-4	RA066-30026-4K
	C30018-5	RA066-30026-4K
R182, TR182	C30018-3	RA066-30026-4K
	C30018-4	RA066-30026-4K
180	30-21	RA066-10600-8K
180, 185	30-52	RA066-10500-8K
188 (8.50 x 10 Wheels)	30-67A, C	RA066-10800-8K
188, 205	30-52	RA066-10500-8K
205, 205A	30-35	RA066-10600-8K
206, 207, 210	30-52	RA066-10500-8K
180, 185 (1975 and after)	D30118-5	RA066-30026-4K
	D30118-6	RA066-30026-4K
210	30-45	RA066-11100-4K
206, 210 (1976 and after)	D30118-3	RA066-30026-4K
	D30118-4	RA066-30026-4K
<b>EDO AIRE FLOATS</b>		
	30-51	RA066-10600-8K
<b>GRUMMAN AMERICAN</b>		
AA-1, AA-5	30-55B	RA066-10500-4K
	30-56B	RA066-10500-4K
G-164A AG CAT	30-67	RA066-10800-8K

AIRCRAFT MFG / MODEL	BRAKE ASSY.	RAPCO KIT#
<b>MAULE</b>		
M4, M5	30-63E	RA066-10500-4K
<b>MOONEY</b>		
M20	30-5	RA066-11100-4K
	30-56A	RA066-10500-4K
M10	30-63	RA066-10500-4K
M22 Mustang	30-56A	RA066-10500-4K
201, 231	30-56A	RA066-10500-4K
252	30-56D	RA066-10500-4K
<b>PARTENAVIA</b>		
P22C, P64B	30-18	RA066-10600-4K
P68C-160, P66T	30-55	RA066-10500-4K
P68S	30-61E	RA066-10500-8K
<b>PIPER</b>		
PA-11, -12, -16, -18	30-60	RA066-10600-4K
RA-20, -22	30-18	RA066-10600-4K
	30-41	RA066-10600-8K
	30-60	RA066-10600-4K
PA-23-150, -160	30-13	RA066-10600-8K
PA-24-180, -260	30-12	RA066-10600-8K
	30-41	RA066-10600-8K
PA-25-235 Pawnee	30-12	RA066-10600-8K
	30-41	RA066-10600-8K
PA-28-140, -150, -151, -161, -180	30-18	RA066-10600-4K
	30-34	RA066-11100-4K
	30-55	RA066-10500-4K
PA-28-235	30-55	RA066-10500-4K
PA-28-236	30-65	RA066-10500-8K
PA-28R-180, -200	30-41	RA066-10600-8K
	30-55	RA066-10500-4K
PA-28R-200, -201, -201T	30-55	RA066-10500-4K
PA-32-260, -300	30-65	RA066-10500-8K
<b>PITTS</b>		
S1, S2	30-9	RA066-10600-4K
<b>SOCATA</b>		
Ralleye	30-63J	RA066-10500-4K
TS9, 10, 20, 21	30-41B	RA066-10600-8K
<b>TAYLORCRAFT</b>		
F21, 21A	30-55	RA066-10500-4K
<b>VARGA</b>		
2150A, 2180	30-63E	RA065-10500-4K
<b>WACO</b>		
Meteor	30-63A	RA-66-10500-4K
<b>MISC. HOME BUILT</b>		
NOTE: Please refer to	30-9	RA066-10600-4K
Brake Assy. Number	30-63	RA066-10500-4K
For Reference Only		110520

# Pneumatic Filters

## FAA-PMA APPROVED REPLACEMENTS FOR AIRBORNE ASSEMBLIES

- \* **High Quality**
- \* **Non-restrictive Air Flow**
- \* **Avoid expensive instrument replacement**
- \* **Superior filtration with 0.3 micron media**
- \* **Inline & Central filters**
- \* **Meets Industry standards**

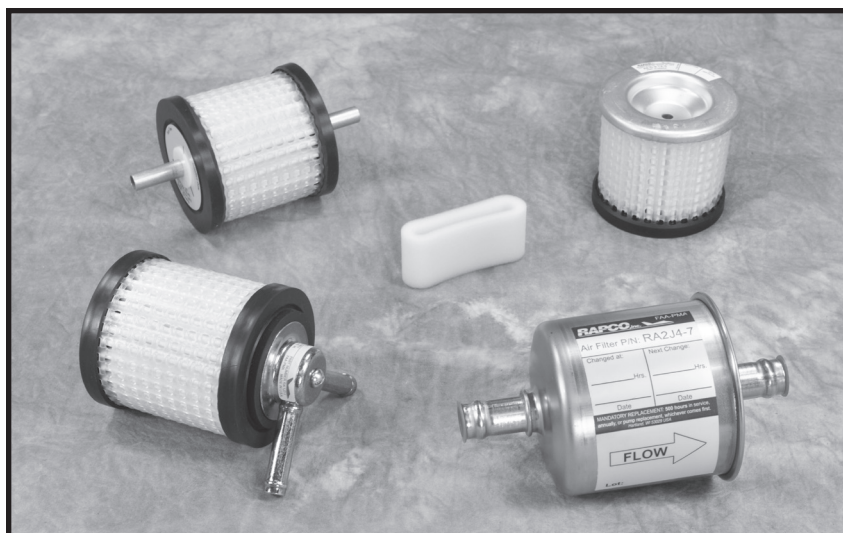

***RAPCO,inc.***

**REPLACEMENT AIRCRAFT PARTS CO.**

445 Cardinal Lane

Hartland, Wisconsin 53029 USA

For a list of Distributors, please click on the document on the home screen or visit [www.rapcoinc.com](http://www.rapcoinc.com)



# RECOMMENDED REPLACEMENT TIMES

■ **Vacuum Instrument Central Gyro Filters:**

Replace at least every 500 flight hours, annually, or at each pump change whichever comes first.

■ **Vacuum Relief and Pump Inlet Foam Garter Filters:**

Replace at least every 100 flight hours, annually, or at each pump change whichever comes first.







■ **Pressure / Vacuum System Inlet Filters:**

Replace at least every 100 flight hours, annually, or at each pump change whichever comes first.

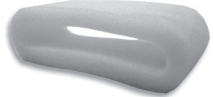
■ **Inline Filters for Pressure Systems:**

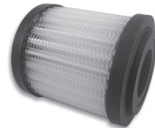
Replace at least every 500 flight hours, annually, or at pump change whichever comes first.

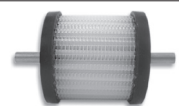
## IDENTIFICATION      PART NO.      DESCRIPTION

	RA1J7-1	Vacuum Instrument Central Gyro Air Filter assy: 0.3 Micron pleated paper element with two $\frac{3}{8}$ " beaded installation tubes. Overall - $3\frac{3}{4}$ " long x $2\frac{7}{8}$ " dia. RAD9-18-1 Element: $3\frac{1}{4}$ " long x $2\frac{7}{8}$ " dia.
	RA-B3-5-1	Garter Filter Element used on Airborne 133 & 2H3 series regulators and 1J1 series filter assemblies. Polyurethane foam 1" x $1\frac{3}{4}$ " diam.
	RA-D9-14-3	Replacement element used in Airborne 1J2-2 Inlet Filter. $2\frac{3}{16}$ " long x $2\frac{15}{16}$ " dia.
	RA-D-9-14-5	Replacement element used in Airborne 1J2 Series Inlet Filter (Except 1J2-2). $2\frac{5}{8}$ " long x $2\frac{15}{16}$ " dia.
	RA-D9-18-1	Replacement element used in RAPCO 1J7-1 Vacuum Instrument Central Gyro Air Filter Assembly. $3\frac{1}{4}$ " long x $2\frac{7}{8}$ " dia.
	RA2J4-4	Line Mounted Filter - Two $\frac{1}{2}$ " beaded tubes. Overall length $5\frac{3}{4}$ " long x $3\frac{1}{8}$ " dia.
	RA2J4-6	Line Mounted Filter - Two $\frac{5}{8}$ " beaded tubes. Overall length $6\frac{3}{4}$ " long x $3\frac{1}{8}$ " dia.
	RA2J4-7	Line Mounted Filter - Two $\frac{5}{8}$ " beaded tubes. Overall length $5\frac{1}{2}$ " long x $3\frac{1}{8}$ " dia.
	RA1J10-1	Line Mounted Filter - Two $\frac{3}{8}$ " non-beaded tubes. Overall length $5\frac{1}{4}$ " long x 3" dia.
	RA101-524009-0163	Rudder Boost Filter - Two $\frac{5}{8}$ " beaded tubes. Overall length $5\frac{1}{2}$ " long x $3\frac{1}{4}$ " dia.

## INTERCHANGEABILITY CHART

RAPCO P/N	Airborne P/N	Cessna P/N	Beech P/N	Piper P/N
RA1J4-4	1J4-4	200441 / 201442/ J-158444	92-301-126 92-301-127	460-857 / 460-888 460-866 / 560-689
RA1J4-6	1J4-6			
RA1J4-7	1J4-7			460-888
RA1J7-1	1J7-1			
RA1J10-1	1J10-1	C294502-0101		
RA-B3-5-1	B3-5-1	C482001-0202		751-815
RA-D9-14-3	D9-14-3		8398136-05-0H	
RA-D-9-14-5	D9-14-5	C294501-0103		
RA-D9-18-1	D9-18-1	C294502-0201/ J518317		757-899
RA101-524009-0163			101-524009-0163 101-524009-0161 101-524009-091	

# EXHAUST GASKETS

**FAA-PMA APPROVED REPLACEMENTS FOR  
CONTINENTAL & LYCOMING ENGINES**

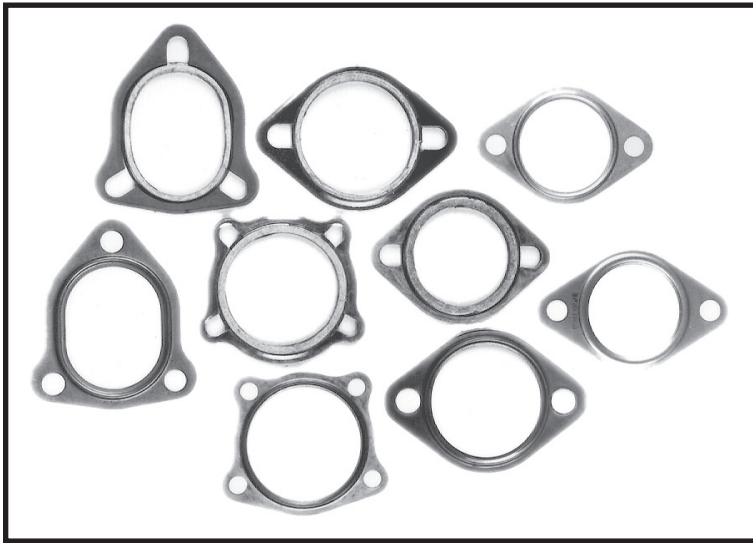

- \* **High quality**
- \* **Economical Stainless and Copper beaded Gaskets**
- \* **Extra Thick spiral wound style available - "Blow Proof"**

***RAPCO,inc.***

***REPLACEMENT AIRCRAFT PARTS CO.***





445 Cardinal Lane

Hartland, Wisconsin 53029 USA



For a list of Distributors, please click on the document on the home screen or visit [www.rapcoinc.com](http://www.rapcoinc.com)

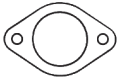

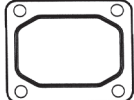
Style	RAPCO P/N	Use as Replacement For:			Use on These Engine Models
		OEM P/N	Airborne P/N	Superior P/N	

Solid		<b>RA630365</b>	630365	N/A	SA630365	IO-360-A, C, D, G, H, J, K
Spiral Wound		<b>RA970</b>	N/A	N/A	N/A	IO-360-A, C, D TSIO-360-A, B
Solid		<b>RA632837</b>	632837 21493	157	SA632837	A-65 A-75 C-85-12F C-90-8F, -12F, -14F, -16F E-165, E-185, E-225
Spiral Wound		<b>RA627429</b>	627429 652459	999	SA627429	O-200-A, B O-300-A, C, D O-470-A, E, J
Spiral Wound		<b>RA628260</b>	628260 652458	972	SA628260	O-470-B, G, K, L, M, P, R, S, U IO-470-D, U, V TSIO-470-B TSIO-520-B, C, D GTSIO-520-C, D
Turbo Charger Gasket		<b>RA636465</b>	636465	N/A	SA636465	TSIO-520: -A to -E, -G, -H, -J to N, -P, -R, -T, -U, -AE, -AF, -BB, -BE, -CE, -DB, -EB, -JB, -KB, -LB, -NB, -UB, -VB, -WB LTSIO-520-AE

**CONTINENTAL**

Solid		<b>RA75118</b>	75118 73720 67196 65321	160	N/A	O-290, O-320, IO-320, O-340, O-360, HO-360-B, IO-360-A, -B, -C, HIO-360-A, -B, -C, VO-435, TVO-435, GO-480, GSO-480, ISGO-480, O-540-A, -B, -E, -G, IO-540-A, -C, -D, -G, -J, -K, IGO-540-A, IGSO-540-A, IO-720-A
Spiral Wound		<b>RA77611</b>	77611	1000	SL77611	
Spiral Wound		<b>RALW15486</b>	LW15486	971	SL15486	TIO-541

**LYCOMING**

Solid		<b>RA985</b>	3503	N/A	N/A	R-985-AN-1, -3, -4, -6, -6B, -10, -12, -12B, -14B
-------	---	--------------	------	-----	-----	---

**PRAATT**

## INSTALLATION TIPS:

- Be sure that exhaust stack & cylinder flanges are flat
- Install solid gaskets with raised bead facing the exhaust stack flange -- These may be used in pairs with raised beads interlocked, if desired.
- Torque exhaust nuts to specifications from OEM manual -- Re-Torque after a hot run.



**RAPCO INC. Approved Replacement Parts for Continental, Lycoming, and Pratt & Whitney Engines**

**Exhaust Gasket, and Turbo Charger Gasket - FAA-PMA Approved  
Dry Air Pump Gasket, and Prop Governor Gasket - Standard Part Approved**

This Application Guide is to be used for reference only.

When selecting a part for installation consult the aircraft manufacturer's approved parts catalogue.

RAPCO FAA PMA approved part numbers are identified by an RA added to the beginning of the original equipment part number.

[Refer to the FAA-PMA Supplement for installation eligibility.](#)

Type Gasket	Application	RAPCO PN.	OEM	Airborne	Superior	Standard Part
Exhaust Gasket Solid Stainless Steel, 2 Hole	Continental IO-360-A, -C, -D, -G, -H, -J, -K	RA630365	630365		630365	
Exhaust Gasket Spiral Wound, 2 Hole	Continental IO-360-A, -C, -D, TSIO-360-A, -B	RA970				
Exhaust Gasket Solid Stainless Steel, 2 Hole	Continental A-65, A-75 C-85-12F, C-90-8F, -12F, -14F, -16F E-165, E-185, E-225 O-200-A, -B O-300-A, -C, -D O-470-A, -E, -J	RA632837	632837 21493 649428	157	SA632837	
Exhaust Gasket Spiral Wound, 2 Hole	Continental A-65, A-75 C-85-12F, C-90-8F, -12F, -14F, -16F E-165, E-185, E-225 O-200-A, -B O-300-A, -C, -D O-470-A, -E, -J	RA627429	627429 652459	999	SA627429	
Exhaust Gasket Spiral Wound, 4 Hole	Continental O-470-B, -G, -K, -L, -M, -P, -R, -S, -U IO-470-D, -U, -V TSIO-470-B TSIO-520-B, -C, -D GTSIO-520-C, -D	RA628260	628260 652458 629427  628216 537379	158	SA628260	
Turbo Charger Gasket Solid Stainless Steel, 4 Hole	Continental TSIO-520-A thru -E, -G, -H, -J to -N, P, -R, -T, -U, -AE, -AF, -BB, -BE, -CE, -DB, -EB, -JB, -KB, -LB, -NB, -UB, -VB, -WB LTSIO-520-AE	RA636465	636465		SA636465	
Exhaust Gasket Solid Copper, 2 Hole	Lycoming O-290, O-320, IO-320, O-340 O-360, HO-360-B, IO-360-A, -B, -C HIO360-A, -B, -C, VO-435, TVO-435, GO-480, GSO-480, ISGO-480, O-540-A, -B, -E, -G, IO-540-A, -C, -D, -G, -J, -K IGO-540-A, IGSO-540-A, IO-720-A	RA75118	LW-19296 75118 73720 67196 65321 61259	160		
Exhaust Gasket Spiral Wound, 2 Hole	Lycoming O-290, O-320, IO-320, O-340, O-360, HO-360-B, IO-360-A, -B, -C HIO360-A, -B, -C, VO-435, TVO-435, GO-480, GSO-480, ISGO-480 O-540-A, -B, -E, -G, IO-540-A, -C, -D, -G, -J, -K IGO-540-A, IGSO-540-A, IO-720-A	RA77611	77611		SL77611	
Exhaust Gasket Spiral Wound, 3 Hole	Lycoming TIO-541	RALW15486	LW15486	971	SL15486	
Exhaust Gasket Solid Stainless Steel, 3 Hole	Pratt & Whitney R-985-AN-1, -3, -4, -6, -6B, -10, -12, -12B, -14B	RA985	3503			
Dry Air Pump Mounting Flange Gasket	Continental and Lycoming engines with accessory mounting pad PN. AND20000	AS3491-01	653487 653152 8313			MS9134-01 AN4045-1 AS3491-01

**Installation Notes:** Make sure cylinder and exhaust stack flanges are flat. Check aircraft maintenance manual for proper installation.

In most cases solid gaskets should be installed in pairs with raised beads interlocked and facing away from the cylinder.

Also check maintenance manual for exhaust nut torque spec. Re-torque after a hot run.

For reference only. For installation eligibility refer to the FAA-PMA Supplement.

# FUEL PUMPS

## Electric

- New - FAA-PMA Approved with Warranty
- Overhauled – FAA and EASA Approved with Warranty and FAA Form 8130-3

RAPCO offers both new and overhauled electric fuel pumps and cartridges for replacement of Airborne and Dukes models.

New RAPCO fuel pumps are FAA-PMA approved as direct replacement assemblies. They incorporate modern design, materials, and manufacturing processes to provide a high quality fuel pump at a great price. They come with a full warranty.



Overhauled fuel pumps are produced in accordance with FAA process specifications by our Fleet Support Services division. FAA approved repair station, # NE5D64N with EASA certificate # 145.5230. Many of the upgraded components that go into our new pumps are also included in the production of overhauled assemblies, offering reliability and value backed by warranty.

***RAPCO,inc.***

***REPLACEMENT AIRCRAFT PARTS CO.***

445 Cardinal Lane

Hartland, Wisconsin 53029 USA

For a list of Distributors, please click on the document on the home screen or visit [www.rapcoinc.com](http://www.rapcoinc.com)



## Replacement

# Fuel Pumps

- \* FAA-approved process specification to overhaul fuel pumps
- \* Warranty same as OEM
- \* Worldwide Distribution
- \* Guaranteed pump performance
- \* Thoroughly tested

Fuel Pump Test Cell

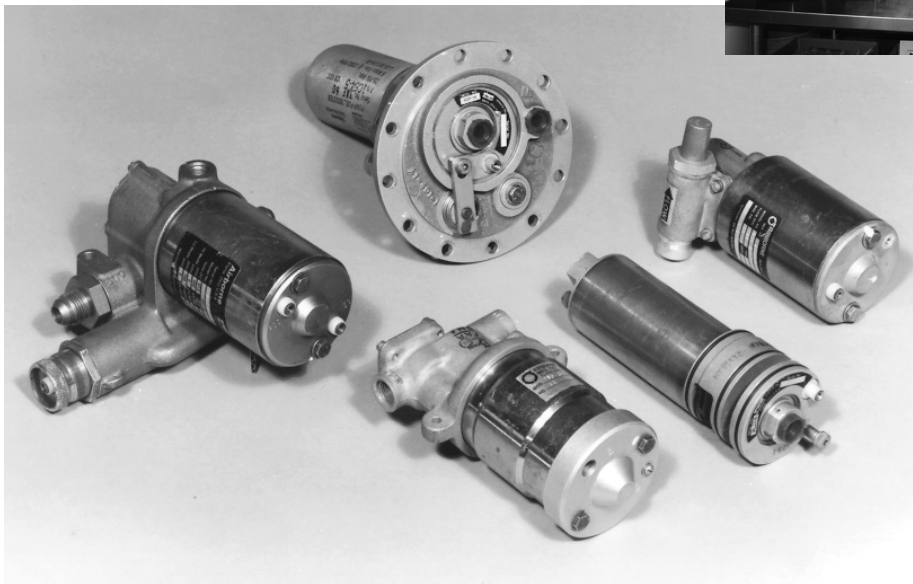

Overhauled - FAA Approved Fuel Pumps with Warranty and FAA Form 8130-3

New - FAA-PMA Approved Fuel Pumps with Warranty

Section 1: Airborne Fuel Pumps Overhauled by Fleet Support Services and RAPCO New Replacement pumps

Section 2: Dukes Fuel Pumps Overhauled by Fleet Support Services

This Application Guide is to be used for reference only. When selecting a part for installation consult the appropriate aircraft maintenance manual, parts catalogue, or equipment list for optional installations. To convert an original equipment part number to a RAPCO part number, add RA to the beginning of the number. Refer to the FAA-PMA Supplement for installation eligibility.

# **RAPCO,inc.**

**REPLACEMENT AIRCRAFT PARTS CO.**

445 Cardinal Lane

Hartland, Wisconsin 53029 USA

For a list of Distributors, please click on the document on the home screen or visit [www.rapcoinc.com](http://www.rapcoinc.com)



# FUEL PUMP APPLICATION GUIDE

## Section 1: Airborne - Overhauled Fuel Pump & Rapco New

### AIRCRAFT FUEL PUMP APPLICATION GUIDE

#### Electric Boost and Transfer Fuel Pumps and Cartridges

*Airborne, Dukes, and RAPCO, Overhauled Exchange or Customer Property Overhaul of by FSS  
FAA / EASA Dual Release on FAA Form 8130-3 Attached*

**RAPCO Inc. New Exchange Replacements for Airborne Fuel Pumps  
FAA-PMA Approved as a direct replacement part**

This Application Guide is to be used for reference only.

When selecting a part for installation consult the aircraft manufacturer's approved parts catalogue.

RAPCO Inc. brand new or overhaul replacement part numbers have RA added to the beginning of the original equipment PN.

[Refer to the FAA-PMA Supplement for installation eligibility.](#)

Section 1: Airborne and RAPCO Fuel Pumps OH Exchange by Fleet Support Services and RAPCO New Exchange replacement pumps

Section 2: Dukes Fuel Pumps Overhauled Exchange by Fleet Support Services

Section 1:

#### Airborne - Overhauled Exchange or Customer Property Overhaul Fuel Pumps

#### RAPCO - New Exchange or Overhaul Exchange Replacement Fuel Pumps

Aircraft Manufacturer & Model	Overhauled Airborne PN.	New or OH RAPCO	Aircraft Mfg. PN.
<b>Aero Commander</b> / Rockwell / Gulfstream / Twin Commander			
500B, 500S, 500V	1C15-1		630160-509
680T, 680V, 680 W, 681, 690, 690A, 690B	1D3-4		630309-503
690C, 690D, 695, 695A, 695B	3B7-4		630390-503
700	1C6-17 2B7-35 2B6-38 (SS to 2B7-35)		
<b>Aerospatiale</b> - see Eurocopter France			
<b>Aerostar</b> / Ted Smith Aerostar / Piper			
Aerostar 600, 601, 601P	2B6-6		481 813
PA-60-602P	2B6-73		481 833
PA-60-700P	2B6-75		481 836
<b>Agusta</b>			
A109, A109A, A109All , A109C, A109K2, A1090E, A119	2C35-3 (Cartridge only, see below) 1C27-11 (Cartridge for 2C35-3)	RA1C27-11	109-0611-53-1
<b>Beech</b> / Beechcraft / Raytheon / Hawker Beechcraft / Textron			
A36TC, B36TC	2B7-34		36-920001-603
56TC, A56TC, 58P, 58TC Baron, B60 Duke	1D1-6		60-389010-15
65, A65, 65B80, A65-8200,	1D1-8		50-389041-9
C90 King Air	1C12-1		50-389094-5
E90 King Air	1D2-13	RA1D2-13	50-380177-7



Aircraft Manufacturer & Model	Overhauled Airborne PN.	New or OH RAPCO	Aircraft Mfg. PN.
C90, C90A, C90GT, C90GTi, E90, 99, 99A, A99A, B99, C99, 100, A100, A100A, A100C, B100, 200, 200C, 200CT, 200T, B200, B200C, B200CT, B200CGT, B200GT	1D2-12	RA1D2-12	50-380177-5
300, 300LW, B300, B300C	1D2-13	RA1D2-13	50-380177-7
1900, 1900 (C-12), 1900C, 1900D, Airliner	1C64-5 (Also see below) 1C27-18 (Cartridge for 1C64-5)	RA1C27-18	118-389006-5
Model 400 Beechjet	1C7-15 1C7-9		45AS48015-2 45AS48015-3
MU-300	1C7-15 1C7-9		45AS48015-2 45AS48015-3
HS, 125-700A, BAE 125-800A Premier I	2B6-72 (APU Fuel Pump) 1C64-12 (Also see below) 1C27-21 (Cart. for 1C64-12)		118-389006-7
<b>Bell</b>			
205A 205A-1, 205A-1, 212, 412	2C12-1 w/ 2C27-3 Cartridge 1C64-1 w/ 2C27-3 Cartridge 2C27-3 (Cartridge for 1C64-1)	RA2C27-3	205-060-606-3 206-062-687-101
206B Jet Ranger  206B, 206L, 206L-1 206B, 206L, 206L-1 206L, 206L-1 Long Ranger 206B, 206L, 206L-1, 206L-3, 206L-4	1C38-1 (Also see below) 1C27-10 (Cartridge for 1C38-1) 1C35-1 (Also see Below) 1C27-10 (Cartridge for 1C35-1) 2C27-1 (Opt. Cartridge for 1C38-1) 1C36-1 (Also see Below) 2C27-1 (Cartridge for 1C36-1)	RA1C27-10  RA1C27-10 RA2C27-1	206-062-681-101  411523478-00 206-063-602-001 411523478-00
Gemini ST	1C45-7 (Cartridge only, see below) 1C45-6 (Cartridge for 1C45-7)		
407	1C36-4 (Cartridge only, see below) 1C27-10 Cartridge for 1C36-4	RA1C27-10	
407T	1C45-6		
412, 412EP, 412CF		RA2C27-3	
427	1C39-2 (Cartridge only see Below) 1C27-10 (Cartridge for 1C39-2)	RA1C27-10	427-366-104-101
<b>Bellanca</b>			
17-30A Viking w/ TCM Engine 17-31A Viking, 17-31ATC w/ Lycoming Engine	2B6-9 2B6-47		
<b>Bombardier</b> - see de Havilland			
<b>California Helicopter</b>			
S58T	3B7-4		
<b>CASA</b> - see EADS			
<b>Cessna / Textron</b>			
208, 208A Caravan	2C6-8		
310, 320, 340 (Tip Tank Models)	1C6-10		
401, 402, 414, 421 (Tip Tank Models)	1C6-10		

# FUEL PUMP APPLICATION GUIDE

Aircraft Manufacturer & Model	Overhauled Airborne PN.	New or OH RAPCO	Aircraft Mfg. PN.
402C Business Liner,	2B7-29		9910202-1 thru -4
404 Titan	2B7-51		9910202-1
406F Reims Caravan II	1C12-17		9910288-8
411	1C6-10		
414 (Aux wing tank)	1B5-8		
414A Chancellor	2B7-29 2B7-51 (Superceded to 2B7-29)		9910202-1 thru -4 9910202-1
421, 421A, 421B (Tip tank)	1C6-10		
421, 421A, 421B (Aux wing tank)	1B5-8		
421C	2B7-29 2B7-51 (Superceded to 2B7-29)		9910202-1 thru -4 9910202-1
425 Corsair/ Conquest I	2C6-3		
441 Conquest, Conquest II	1C12-17		9910288-8
500 Citation I, 550 Citation II, S550, 552 (T-47)	1C7-12		9912017-3
500 Citation I, 550 Citation II (British), 525 Citation Jet	1C7-13		9912017-4
560 Citation V	1C7-23		9912553-1
650 Citation III, VI, VII	1C56-2 (Cartridge only see below) 1C27-14 (Cart.for 1C56-2)	RA1C27-14	
<b>Daher / Socata / EADS</b>			
TBM 700	1B9-5		Z00.N6097727224
<b>de Havilland / Bombardier / Viking Air Limited</b>			
DHC-6-100, -200, -300 Twin Otter	1D2-17 1D2-14	RA1D2-17	C6SC1005-5
DHC-6-300 Twin Otter	2B7-1		
<b>Dornier - see Fairchild</b>			
<b>EADS / CASA</b>			
C-212	2C37-2 2C27-2 (Cartridge for 2C37-2))		AC520251
CN-235	1C12-34		AC510007B
<b>EADS - see Daher</b>			
<b>Embraer / Empresa Brasileira de Aeronautica SA.</b>			
EMB-110P1	2C37-1 (See below)		
P2 Bandeirante	2C27-2 (Cartridge for 2C37-1)		
EMB-120 Brasilia	1C7-17		
<b>Eurocopter Deutschland / M.B.B.</b>			
BO-105	1C64-2 (Also see Below) 2C27-3 (Cartridge for 1C64-2)		
BK-117, A1, A3, A4, B1, B2, C1	1C64-7 (Also see below)		
BO-105, CB, CBS	1C27-19 (Cartridge for 1C64-7)	RA1C27-19	
BO-105A, C, S, LS A1, LS A-3		RA2C27-3	



Aircraft Manufacturer & Model	Overhauled Airborne PN.	New or OH RAPCO	Aircraft Mfg. PN.
MBB-BK 117 A-1, A-3, A-4, B-1, B-2, C-1, C-2		RA1C27-5	
<b>Eurocopter France / Aerospatiale</b>			
AS-350D Astar	1C45-3 (Pump for 1C45-2)		
AS350B, B1, B2, BA, C, D, D1	1C45-5 (Pump for 1C45-4)		
SA360C Dauphin	1C44-1		
Twin Star, AS355E, AS335F	1C64-15 (See below)		
AS355F1, AS355F2, AS355N	1C27-20 (Cartridge for 1C64-15)	RA1C27-20	
SA365N/N1, AS365N2, AS365N3			
AS332L & L1, Super Puma	1C64-8 (Cartridge only see below)		
	1C27-20 (Cartridge for 1C64-8)	RA1C27-20	
<b>Fairchild / Swearingen</b>			
SA226-T, -AT, -TC, -T(B)	1C49-5 (3 pin connector)		
SA227-AC, -AT, -TT	1C49-3 (2 pin connector)		
Metro & Merlin	1D2-9 (2 pin connector)		
F27, F27A, B, F, G, J, M	1C42-1 (Also see Below)		
FH-227, B Thru -E	1C27-5 (Cartg. For 1C42-1)	RA1C27-5	
<b>Fairchild - Dornier</b>			
DO-228D-DO 28-D1	1C12-23		
DO-228-100, -101, -200, -201	1C12-32		
<b>Fokker</b>			
F27 Mark 50, 100-700	1C42-1 (Also see Below)		
	1C27-5 (Cart. for 1C42-1)	RA1C27-5	
F.27 Mark 100, 200, 300, 400, 500, 600, 700	1C27-19	RA1C27-19	
F-27, -27A, B, F, G, J, M, FH-227B, C, D, E			
<b>GAF - (Australia) Nomad</b>			
Nomad N22, N24	2B6-34		
Nomad N22B, N24A	2C6-2		
<b>Gulfstream - see Aero Commander</b>			
<b>Harbin</b>			
Y12-IV	2C37-5 (Cartridge only see below)		
	2C27-2 (Cart. for 2C37-5)		
<b>Hawker Beechcraft - see Beechcraft</b>			
<b>Hiller</b>			
UH-12D	2B6-52		
UH-1D, 12E	2B6-69 (Turbine)		
<b>Hughes - see McDonnell Douglas</b>			

# FUEL PUMP APPLICATION GUIDE

Aircraft Manufacturer & Model	Overhauled Airborne PN.	New or OH RAPCO	Aircraft Mfg. PN.
<b>Jetstream</b>			
Jetstream 3100	2C6-5		
Jetstream 3200 and 41	2C37-3, -4, -6 (Cart. Only see below) 2C27-4 (Cartridge for 2C37-3, -4, -6)		
<b>Kamen</b>			
KMAX 1200	1C64-9 (Cart. only see below) 2C27-3 (Cartridge for 1C64-9)		
Seasprite SH-2F, SH-26	1C64-1 1C64-6 (Cart. only see below) 2C27-3 (Cartridge for 1C64-6)		
<b>Machen</b>			
Aerostar, Bonanza Conversions	2B6-84		
<b>McDonnell Douglas / Hughes</b>			
369A, D, HE, HM, HS (500)	1C3-4		369A8143
500N, 600N		RA1C27-10	
<b>Mitsubishi</b>			
MU-2B-26A, -40, -60 (Except SN. 356 & 700)	1C12-3		035A948426-1
MU-300	1C7-9		45AS48015-3
(Beech Model 400)	1C7-15		45AS48015-2
<b>M.M.B - see Eurocopter Deutschland</b>			
<b>Piaggio</b>			
P-180	1C12-43		
<b>Piper</b>			
PA-31-350 Chieftain T1020	2B6-63 2B6-50 2B6-64 2B6-51		481 802  481 801
PA-31P Navajo	1C6-9		481 755
PA-31P-350 Mojave (4 mounting holes)	2C6-7		481 840
PA-31T, PA31T2, PA31T3, PA-42 Cheyenne	1C54-1		481 844
PA-32-300, PA32-301, PA-32R-301, PA32RT-301	1B5-6		481 708
PA-34-200 Seneca	1B5-6		481 708
PA-34-200 & PA34-200T SN. 34-7570309 & up	2B6-44		481 776
PA-34-220T SN.34-4480001 & up	2B6-86		461 724
PA-34-220T	2B6-88		461 749
PA-36-285 Pawnee Brave	2B6-16		481 748
PA-36-300 Pawnee Brave	2B6-36		481 768
PA-46-310P Malibu (6 mounting holes)	1C15-7		481 854
(Inline)	1B9-4		481875
PA-46-350P (Inline)	1B9-4		481875
(Submerged, with 6 mounting holes)	2C6-7		84100-003



Aircraft Manufacturer & Model	Overhauled Airborne PN.	New or OH RAPCO	Aircraft Mfg. PN.
PA-600, -700 Series - see Aerostar			
Raytheon - see Beechcraft			
Rockwell - see Aero Commander			
Socata see Daher			
<b>Soloy Hiller</b>			
UH-12D, 12E	2B6-69		
Ted Smith Aerostar - see Aerostar			
Textron - see Beech or Cessna			
Twin Commander - see Aero Commander			
<b>Viking Air Limited</b> - see de Havilland			
For reference only. Refer to the FAA-PMA Supplement for installation eligibility.			111924

# FUEL PUMP APPLICATION GUIDE

## Section 2: Dukes Overhauls

Section 2:

### Dukes - Fuel Pump Application Guide Overhauled Exchange or Customer Property Overhauls by FSS

Aircraft Manufacturer & Model	Dukes Overhaul PN.	Aircraft Mfg. PN.
<b>Cessna</b>		
R172K SN. R172000 thru R1722724	4140-00-17	C291504-0101
R172K SN. R1722725 & up	4140-00-15	C291504-0201
FR172E, G, H, J, K, up to SN. FR17200620	4140-00-17	C291504-0101
FR172K, up to SN. FR17200621 & up	4140-00-15	C291504-0201
R182/TR182 SN. R18200584 thru R18201628	4140-00-15	C291504-0201
177RG SN. 177RG0001 thru 177RG1266	4140-00-17	C291504-0101
177RG SN. 177RG1267 thru 177RG1366	4140-00-15	C291504-0201
F177RG SN. F177RG0063 thru F177RG0177	4140-00-17	C291504-0101
R182/TR182 SN. R18200584 thru R18201628	4140-00-15	C291504-0201
185, 185A, C, D, E SN.18502091 thru 18503458	4140-00-17	C291504-0101
A185E, A185F SN.18502091 thru 18503458	4140-00-17	C291504-0101
A185F SN.18503459 & up	4140-00-15	C291504-0201
188, A188, 188A, A188A, 188B, A188B	4140-00-17	C291504-0101
206	4140-00-17	C291504-0101
P206, P206A, P206B, P206C, P206D, P206E	4140-00-17	C291504-0101
TP206A, B, C, D, E	4140-00-17	C291504-0101
U206A, B, C, D, E, F, G	4140-00-17	C291504-0101
207, T207, 207A/T207A up to SN.20700414	4140-00-17	C291504-0101
207/T207 SN.20700228 & up, 207A/T207A	4140-00-15	C291504-0201
210-5, 210-5A, 210, 210A, B, C, D, E, F, G, H	4140-00-17	C291504-0101
210H, J, K, L, M, N, R	4140-00-15	C291504-0201
T210F, T210G, T210H	4140-00-17	C291504-0101
T210H, J, K, L, M, N, R	4140-00-15	C291504-0201
P210N, P210R	4140-00-15	C291504-0201
303	1515-00-1	C291504-0301
303 with SK303-43	1515-00-3	C291504-0302
310 Series (Wing Locker Tank)	4140-00-153	
320 Series (Wing Locker Tank)	4140-00-153	
335 (Wing Locker Tank)	4140-00-153	
336	4140-00-15	C291504-0201
337 Series	4140-00-15	C291504-0201
340 (Wing Locker Tank)	4140-00-153	
401 (Wing Locker Tank)	4140-00-153	
402, 402A, 402B (Wing Locker Tank)	4140-00-153	
414 (Wing Locker Tank)	4140-00-153	
421, 421A, 421B 421C (Wing Locker Tank)	4140-00-153	
<b>Gipsland Aeronautics</b>		
GA6	4140-00-17	
<b>Mooney - Be Sure to check Mooney AD status for proper Fuel Pump part number changes. Like part number cores must be returned for core credit.</b>		
M20D	4140-00-21A	
M20E, M20F, M20J (with filter) <a href="#">Click here to view AD 80-13-03</a>	4140-00-19A	610-153-501
M20E, M20F, M20J (no filter)	1499-00-19	
M20K	4140-00-19A	610-153-501
<b>Navion</b>		
H-Model	4140-00-17N	
<b>Piper</b>		
PA24-250 Comanche (Fuel Injected)	4140-00-218	
PA24-260 Comanche (Fuel Injected)	4140-00-218	

For reference only. Refer to the FAA-PMA Supplement for installation eligibility.

111424

# FUEL PUMP CROSS REFERENCE

## RAPCO INC. FUEL PUMP CROSS REFERENCE GUIDE - Electric

New - RAPCO FAA-PMA Approved Fuel Pumps. Overhauled - RAPCO FAA Approved Fuel Pumps come with FAA Form 8130-3

### RAPCO INC. FUEL PUMP CROSS REFERENCE GUIDE

Electric Fuel Pumps

**Airborne - Overhauled Exchange or Customer Property Overhaul**  
**RAPCO - New Exchange & Overhauled Exchange**  
**Dukes - Overhauled Exchange or Customer Property Overhaul**

FAA-PMA Approved

FAA, EASA, CAA Approved Data with FAA, EASA, CAA Dual Release FAA Form 8130-3

#### RAPCO - New Replacements for Airborne Fuel Pumps

RAPCO PN.	Airborne	Description
RA1C27-5	1C27-5	Fuel Pump Cartridge - New
RA1C27-10	1C27-10	Fuel Pump Cartridge - New
RA1C27-11	1C27-11	Fuel Pump Cartridge - New
RA1C27-14	1C27-14	Fuel Pump Cartridge - New
RA1C27-18	1C27-18	Fuel Pump Cartridge - New
RA1C27-19	1C27-19	Fuel Pump Cartridge - New
RA1C27-20	1C27-20	Fuel Pump Cartridge - New
RA1D2-12	1D2-12	Fuel Pump - New
RA1D2-13	1D2-13	Fuel Pump - New
RA1D2-17	1D2-17	Fuel Pump - New
RA2C27-1	2C27-1	Fuel Pump Cartridge - New
RA2C27-3	2C27-3	Fuel Pump Cartridge - New

#### RAPCO - Overhauled Exchange Replacements for Airborne Fuel Pumps

RAPCO PN.	Airborne	Description
RA1C27-5-OH	1C27-5	Fuel Pump Cartridge - Overhauled Exchange
RA1C27-10-OH	1C27-10	Fuel Pump Cartridge - Overhauled Exchange
RA1C27-11-OH	1C27-11	Fuel Pump Cartridge - Overhauled Exchange
RA1C27-14-OH	1C27-14	Fuel Pump Cartridge - Overhauled Exchange
RA1C27-18-OH	1C27-18	Fuel Pump Cartridge - Overhauled Exchange
RA1C27-19-OH	1C27-19	Fuel Pump Cartridge - Overhauled Exchange
RA1C27-20-OH	1C27-20	Fuel Pump Cartridge - Overhauled Exchange
RA1D2-12-OH	1D2-12	Fuel Pump - Overhauled Exchange
RA1D2-13-OH	1D2-13	Fuel Pump - Overhauled Exchange
RA1D2-17-OH	1D2-17	Fuel Pump - Overhauled Exchange
RA2C27-1-OH	2C27-1	Fuel Pump Cartridge - Overhauled Exchange
RA2C27-3-OH	2C27-3	Fuel Pump Cartridge - Overhauled Exchange

#### Airborne - Overhauled Exchange or Customer Property Overhaul, and RAPCO (RA) New & Overhaul Exchange

Airborne PN.	Beechcraft	Cessna	Piper	OEM	RAPCO	Description
1B5-6			481 708		1B5-6	Fuel Pump - Overhauled Exchange
1B5-8					1B5-8	Fuel Pump - Overhauled Exchange
1B9-4			481 875		1B9-4	Fuel Pump - Overhauled Exchange
1B9-5					1B9-5	Fuel Pump - Overhauled Exchange
1C3-4				369A8143	1C3-4	Fuel Pump - Overhauled Exchange
1C6-9			481 755		1C6-9	Fuel Pump - Overhauled Exchange
1C6-10					1C6-10	Fuel Pump - Overhauled Exchange
1C6-17					1C6-17	Fuel Pump - Customer Property Overhaul
1C7-3		9912017-1			1C7-3	Fuel Pump - Overhauled Exchange
1C7-9				45AS48015-3	1C7-9	Fuel Pump - Overhauled Exchange
1C7-12		9912017-3			1C7-12	Fuel Pump - Overhauled Exchange
1C7-13		9912017-4			1C7-13	Fuel Pump - Overhauled Exchange
1C7-15				45AS48015-2	1C7-15	Fuel Pump - Overhauled Exchange (PA-46-310P only)
1C7-17					1C7-17	Fuel Pump - Overhauled Exchange
1C7-23					1C7-23	Fuel Pump - Customer Property Overhaul
1C12-1	50-389094-5				1C12-1	Fuel Pump - Overhauled Exchange
1C12-3					1C12-3	Fuel Pump - Customer Property Overhaul
1C12-17		9910288-8			1C12-17	Fuel Pump - Customer Property Overhaul
1C12-23					1C12-23	Fuel Pump - Customer Property Overhaul
1C12-32					1C12-32	Fuel Pump - Customer Property Overhaul
1C12-34				AC510007B	1C12-34	Fuel Pump - Customer Property Overhaul
1C12-43					1C12-43	Fuel Pump - Customer Property Overhaul
1C15-1				630160-509	1C15-1	Fuel Pump - Overhauled Exchange
1C15-7			481 854		1C15-7	Fuel Pump - Overhauled Exchange
1C27-5					1C27-5	Fuel Pump Cartridge Overhaul Exchange
1C27-10				9518809	RA1C27-5	Fuel Pump Cartridge FAA-PMA New Exc. or OH. Exc.
1C27-11					1C27-10	Fuel Pump Cart. - OH Exc. (Replaces 1C27-4)
1C27-14					RA1C27-10	Fuel Pump Cartridge FAA-PMA New Exc. or OH. Exc.
1C27-18					1C27-11	Fuel Pump Cartridge Overhaul Exchange
1C27-19					RA1C27-11	Fuel Pump Cartridge FAA-PMA New Exc. or OH. Exc.
1C27-20					1C27-14	Fuel Pump Cart. - CPO. (Replaces 1C27-9, 1C27-12)
1C27-21					RA1C27-14	Fuel Pump Cartridge FAA-PMA New Exc. or OH. Exc.
1C33-1					1C27-18	Fuel Pump Cartridge - Overhaul Exchange
1C35-1					RA1C27-18	Fuel Pump Cartridge FAA-PMA New Exc. or OH. Exc.
1C36-1					1C27-19	Fuel Pump Cartridge - Customer Property Overhaul
1C38-1					RA1C27-19	Fuel Pump Cartridge FAA-PMA New Exc. or OH. Exc.
1C38-5					1C27-20	Fuel Pump Cartridge - Customer Property Overhaul
1C42-1					RA1C27-20	Fuel Pump Cartridge FAA-PMA New Exc. or OH. Exc.
					1C27-21	Fuel Pump Cartridge - Customer Property Overhaul
					1C33-1	Fuel Pump - Customer Property Overhaul
				206-062-673-001	1C35-1	Fuel Pump Assy. - OH Exc.w/1C27-10 Cart (SS by 1C38-1)
				206-063-602-001	1C36-1	Fuel Pump Assy. - OH Exc. w/ 2C27-1 Cart.
				206-062-681-101	1C38-1	Fuel Pump Assy. - OH Exc. 1C38-1/w 1C27-10 Cartridge
				206-062-681-105	1C38-5	Fuel Pump Assy. - CPO w/1C27-10 Cart (Replaces 1C38-1)
					1C42-1	Fuel Pump Assembly - Customer Property Overhaul

# FUEL PUMP CROSS REFERENCE

Airborne PN.	Beechcraft	Cessna	Piper	OEM	RAPCO	Description
1C44-1			C11BC0031		1C44-1	Fuel Pump - Customer Property Overhaul
1C44-2			C11BC0031		1C44-2	Fuel Pump - Customer Property Overhaul
1C45-3					1C45-3	Fuel Pump - Customer Property Overhaul
1C45-5					1C45-5	Fuel Pump - Customer Property Overhaul
1C45-6					1C45-6	Fuel Pump - Customer Property Overhaul
1C49-3					1C49-3	Fuel Pump - Overhauled Exchange (Replaced by 1C49-5)
1C49-5					1C49-5	Fuel Pump - Overhauled Exchange
1C54-1			481 844		1C54-1	Fuel Pump - Customer Property Overhaul
1C64-1				206-062-687-101	1C64-1	Fuel Pump Assembly - CPO w/ 2C27-3 Cart.
1C64-2					1C64-2	Fuel Pump Assembly - Customer Property Overhaul
1C64-5				118-389006-5	1C64-5	Fuel Pump Assembly - Customer Property Overhaul
1C64-7				117-64151-01, -03	1C64-7	Fuel Pump Assembly - Customer Property Overhaul
1C64-12				118-389006-7	1C64-12	Fuel Pump Assembly - Customer Property Overhaul
1D1-6	60-389010-15				1D1-6	Fuel Pump - Overhauled Exchange
1D1-8	50-389041-9				1D1-8	Fuel Pump - Overhauled Exchange
1D2-6					1D2-6	Fuel Pump - CPO (Replaced by RA1D2-12)
					RA1D2-12	Fuel Pump Cartridge FAA-PMA New Exc. or OH. Exc.
1D2-7					1D2-7	Fuel Pump - CPO (Replaced by RA1D2-13)
					RA1D2-13	Fuel Pump Cartridge FAA-PMA New Exc. or OH. Exc.
1D2-9					1D2-9	Fuel Pump - Overhauled Exchange
1D2-12	50-380177-5				1D2-12	Fuel Pump - Overhauled Exchange (Replaces 1D2-6)
					RA1D2-12	Fuel Pump Cartridge FAA-PMA New Exc. or OH. Exc.
1D2-13	50-380177-7				1D2-13	Fuel Pump - Overhauled Exchange
					RA1D2-13	Fuel Pump Cartridge FAA-PMA New Exc. or OH. Exc.
1D2-14					1D2-14	Fuel Pump - CPO (Replaced by RA1D2-17)
1D2-16					1D2-16	Fuel Pump - Customer Property Overhaul
1D2-17				C6SC1005-5	1D2-17	Fuel Pump - Overhauled Exchange
					RA1D2-17	Fuel Pump Cartridge FAA-PMA New Exc. or OH. Exc.
1D3-1					1D3-1	Fuel Pump - Customer Property Overhaul
1D3-4				630309-503	1D3-4	Fuel Pump - Overhauled Exchange
2B6-6			481 813		2B6-6	Fuel Pump - Customer Property Overhaul
2B6-9					2B6-9	Fuel Pump - Customer Property Overhaul
2B6-16			481 748		2B6-16	Fuel Pump - Overhauled Exchange
2B6-26			757 431		2B6-26	Fuel Pump - Customer Property Overhaul
2B6-28			481 756		2B6-28	Fuel Pump - CPO (Replaced by 2B6-44)
2B6-32			481 757		2B6-32	Fuel Pump - Customer Property Overhaul (SS by 2B6-63)
2B6-33			481 758		2B6-33	Fuel Pump - Customer Property Overhaul (SS by 2B6-64)
2B6-34					2B6-34	Fuel Pump - Customer Property Overhaul
2B6-36			481 768		2B6-36	Fuel Pump - Customer Property Overhaul
2B6-38					2B6-38	Fuel Pump - CPO (Replaced by 2B7-35)
2B6-44			481 776		2B6-44	Fuel Pump - Overhauled Exchange
2B6-47					2B6-47	Fuel Pump - Customer Property Overhaul
2B6-50			481 783		2B6-50	Fuel Pump - Customer Property Overhaul (SS by 2B6-63)
2B6-51			481 782		2B6-51	Fuel Pump - Customer Property Overhaul (SS by 2B6-64)
2B6-52					2B6-52	Fuel Pump - Customer Property Overhaul
2B6-63			481 802		2B6-63	Fuel Pump - Overhauled Exchange
2B6-64			481 801		2B6-64	Fuel Pump - Overhauled Exchange
2B6-69					2B6-69	Fuel Pump - Customer Property Overhaul
2B6-72					2B6-72	Fuel Pump - Overhauled Exchange (APU)
2B6-73			481 833		2B6-73	Fuel Pump - Overhauled Exchange
2B6-74					2B6-74	Fuel Pump - Customer Property Overhaul
2B6-75			481 836		2B6-75	Fuel Pump - Customer Property Overhaul
2B6-81				215T64111-2	2B6-81	Fuel Pump - Customer Property Overhaul
2B6-82					2B6-82	Fuel Pump - Customer Property Overhaul
2B6-84					2B6-84	Fuel Pump - Overhauled Exchange
2B6-86			461 724		2B6-86	Fuel Pump - Customer Property Overhaul
2B6-88			461 749		2B6-88	Fuel Pump - Customer Property Overhaul
2B7-1					2B7-1	Fuel Pump - Customer Property Overhaul
2B7-29		9910202-1, -2, -3, -4			2B7-29	Fuel Pump - Overhauled Exchange
2B7-34					2B7-34	Fuel Pump - Overhauled Exchange
2B7-35					2B7-35	Fuel Pump - Customer Property Overhaul
2B7-38					2B7-38	Fuel Pump - Customer Property Overhaul
2B7-44					2B7-44	Fuel Pump - Customer Property Overhaul
2B7-45					2B7-45	Fuel Pump - Customer Property Overhaul
2B7-51					2B7-51	Fuel Pump - Customer Property Overhaul
2C6-2					2C6-2	Fuel Pump - Customer Property Overhaul
2C6-3					2C6-3	Fuel Pump - Customer Property Overhaul
2C6-5					2C6-5	Fuel Pump - Customer Property Overhaul
2C6-7			481 840		2C6-7	Fuel Pump - Overhauled Exchange (4 hole base)
			84100-003			(6 hole base)
2C6-8					2C6-8	Fuel Pump - Customer Property Overhaul
2C7-1					2C7-1	Fuel Pump - Customer Property Overhaul
2C7-4					2C7-4	Fuel Pump - Customer Property Overhaul
2C12-1				205-060-606-3	2C12-1	Fuel Pump - Customer Property Overhaul
2C12-7					2C12-7	Fuel Pump - Customer Property Overhaul
2C27-1				411523487-00	2C27-1	Fuel Pump Cartridge - Overhauled Exchange
				411523487-00	RA2C27-1	Fuel Pump Cartridge FAA-PMA New Exc. or OH. Exc.
2C27-2				AC520251	2C27-2	Fuel Pump Cartridge - Customer Property Overhaul
2C27-3				118-389006-3	2C27-3	Fuel Pump Cartridge - Overhauled Exchange
					RA2C27-3	Fuel Pump Cartridge FAA-PMA New Exc. or OH. Exc.
2C27-4					2C27-4	Fuel Pump Cartridge - Customer Property Overhaul
2C37-1					2C37-1	Fuel Pump - Customer Property Overhaul
2C37-2					2C37-2	Fuel Pump - Customer Property Overhaul
3B7-1					3B7-1	Fuel Pump - Customer Property Overhaul
3B7-4				630390-503	3B7-4	Fuel Pump - Customer Property Overhaul
3B7-17					3B7-17	Fuel Pump - Customer Property Overhaul

For reference only. CPO = Customer Property Overhaul

61925



# Dukes Fuel Pump Cross Reference

## Dukes - Overhaul Exchange or Customer Property Overhaul

Dukes PN.	RAPCO	Description
1171-00-1	1171-00-1	Fuel Pump Overhaul Exchange
1184-00-1	1184-00-1	Fuel Pump Overhaul Exchange
1184-00-3	1184-00-3	Fuel Pump Overhaul Exchange
1296-00-1	1296-00-1	Fuel Pump Overhaul Exchange
1420-00-1	1420-00-1	Fuel Pump Overhaul Exchange
1429-00-1	1429-00-1	Fuel Pump Overhaul Exchange
1458-00-1	1458-00-1	Fuel Pump Overhaul Exchange
1471-00-3	1471-00-3	Fuel Pump Overhaul Exchange
1499-00-19	1499-00-19	Fuel Pump Overhaul Exchange
1499-00-21	1499-00-21	Fuel Pump Overhaul Exchange
1500-00-22	1500-00-22	Fuel Pump Customer Property OH
1500-00-35	1500-00-35	Fuel Pump Overhaul Exchange
1500-00-38	1500-00-38	Fuel Pump Overhaul Exchange
1500-00-65	1500-00-65	Fuel Pump Overhaul Exchange
1500-00-67	1500-00-67	Fuel Pump Overhaul Exchange
1515-00-1	1515-00-1	Fuel Pump Overhaul Exchange
1521-00-1	1521-00-1	Fuel Pump Overhaul Exchange
1521-00-3	1521-00-3	Fuel Pump Overhaul Exchange
1816-00-1	1816-00-1	Fuel Pump Overhaul Exchange
4140-00	4140-00	Fuel Pump Overhaul Exchange
4140-00-1	4140-00-1	Fuel Pump Overhaul Exchange
4140-00-7	4140-00-7	Fuel Pump Overhaul Exchange
4140-00-11	4140-00-11	Fuel Pump Overhaul Exchange
4140-00-15	4140-00-15	Fuel Pump Overhaul Exchange
4140-00-17	4140-00-17	Fuel Pump Overhaul Exchange
4140-00-17N	4140-00-17N	Fuel Pump Overhaul Exchange
4140-00-19A	4140-00-19A	Fuel Pump Overhaul Exchange
4140-00-21A	4140-00-21A	Fuel Pump Overhaul Exchange
4140-00-39	4140-00-39	Fuel Pump Overhaul Exchange
4140-00-47	4140-00-47	Fuel Pump Overhaul Exchange
4140-00-57	4140-00-57	Fuel Pump Overhaul Exchange
4140-00-103	4140-00-103	Fuel Pump Overhaul Exchange
4140-00-153	4140-00-153	Fuel Pump Overhaul Exchange
4140-00-191	4140-00-191	Fuel Pump Overhaul Exchange
4140-00-218	4140-00-218	Fuel Pump Overhaul Exchange
4140-00-220	4140-00-220	Fuel Pump Overhaul Exchange
4140-00-301	4140-00-301	Fuel Pump Overhaul Exchange
4140-00-311	4140-00-311	Fuel Pump Overhaul Exchange
4150-00	4150-00	Fuel Pump Customer Property OH
4150-00-1	4150-00-1	Fuel Pump Customer Property OH
4258-00-15	4258-00-15	Fuel Pump Overhaul Exchange
4404-00-7	4404-00-7	Fuel Pump Overhaul Exchange
4404-00-8	4404-00-8	Fuel Pump Overhaul Exchange
4613-00-1	4613-00-1	Fuel Pump Overhaul Exchange
4613-00-3	4613-00-3	Fuel Pump Overhaul Exchange
4613-00-5	4613-00-5	Fuel Pump Overhaul Exchange

For reference only.

111424

# TOW PIN

**RA60-820029-1**

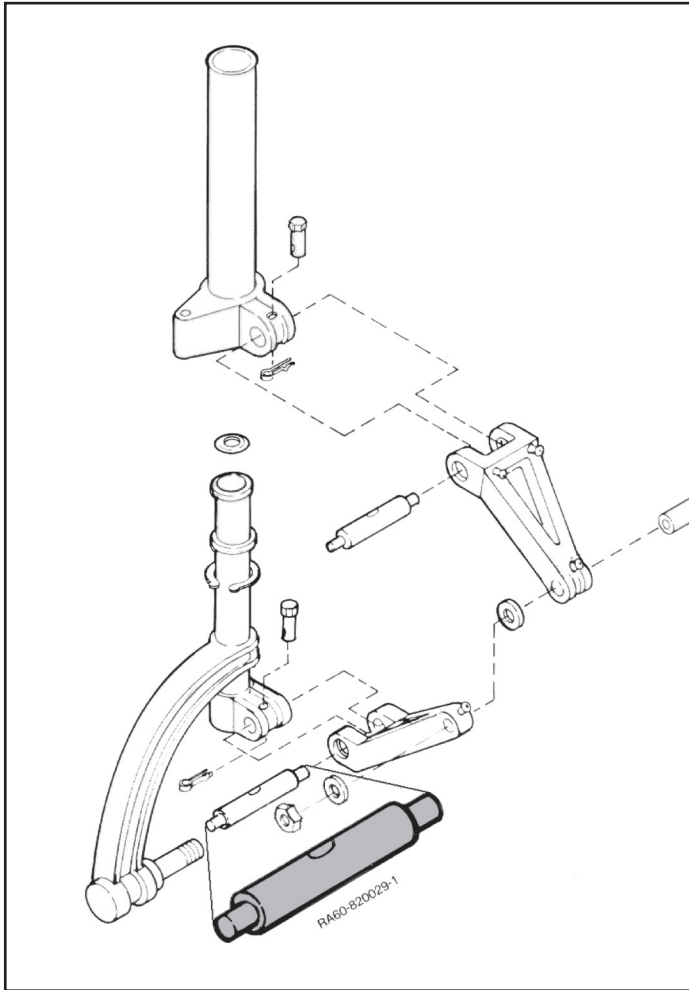

## FAA-PMA APPROVED INSTALLATION ELIGIBILITY

**Debonair:** 35-A33, 35-B33, 35-C33,  
35-C33A, E33, F33

**Bonanza:** G33, E33A, F33A, F33C,  
N35, P35, S35, V35, V35A,  
V35B, 36, A36, A36TC,  
B36TC

**Baron:** 95-55, 95-A55, 95-B55,  
95-C55, D55, E55, 56TC,  
A56TC, 58, 58TC, 58P

**Duke:** B60

- **Nickel Plated**
- **Heat Treated**

Designed to help protect against  
damage to nose gear during towing  
operations

Replaces: Beechcraft P/N:  
60-820029-1

***RAPCO, inc.***

**REPLACEMENT AIRCRAFT PARTS CO.**

445 Cardinal Lane

Hartland, Wisconsin 53029 USA

For a list of Distributors, please click on the document on the  
home screen or visit [www.rapcoinc.com](http://www.rapcoinc.com)





# Master Parts Cross Reference

## RAPCO INC. MASTER CROSS REFERENCE

Original Part Number	RAPCO Part Number	Description	Availability
164-00206	RA164-00206	Brake Disc	Normally Stocked
164-2F	RA164-00206	Brake Disc	Normally Stocked
754-650	RA164-00206	Brake Disc	Normally Stocked
164-00300	RA164-00300	Brake Disc	Normally Stocked
164-3	RA164-00300	Brake Disc	Normally Stocked
164-00400	RA164-00400	Brake Disc	Normally Stocked
164-4	RA164-00400	Brake Disc	Normally Stocked
164-00500	RA164-00500	Brake Disc	Normally Stocked
164-5	RA164-00500	Brake Disc	Normally Stocked
754-518	RA164-00500	Brake Disc	Normally Stocked
758-517	RA164-00500	Brake Disc	Normally Stocked
164-00700	RA164-00700	Brake Disc	Normally Stocked
164-7	RA164-00700	Brake Disc	Normally Stocked
164-00806	RA164-00806	Brake Disc	Normally Stocked
164-8F	RA164-00806	Brake Disc	Normally Stocked
164-00900	RA164-00900	Brake Disc	Normally Stocked
164-9	RA164-00900	Brake Disc	Normally Stocked
164-00100	RA164-00900	Brake Disc	Normally Stocked
164-001	RA164-00900	Brake Disc	Normally Stocked
754-530	RA164-00900	Brake Disc	Normally Stocked
164-01000	RA164-01000	Brake Disc	Normally Stocked
164-10	RA164-01000	Brake Disc	Normally Stocked
754-831	RA164-01000	Brake Disc	Normally Stocked
164-01300	RA164-01300	Brake Disc	Normally Stocked
164-13	RA164-01300	Brake Disc	Normally Stocked
754-528	RA164-01300	Brake Disc	Normally Stocked
164-01406	RA164-01406	Brake Disc	Normally Stocked
164-14F	RA164-01406	Brake Disc	Normally Stocked
164-01501	RA164-01501	Brake Disc	Normally Stocked
164-15A	RA164-01501	Brake Disc	Normally Stocked
164-01506	RA164-01506	Brake Disc	Normally Stocked
164-15F	RA164-01506	Brake Disc	Normally Stocked
164-01600	RA164-01600	Brake Disc	Normally Stocked
164-16	RA164-01600	Brake Disc	Normally Stocked
164-01700	RA164-01700	Brake Disc	Normally Stocked
164-17	RA164-01700	Brake Disc	Normally Stocked
754-617	RA164-01700	Brake Disc	Normally Stocked
164-01900	RA164-01900	Brake Disc	Normally Stocked
164-19	RA164-01900	Brake Disc	Normally Stocked
754-545	RA164-01900	Brake Disc	Normally Stocked
164-02000	RA164-02000	Brake Disc	Normally Stocked
164-20	RA164-02000	Brake Disc	Normally Stocked
754-535	RA164-02000	Brake Disc	Normally Stocked
164-02201	RA164-02201	Brake Disc	Normally Stocked
164-22A	RA164-02201	Brake Disc	Normally Stocked
754-554	RA164-02201	Brake Disc	Normally Stocked
164-02300	RA164-02300	Brake Disc	Normally Stocked
164-23	RA164-02300	Brake Disc	Normally Stocked
754-643	RA164-02300	Brake Disc	Normally Stocked
164-02504	RA164-02504	Brake Disc	Normally Stocked
164-02501	RA164-02504	Brake Disc	Normally Stocked
164-25A	RA164-02504	Brake Disc	Normally Stocked
164-02505	RA164-02505	Brake Disc	Normally Stocked
164-02503	RA164-02505	Brake Disc	Normally Stocked
164-02502	RA164-02505	Brake Disc	Normally Stocked
164-25C	RA164-02505	Brake Disc	Normally Stocked
164-25B	RA164-02505	Brake Disc	Normally Stocked
164-02601	RA164-02601	Brake Disc	Normally Stocked
164-26A	RA164-02601	Brake Disc	Normally Stocked
164-02706	RA164-02706	Brake Disc	Normally Stocked
164-27F	RA164-02706	Brake Disc	Normally Stocked
164-02707	RA164-02707	Brake Disc	Normally Stocked
164-27G	RA164-02707	Brake Disc	Normally Stocked
164-02800	RA164-02800	Brake Disc	Normally Stocked
164-28	RA164-02800	Brake Disc	Normally Stocked



# Master Parts Cross Reference

Original Part Number	RAPCO Part Number	Description	Availability
164-03006	RA164-03006	Brake Disc	Normally Stocked
164-30F	RA164-03006	Brake Disc	Normally Stocked
164-03106	RA164-03106	Brake Disc	Normally Stocked
164-31F	RA164-03106	Brake Disc	Normally Stocked
164-03206	RA164-03206	Brake Disc	Normally Stocked
164-32F	RA164-03206	Brake Disc	Normally Stocked
754-651	RA164-03206	Brake Disc	Normally Stocked
760-538	RA164-03206	Brake Disc	Normally Stocked
164-03300	RA164-03300	Brake Disc	Normally Stocked
164-33	RA164-03300	Brake Disc	Normally Stocked
754-562	RA164-03300	Brake Disc	Normally Stocked
164-03506	RA164-03506	Brake Disc	Normally Stocked
164-35F	RA164-03506	Brake Disc	Normally Stocked
164-03601	RA164-03601	Brake Disc	Normally Stocked
164-03600	RA164-03601	Brake Disc	Normally Stocked
164-36A	RA164-03601	Brake Disc	Normally Stocked
164-36	RA164-03601	Brake Disc	Normally Stocked
164-03906	RA164-03906	Brake Disc	Normally Stocked
164-03900	RA164-03906	Brake Disc	Normally Stocked
164-39F	RA164-03906	Brake Disc	Normally Stocked
164-39	RA164-03906	Brake Disc	Normally Stocked
164-04000	RA164-04000	Brake Disc	Normally Stocked
164-40	RA164-04000	Brake Disc	Normally Stocked
164-04300	RA164-04300	Brake Disc	Normally Stocked
164-43	RA164-04300	Brake Disc	Normally Stocked
164-04406	RA164-04406	Brake Disc	Normally Stocked
164-44F	RA164-04406	Brake Disc	Normally Stocked
164-04800	RA164-04800	Brake Disc	Normally Stocked
164-48	RA164-04800	Brake Disc	Normally Stocked
164-05006	RA164-05006	Brake Disc	Normally Stocked
164-50F	RA164-05006	Brake Disc	Normally Stocked
456-818	RA164-05006	Brake Disc	Normally Stocked
164-05000	RA164-05006	Brake Disc	Normally Stocked
164-50	RA164-05006	Brake Disc	Normally Stocked
164-05500	RA164-05500	Brake Disc	Normally Stocked
164-55	RA164-05500	Brake Disc	Normally Stocked
164-05700	RA164-05700	Brake Disc	Normally Stocked
164-57	RA164-05700	Brake Disc	Normally Stocked
754-612	RA164-05700	Brake Disc	Normally Stocked
164-05806	RA164-05806	Brake Disc	Normally Stocked
164-58F	RA164-05806	Brake Disc	Normally Stocked
164-06106	RA164-06106	Brake Disc	Normally Stocked
164-61F	RA164-06106	Brake Disc	Normally Stocked
164-06306	RA164-06306	Brake Disc	Normally Stocked
164-63F	RA164-06306	Brake Disc	Normally Stocked
164-06406	RA164-06406	Brake Disc	Normally Stocked
164-64F	RA164-06406	Brake Disc	Normally Stocked
164-06506	RA164-06506	Brake Disc	Normally Stocked
164-65F	RA164-06506	Brake Disc	Normally Stocked
164-06700	RA164-06700	Brake Disc	Normally Stocked
164-67	RA164-06700	Brake Disc	Normally Stocked
754-615	RA164-06700	Brake Disc	Normally Stocked
164-06900	RA164-06900	Brake Disc	Normally Stocked
164-69	RA164-06900	Brake Disc	Normally Stocked
164-07200	RA164-07200	Brake Disc	Normally Stocked
164-72	RA164-07200	Brake Disc	Normally Stocked
164-07400	RA164-07400	Brake Disc	Normally Stocked
164-74	RA164-07400	Brake Disc	Normally Stocked
164-07500	RA164-07500	Brake Disc	Normally Stocked
164-75	RA164-07500	Brake Disc	Normally Stocked
164-07700	RA164-07700	Brake Disc	Normally Stocked
164-77	RA164-07700	Brake Disc	Normally Stocked
754-642	RA164-07700	Brake Disc	Normally Stocked
164-07800	RA164-07800	Brake Disc	Normally Stocked
164-78	RA164-07800	Brake Disc	Normally Stocked
164-07906	RA164-07906	Brake Disc	Normally Stocked
164-79F	RA164-07906	Brake Disc	Normally Stocked
164-08100	RA164-08100	Brake Disc	Normally Stocked
164-81	RA164-08100	Brake Disc	Normally Stocked



# Master Parts Cross Reference

Original Part Number	RAPCO Part Number	Description	Availability
164-08200	RA164-08200	Brake Disc	Normally Stocked
164-82	RA164-08200	Brake Disc	Normally Stocked
164-08300	RA164-08300	Brake Disc	Normally Stocked
164-83	RA164-08300	Brake Disc	Normally Stocked
164-08406	RA164-08406	Brake Disc	Normally Stocked
164-84F	RA164-08406	Brake Disc	Normally Stocked
164-08500	RA164-08500	Brake Disc	Normally Stocked
164-85	RA164-08500	Brake Disc	Normally Stocked
164-09100	RA164-09100	Brake Disc	Normally Stocked
164-91	RA164-09100	Brake Disc	Normally Stocked
164-05500	RA164-09100	Brake Disc	Normally Stocked
164-55	RA164-09100	Brake Disc	Normally Stocked
164-09900	RA164-09900	Brake Disc	Normally Stocked
164-99	RA164-09900	Brake Disc	Normally Stocked
164-20206	RA164-20206	Brake Disc	Normally Stocked
164-202F	RA164-20206	Brake Disc	Normally Stocked
164-20306	RA164-20306	Brake Disc	Normally Stocked
164-203F	RA164-20306	Brake Disc	Normally Stocked
164-20500	RA164-20500	Brake Disc	Normally Stocked
164-205	RA164-20500	Brake Disc	Normally Stocked
164-20600	RA164-20600	Brake Disc	Normally Stocked
164-206	RA164-20600	Brake Disc	Normally Stocked
754-658	RA164-20600	Brake Disc	Normally Stocked
164-20700	RA164-20700	Brake Disc	Normally Stocked
164-207	RA164-20700	Brake Disc	Normally Stocked
164-20806	RA164-20806	Brake Disc	Normally Stocked
164-208F	RA164-20806	Brake Disc	Normally Stocked
164-20900	RA164-20900	Brake Disc	Normally Stocked
164-209	RA164-20900	Brake Disc	Normally Stocked
164-21000	RA164-21000	Brake Disc	Normally Stocked
164-210	RA164-21000	Brake Disc	Normally Stocked
164-21100	RA164-21100	Brake Disc	Normally Stocked
164-211	RA164-21100	Brake Disc	Normally Stocked
164-21200	RA164-21200	Brake Disc	Normally Stocked
164-212	RA164-21200	Brake Disc	Normally Stocked
164-21600	RA164-21600	Brake Disc	Normally Stocked
164-216	RA164-21600	Brake Disc	Normally Stocked
754-686	RA164-21600	Brake Disc	Normally Stocked
164-21900	RA164-21900	Brake Disc	Normally Stocked
164-219	RA164-21900	Brake Disc	Normally Stocked
164-22000	RA164-22000	Brake Disc	Normally Stocked
164-220	RA164-22000	Brake Disc	Normally Stocked
164-22201	RA164-22201	Brake Disc	Normally Stocked
164-222A	RA164-22201	Brake Disc	Normally Stocked
164-22202	RA164-22202	Brake Disc	Normally Stocked
164-222B	RA164-22202	Brake Disc	Normally Stocked
164-22400	RA164-22400	Brake Disc	Normally Stocked
164-224	RA164-22400	Brake Disc	Normally Stocked
164-22900	RA164-22900	Brake Disc	Normally Stocked
164-229	RA164-22900	Brake Disc	Normally Stocked
164-23000	RA164-23000	Brake Disc	Normally Stocked
164-230	RA164-23000	Brake Disc	Normally Stocked
164-23001	RA164-23001	Brake Disc	Normally Stocked
164-23002	RA164-23002	Brake Disc	Normally Stocked
164-24200	RA164-24200	Brake Disc	Normally Stocked
164-24400	RA164-24400	Brake Disc	Normally Stocked
164-30195	RA164-30195	Brake Disc	Normally Stocked
164-09300	RA164-30195	Brake Disc	Normally Stocked
164-93	RA164-30195	Brake Disc	Normally Stocked
B-30195	RA164-30195	Brake Disc	Normally Stocked
164-30388	RA164-30388	Brake Disc	Normally Stocked
164-09700	RA164-30388	Brake Disc	Normally Stocked
164-97	RA164-30388	Brake Disc	Normally Stocked
C-30388	RA164-30388	Brake Disc	Normally Stocked
164-30398	RA164-30398	Brake Disc	Normally Stocked
164-09600	RA164-30398	Brake Disc	Normally Stocked
164-96	RA164-30398	Brake Disc	Normally Stocked
C-30398	RA164-30398	Brake Disc	Normally Stocked
164-30414	RA164-30414	Brake Disc	Normally Stocked



# Master Parts Cross Reference

Original Part Number	RAPCO Part Number	Description	Availability
164-09500	RA164-30414	Brake Disc	Normally Stocked
164-95	RA164-30414	Brake Disc	Normally Stocked
C-30414	RA164-30414	Brake Disc	Normally Stocked
164-30440	RA164-30440	Brake Disc	Normally Stocked
164-09200	RA164-30440	Brake Disc	Normally Stocked
164-92	RA164-30440	Brake Disc	Normally Stocked
B-30440	RA164-30440	Brake Disc	Normally Stocked
164-30615-1	RA164-30615-1	Brake Disc	Normally Stocked
164-08800	RA164-30615-1	Brake Disc	Normally Stocked
164-88	RA164-30615-1	Brake Disc	Normally Stocked
C-30615-1	RA164-30615-1	Brake Disc	Normally Stocked
C-30615-4	RA164-30615-1	Brake Disc	Normally Stocked
164-30615-4	RA164-30615-1	Brake Disc	Normally Stocked
164-30615-2	RA164-30615-2	Brake Disc	Normally Stocked
164-08900	RA164-30615-2	Brake Disc	Normally Stocked
164-89	RA164-30615-2	Brake Disc	Normally Stocked
C-30615-2	RA164-30615-2	Brake Disc	Normally Stocked
164-30615-3	RA164-30615-3	Brake Disc	Normally Stocked
164-09000	RA164-30615-3	Brake Disc	Normally Stocked
164-90	RA164-30615-3	Brake Disc	Normally Stocked
C-30615-3	RA164-30615-3	Brake Disc	Normally Stocked
RA66-22	RA066-02200	Brake Lining	Normally Stocked
066-02200	RA066-02200	Brake Lining	Normally Stocked
66-22	RA066-02200	Brake Lining	Normally Stocked
RA66-33	RA066-03300	Brake Lining	Normally Stocked
066-03300	RA066-03300	Brake Lining	Normally Stocked
66-33	RA066-03300	Brake Lining	Normally Stocked
752-363	RA066-03300	Brake Lining	Normally Stocked
RA66-44	RA066-04400	Brake Lining	Normally Stocked
066-04400	RA066-04400	Brake Lining	Normally Stocked
66-44	RA066-04400	Brake Lining	Normally Stocked
RA66-62	RA066-06200	Brake Lining	Normally Stocked
066-06200	RA066-06200	Brake Lining	Normally Stocked
761-197	RA066-06200	Brake Lining	Normally Stocked
RA66-19	RA066-06200	Brake Lining	Normally Stocked
RA66-105M	RA066-06200	Brake Lining	Normally Stocked
66-62	RA066-06200	Brake Lining	Normally Stocked
066-01900	RA066-06200	Brake Lining	Normally Stocked
66-19	RA066-06200	Brake Lining	Normally Stocked
66-36	RA066-06200	Brake Lining	Normally Stocked
752-336	RA066-06200	Brake Lining	Normally Stocked
066-06400	RA066-06400	Brake Lining	Normally Stocked
66-64	RA066-06400	Brake Lining	Normally Stocked
RA66-65	RA066-06500	Brake Lining	Normally Stocked
066-06500	RA066-06500	Brake Lining	Normally Stocked
66-65	RA066-06500	Brake Lining	Normally Stocked
066-01500	RA066-06500	Brake Lining	Normally Stocked
66-15	RA066-06500	Brake Lining	Normally Stocked
RA66-15	RA066-06500	Brake Lining	Normally Stocked
752-335	RA066-06500	Brake Lining	Normally Stocked
RA66-66	RA066-06600	Brake Lining	Normally Stocked
066-06600	RA066-06600	Brake Lining	Normally Stocked
66-66	RA066-06600	Brake Lining	Normally Stocked
066-06700	RA066-06700	Brake Lining	Normally Stocked
RA66-68	RA066-06800	Brake Lining	Normally Stocked
066-06800	RA066-06800	Brake Lining	Normally Stocked
66-68	RA066-06800	Brake Lining	Normally Stocked
761-212	RA066-06800	Brake Lining	Normally Stocked
066-07300	RA066-07300	Brake Lining	Normally Stocked
66-73	RA066-07300	Brake Lining	Normally Stocked
066-09000	RA066-09000	Brake Lining	Normally Stocked
66-90	RA066-09000	Brake Lining	Normally Stocked
066-07900	RA066-09000	Brake Lining	Normally Stocked
66-79	RA066-09000	Brake Lining	Normally Stocked
066-09100	RA066-09100	Brake Lining	Normally Stocked
66-91	RA066-09100	Brake Lining	Normally Stocked
066-09200	RA066-09200	Brake Lining	Normally Stocked
66-92	RA066-09200	Brake Lining	Normally Stocked
066-09700	RA066-09700	Brake Lining	Normally Stocked



# Master Parts Cross Reference

Original Part Number	RAPCO Part Number	Description	Availability
66-97	RA066-09700	Brake Lining	Normally Stocked
066-10000	RA066-10000	Brake Lining	Normally Stocked
66-100	RA066-10000	Brake Lining	Normally Stocked
RA66-105	RA066-10500	Brake Lining	Normally Stocked
066-10500	RA066-10500	Brake Lining	Normally Stocked
066-10500	RA066-10500-4K	Brake Lining Kit	Normally Stocked
066-10500	RA066-10500-8K	Brake Lining Kit	Normally Stocked
66-105	RA066-10500	Brake Lining	Normally Stocked
066-09500	RA066-10500	Brake Lining	Normally Stocked
66-95	RA066-10500	Brake Lining	Normally Stocked
066-05500 (HD)	RA066-10500	Brake Lining	Normally Stocked
66-55 (HD)	RA066-10500	Brake Lining	Normally Stocked
066-03000	RA066-10500	Brake Lining	Normally Stocked
66-30	RA066-10500	Brake Lining	Normally Stocked
36-8001-23	RA066-10500	Brake Lining	Normally Stocked
66-30	RA066-10500	Brake Lining	Normally Stocked
752-342	RA066-10500	Brake Lining	Normally Stocked
RA66-106	RA066-10600	Brake Lining	Normally Stocked
066-10600	RA066-10600	Brake Lining	Normally Stocked
066-10600	RA066-10600-4K	Brake Lining Kit	Normally Stocked
066-10600	RA066-10600-8K	Brake Lining Kit	Normally Stocked
66-106	RA066-10600	Brake Lining	Normally Stocked
066-09400	RA066-10600	Brake Lining	Normally Stocked
66-94	RA066-10600	Brake Lining	Normally Stocked
066-05700 (HD)	RA066-10600	Brake Lining	Normally Stocked
66-57 (HD)	RA066-10600	Brake Lining	Normally Stocked
066-05600 (HD)	RA066-10600	Brake Lining	Normally Stocked
66-56 (HD)	RA066-10600	Brake Lining	Normally Stocked
066-00300	RA066-10600	Brake Lining	Normally Stocked
66-3	RA066-10600	Brake Lining	Normally Stocked
066-00200	RA066-10600	Brake Lining	Normally Stocked
66-2	RA066-10600	Brake Lining	Normally Stocked
3007	RA066-10600	Brake Lining	Normally Stocked
3006	RA066-10600	Brake Lining	Normally Stocked
752-309	RA066-10600	Brake Lining	Normally Stocked
752-308	RA066-10600	Brake Lining	Normally Stocked
RA66-108	RA066-10800	Brake Lining	Normally Stocked
066-10800	RA066-10800	Brake Lining	Normally Stocked
066-10800	RA066-10800-8K	Brake Lining Kit	Normally Stocked
066-10800	RA066-10800-12K	Brake Lining Kit	Normally Stocked
66-108	RA066-10800	Brake Lining	Normally Stocked
66-59 (HD)	RA066-10800	Brake Lining	Normally Stocked
066-03500	RA066-10800	Brake Lining	Normally Stocked
66-35	RA066-10800	Brake Lining	Normally Stocked
066-11000	RA066-11000	Brake Lining	Normally Stocked
66-110	RA066-11000	Brake Lining	Normally Stocked
66-3900	RA066-11000	Brake Lining	Normally Stocked
66-39	RA066-11000	Brake Lining	Normally Stocked
RA66-111	RA066-11100	Brake Lining	Normally Stocked
066-11100	RA066-11100	Brake Lining	Normally Stocked
066-11100	RA066-11100-4K	Brake Lining Kit	Normally Stocked
66-111	RA066-11100	Brake Lining	Normally Stocked
066-05800 (HD)	RA066-11100	Brake Lining	Normally Stocked
66-58 (HD)	RA066-11100	Brake Lining	Normally Stocked
066-00400	RA066-11100	Brake Lining	Normally Stocked
66-4	RA066-11100	Brake Lining	Normally Stocked
35-204	RA066-11100	Brake Lining	Normally Stocked
35-204	RA066-11100	Brake Lining	Normally Stocked
752-338	RA066-11100	Brake Lining	Normally Stocked
066-11200	RA066-11200	Brake Lining	Normally Stocked
066-11200	RA066-11200-4K	Brake Lining Kit	Normally Stocked
66-112	RA066-11200	Brake Lining	Normally Stocked
66-71 (HD)	RA066-11200	Brake Lining	Normally Stocked
066-13100	RA066-13100	Brake Lining	Normally Stocked
066-14100	RA066-14100	Brake Lining	Normally Stocked
066-14800	RA066-14800	Brake Lining	Normally Stocked
066-14800	RA066-14800	Brake Lining	Normally Stocked
066-15300	RA066-15300	Brake Lining	Normally Stocked
066-30026	RA066-30026	Brake Lining	Normally Stocked



# Master Parts Cross Reference

Original Part Number	RAPCO Part Number	Description	Availability
066-30026	RA066-30026-4K	Brake Lining Kit	Normally Stocked
066-30026	RA066-30026-8K	Brake Lining Kit	Normally Stocked
RA66-109	RA066-30026	Brake Lining	Normally Stocked
066-10900	RA066-30026	Brake Lining	Normally Stocked
66-109	RA066-30026	Brake Lining	Normally Stocked
066-08800 (HD)	RA066-30026	Brake Lining	Normally Stocked
66-88	RA066-30026	Brake Lining	Normally Stocked
066-08700 (HD)	RA066-30026	Brake Lining	Normally Stocked
66-87	RA066-30026	Brake Lining	Normally Stocked
B-30026	RA066-30026	Brake Lining	Normally Stocked
5009212	RA5009212	Brake Puck - Helicopter Rotor	Normally Stocked
4000365	RA5009212	Brake Puck - Helicopter Rotor	Normally Stocked
105-00200	RA105-00200	Rivet	Normally Stocked
105-2	RA105-00200	Rivet	Normally Stocked
561	RA105-00200	Rivet	Normally Stocked
156	RA105-00200	Rivet	Normally Stocked
105-02401	RA105-02401	Rivet	Normally Stocked
105-06700	RA105-06700	Rivet	Normally Stocked
105-08701	RA105-08701	Rivet	Normally Stocked
RABP001	RA177-00300	Mounting Pin	Normally Stocked
177-00300	RA177-00300	Mounting Pin	Normally Stocked
177-3	RA177-00300	Mounting Pin	Normally Stocked
177-00400	RA177-00400	Mounting Pin	Normally Stocked
177-4	RA177-00400	Mounting Pin	Normally Stocked
177-01600	RA177-01600	Mounting Pin	Normally Stocked
177-16	RA177-01600	Mounting Pin	Normally Stocked
068-01100	RA068-01100	Shims Insulators	Normally Stocked
068-01600	RA068-01600	Shims Insulators	Normally Stocked
068-01700	RA068-01700	Shims Insulators	Normally Stocked
068-02700	RA068-02700	Shims Insulators	Normally Stocked
068-02800	RA068-02800	Shims Insulators	Normally Stocked
068-02900	RA068-02900	Shims Insulators	Normally Stocked
068-03100	RA068-03100	Shims Insulators	Normally Stocked
068-03300	RA068-03300	Shims Insulators	Normally Stocked
068-04100	RA068-04100	Shims Insulators	Normally Stocked
068-04600	RA068-04600	Shims Insulators	Normally Stocked
063-01100	RA063-01100	Pressure Plates	Normally Stocked
063-01200	RA063-01200	Pressure Plates	Normally Stocked
063-01300	RA063-01300	Pressure Plates	Normally Stocked
063-02500	RA063-02500	Pressure Plates	Normally Stocked
063-30025	RA063-30025	Pressure Plates	Normally Stocked
073-02600	RA073-02600	Pressure Plate Assembly	Normally Stocked
073-08500	RA073-08500	Pressure Plate Assembly	Normally Stocked
073-08502	RA073-08502	Pressure Plate Assembly	Normally Stocked
109-00200	RA109-00200	Wear Pad	Normally Stocked
109-00201	RA109-00201	Wear Pad	Normally Stocked
109-01500	RA109-01500	Wear Pad	Normally Stocked
109-03000	RA109-03000	Wear Pad	Normally Stocked
205-02900	RA205-02900	Drive Key	Normally Stocked
205-05201	RA205-05201	Drive Key	Normally Stocked
154-03000	RA154-03000	Molded Grease Seal	Normally Stocked
199-579	RA825	Rivet Tool Kit	Normally Stocked
199-575A	RA199-575A	Brake Overhaul Kit (PC-12, 30-244)	Normally Stocked
095-01100	RA095-01100	Washer - Seal	Normally Stocked
101-00700	RA101-00700	O-Ring	Normally Stocked
101-02500	RA101-02500	O-Ring (MS58775-220)	Normally Stocked
107-03700	RA107-03700	Wiper	Normally Stocked
159-07400	RA159-07400	Rotor Disc	Normally Stocked
063-08400	RA063-08400	Pressure Plate	Normally Stocked
073-10100	RA073-10100	Pressure Plate Assembly	Normally Stocked
232-03500	RA232-03500	Stationary Disc (Stator)	Normally Stocked
242-01800	RA242-01800	Stationary Disc Assembly (Stator)	Normally Stocked
RA825AP	RA825AP	Anvil & Punch Replacement	Normally Stocked
3E1206-1	RA1306-1	De-ice Brush	Normally Stocked
753-427	RA1306-1	De-ice Brush	Normally Stocked
3E1206-2	RA1306-2	De-ice Brush	Normally Stocked
3E1206-3	RA1306-3	De-ice Brush	Normally Stocked
2E1260	RA1360	Nylon Spacer - Module Terminal	Normally Stocked
758-102	RA1360	Nylon Spacer - Module Terminal	Normally Stocked



# Master Parts Cross Reference

Original Part Number	RAPCO Part Number	Description	Availability
758-102	RA1360	Nylon Spacer - Module Terminal	Normally Stocked
3E1443-1	RA1543-1	De-ice Brush	Normally Stocked
578-175	RA1543-1	De-ice Brush	Normally Stocked
3E1443-2	RA1543-2	De-ice Brush	Normally Stocked
3E1443-4	RA1543-5	De-ice Brush Kit	Normally Stocked
RA1543-4	RA1543-5	De-ice Brush	Normally Stocked
3E1443-5	RA1543-5	De-ice Brush	Normally Stocked
3E1443-6	RA1543-7	De-ice Brush Kit - Rodded	Normally Stocked
RA1543-6	RA1543-7	De-ice Brush	Normally Stocked
3E1443-7	RA1543-7	De-ice Brush	Normally Stocked
2E1940-1	RA2040-1	Wear Strip - Brush Block	Normally Stocked
3E2011-1	RA2111U	Brush Module - Universal	Normally Stocked
3E2011-2	RA2111U	Brush Module - Universal	Normally Stocked
3E2011-3	RA2111U	Brush Module - Universal	Normally Stocked
3E2011-4	RA2111U	Brush Module - Universal	Normally Stocked
3E2011-5	RA2111U	Brush Module - Universal	Normally Stocked
3E2011-6	RA2111U	Brush Module - Universal	Normally Stocked
3E2011-8	RA2111U	Brush Module - Universal	Normally Stocked
3E2011-1	RA2111U-ROD	Brush Module - Universal	Normally Stocked
3E2011-2	RA2111U-ROD	Brush Module - Universal	Normally Stocked
3E2011-3	RA2111U-ROD	Brush Module - Universal	Normally Stocked
3E2011-4	RA2111U-ROD	Brush Module - Universal	Normally Stocked
3E2011-5	RA2111U-ROD	Brush Module - Universal	Normally Stocked
3E2011-10	RA2111U-ROD	Brush Module - Universal Rodded	Normally Stocked
3E2042-1	RA2142-1	Modular Brush Assembly	Normally Stocked
3E2042-2	RA2142-2	Modular Brush Assembly	Normally Stocked
3E2044-1	RA2144-1	Modular Brush Assembly	Normally Stocked
3E2044-2	RA2144-2	Modular Brush Assembly	Normally Stocked
3E2046-1	RA2146-1	Modular Brush Assembly	Normally Stocked
3E2046-2	RA2146-2	Modular Brush Assembly	Normally Stocked
3E2046-3	RA2146-3	Modular Brush Assembly	Normally Stocked
3E2062-1	RA2162-1	Modular Brush Assembly	Normally Stocked
3E2062-2	RA2162-2	Modular Brush Assembly	Normally Stocked
3E2071	RA2171	Modular Brush Assembly	Normally Stocked
3E2090-1	RA2190-1	Modular Brush Assembly	Normally Stocked
3E2090-2	RA2190-2	Modular Brush Assembly	Normally Stocked
3E2090-3	RA2190-3	Modular Brush Assembly	Normally Stocked
4E2218-3	RA2318-3	Spacer - Brush Module	Normally Stocked
4E2218-4	RA2318-4	Spacer - Brush Module	Normally Stocked
4E2218-5	RA2318-5	Spacer - Brush Module	Normally Stocked
4E2218-6	RA2318-6	Spacer - Brush Module	Normally Stocked
3E2326-1	RA2426-2	De-ice Brush Kit	Normally Stocked
RA2426-1	RA2426-2	De-ice Brush Kit	Normally Stocked
3E2326-2	RA2426-2	De-ice Brush Kit	Normally Stocked
3E2522-1	RA2620-1	De-ice Brush Kit	Normally Stocked
B-40012	RAB40012	Brush and Holder Assy.	Normally Stocked
B-40046	RAB40046	Brush and Holder Assy.	Normally Stocked
B-40189	RAB40189	Brush and Holder Assy.	Normally Stocked
B-40193	RAB40193	Brush and Holder Assy.	Normally Stocked
C-40256-1	RAC40256-1	Brush and Holder Assy.	Normally Stocked
C-40256-2	RAC40256-2	Brush and Holder Assy.	Normally Stocked
B-40332	RAB40332	Brush and Holder Assy.	Normally Stocked
C-40371-1	RAC40371-1	Brush and Holder Assy.	Normally Stocked
C-40371-2	RAC40371-2	Brush and Holder Assy.	Normally Stocked
C-40464-1	RAC-40464-1	Brush and Holder Assy.	Normally Stocked
C-40464-2	RAC-40464-2	Brush and Holder Assy.	Normally Stocked
C-40522-1	RAC-40522-1	Brush and Holder Assy.	Normally Stocked
C-40522-1	RAC-40522-1	Brush and Holder Assy.	Normally Stocked
3E1549	RA1649	Hub Extender - Wire	Normally Stocked
3E1556	RA1656	Hub Extender - Wire	Normally Stocked
4E1889-2	RA1989-2	Wire Harness	Normally Stocked
7021	RA1989-2	Wire Harness	Normally Stocked
4E1889-3	RA1989-3	Wire Harness	Normally Stocked
6959	RA1989-3	Wire Harness	Normally Stocked
4E1889-4	RA1989-4	Wire Harness	Normally Stocked
6871	RA1989-4	Wire Harness	Normally Stocked
4E1967-1	RA2067-1	Wire Harness Kit	Normally Stocked
6962	RA2067-1	Wire Harness Kit	Normally Stocked
4E1967-2	RA2067-2	Wire Harness Kit	Normally Stocked



# Master Parts Cross Reference

Original Part Number	RAPCO Part Number	Description	Availability
6963	RA2067-2	Wire Harness Kit	Normally Stocked
4E1967-3	RA2067-3	Wire Harness Kit	Normally Stocked
6964	RA2067-3	Wire Harness Kit	Normally Stocked
4E1967-4	RA2067-4	Wire Harness Kit	Normally Stocked
6965	RA2067-4	Wire Harness Kit	Normally Stocked
3E2017-4	RA2117-4	Wire Harness	Normally Stocked
6881	RA2117-4	Wire Harness	Normally Stocked
3E2017-8	RA-2117-8	Wire Harness	Normally Stocked
6951	RA-2117-8	Wire Harness	Normally Stocked
3E2050	RA2150	Wire Harness	Normally Stocked
6960	RA2150	Wire Harness	Normally Stocked
3E2050-2	RA2150-2	Wire Harness	Normally Stocked
6961	RA2150-2	Wire Harness	Normally Stocked
4E2071-1	RA-C165013-0602	Wire Harness	Normally Stocked
6260SW-1	RA-C165013-0602	Wire Harness	Normally Stocked
B-40276	RA-C165013-0602	Wire Harness	Normally Stocked
C165013-0602	RA-C165013-0602	Wire Harness	Normally Stocked
4E2071-2	RA2171-2	Wire Harness	Normally Stocked
6638	RA2171-2	Wire Harness	Normally Stocked
D-6206-1	RA2171-2	Wire Harness	Normally Stocked
4H2071-2	RA2171-2	Wire Harness	Normally Stocked
4E2071-3	RA-C165013-0604	Wire Harness	Normally Stocked
6479SW	RA-C165013-0604	Wire Harness	Normally Stocked
B-5051	RA-C165013-0604	Wire Harness	Normally Stocked
C165013-0604	RA-C165013-0604	Wire Harness	Normally Stocked
103767	RA-C165013-0604	Wire Harness	Normally Stocked
3E2092-1	RA2192-1	Wire Harness	Normally Stocked
7022	RA2192-1	Wire Harness	Normally Stocked
3H2092-1	RA2192-1	Wire Harness	Normally Stocked
3E2092-2	RA2192-2	Wire Harness	Normally Stocked
6887	RA2192-2	Wire Harness	Normally Stocked
3E2092-3	RA2192-3	Wire Harness	Normally Stocked
6952	RA2192-3	Wire Harness	Normally Stocked
3E2092-4	RA2192-4	Wire Harness	Normally Stocked
6834	RA2192-4	Wire Harness	Normally Stocked
3E2092-5	RA2192-5	Wire Harness	Normally Stocked
6953	RA2192-5	Wire Harness	Normally Stocked
3H2092-5	RA2192-5	Wire Harness	Normally Stocked
3E2092-6	RA2192-6	Wire Harness	Normally Stocked
6954	RA2192-6	Wire Harness	Normally Stocked
3E2094-1	RA2194-1	Wire Harness	Normally Stocked
6955	RA2194-1	Wire Harness	Normally Stocked
3E2094-2	RA2194-2	Wire Harness	Normally Stocked
6956	RA2194-2	Wire Harness	Normally Stocked
3E2094-3	RA2194-3	Wire Harness	Normally Stocked
6993	RA2194-3	Wire Harness	Normally Stocked
3E2360-4	RA2460-4	Wire Harness Kit w/ Clamps	Normally Stocked
7931-3E2360-4	RA2460-4HD	Wire Harness	Normally Stocked
3E2360-4	RA2460-4HD	Wire Harness	Normally Stocked
7931-3E2360-4	RA2460-4HD	Wire Harness	Normally Stocked
3E2369-1	RA2469-1	Wire Harness	Normally Stocked
6987	RA2469-1	Wire Harness	Normally Stocked
4E2369-2	RA2469-2	Wire Harness	Normally Stocked
6941	RA2469-2	Wire Harness	Normally Stocked
4E2526-1	RA2626-1	Wire Harness	Normally Stocked
6719SW	RA40330	Wire Harness	Normally Stocked
B-40330	RA40330	Wire Harness	Normally Stocked
103763	RA40330	Wire Harness	Normally Stocked
6992	RA40387	Wire Harness	Normally Stocked
B-40387	RA40387	Wire Harness	Normally Stocked
3E2293-1	RA40387	Wire Harness	Normally Stocked
B-40387	RA40387	Wire Harness	Normally Stocked
B-40531	RA40531	Wire Harness	Normally Stocked
103765	RA40531	Wire Harness	Normally Stocked
B-40585	RA40585	Wire Harness	Normally Stocked
103766	RA40585	Wire Harness	Normally Stocked
TA1720CSS4T	RATA1720SS4T	Wire Harness Clamp	Normally Stocked
7931-172004	RATA1720SS4T	Wire Harness Clamp	Normally Stocked
1C27-5	RA1C27-5	Fuel Pump Cartridge - New Exchange	Normally Stocked



# Master Parts Cross Reference

Original Part Number	RAPCO Part Number	Description	Availability
1C27-5	RA1C27-5-OH	Fuel Pump Cartridge - Overhauled Exchange	4 day
1C27-10	RA1C27-10	Fuel Pump Cartridge - New Exchange	Normally Stocked
1C27-10	RA1C27-10-OH	Fuel Pump Cartridge - Overhauled Exchange	4 day
1C27-11	RA1C27-11	Fuel Pump Cartridge - New Exchange	Normally Stocked
1C27-11	RA1C27-11-OH	Fuel Pump Cartridge - Overhauled Exchange	4 day
1C27-14	RA1C27-14	Fuel Pump Cartridge - New Exchange	Normally Stocked
1C27-14	RA1C27-14-OH	Fuel Pump Cartridge - Overhauled Exchange	4 day
1C27-18	RA1C27-18	Fuel Pump Cartridge - New Exchange	Normally Stocked
1C27-18	RA1C27-18-OH	Fuel Pump Cartridge - Overhauled Exchange	4 day
1C27-19	RA1C27-19	Fuel Pump Cartridge - New Exchange	Normally Stocked
1C27-19	RA1C27-19-OH	Fuel Pump Cartridge - Overhauled Exchange	4 day
1C27-20	RA1C27-20	Fuel Pump Cartridge - New Exchange	Normally Stocked
1C27-20	RA1C27-20-OH	Fuel Pump Cartridge - Overhauled Exchange	4 day
50-380177-5	RA1D2-12	Fuel Pump - New Exchange	Normally Stocked
1D2-12	RA1D2-12	Fuel Pump - New Exchange	Normally Stocked
1D2-12	RA1D2-12-OH	Fuel Pump - Overhauled Exchange	4 day
50-380177-7	RA1D2-13	Fuel Pump - New Exchange	Normally Stocked
1D2-13	RA1D2-13	Fuel Pump - New Exchange	Normally Stocked
1D2-13	RA1D2-13-OH	Fuel Pump - Overhauled Exchange	4 day
C6SC1005-5	RA1D2-17	Fuel Pump - New Exchange	Normally Stocked
1D2-17	RA1D2-17	Fuel Pump - New Exchange	Normally Stocked
1D2-17	RA1D2-17-OH	Fuel Pump - Overhauled Exchange	4 day
411523487-00	RA2C27-1	Fuel Pump Cartridge - New Exchange	Normally Stocked
2C27-1	RA2C27-1	Fuel Pump Cartridge - New Exchange	Normally Stocked
2C27-1	RA2C27-1-OH	Fuel Pump Cartridge - Overhauled Exchange	4 day
2C27-3	RA2C27-3	Fuel Pump Cartridge - New Exchange	Normally Stocked
2C27-3	RA2C27-3-OH	Fuel Pump Cartridge - Overhauled Exchange	4 day
1B5-6	1B5-6	Fuel Pump - Overhauled Exchange	4 day
481 708	1B5-6	Fuel Pump - Overhauled Exchange	4 day
1B5-8	1B5-8	Fuel Pump - Overhauled Exchange	4 day
481 875	1B9-4	Fuel Pump - Overhauled Exchange	4 day
1B9-4	1B9-4	Fuel Pump - Overhauled Exchange	4 day
1B9-5	1B9-5	Fuel Pump - Overhauled Exchange	4 day
1C3-4	1C3-4	Fuel Pump - Overhauled Exchange	4 day
1C6-1	1C6-1	Fuel Pump - CPO (Replaced by 1C6-10)	4 day
1C6-2	1C6-2	Fuel Pump - CPO (Replaced by 1C6-9)	4 day
481 755	1C6-9	Fuel Pump - Overhauled Exchange	4 day
1C6-9	1C6-9	Fuel Pump - Overhauled Exchange	4 day
J47023	1C6-10	Fuel Pump - Overhauled Exchange	4 day
1C6-10	1C6-10	Fuel Pump - Overhauled Exchange	4 day
1C6-17	1C6-17	Fuel Pump - Customer Property Overhaul	4 day
9912017-1	1C7-3	Fuel Pump - Overhauled Exchange	4 day
1C7-3	1C7-3	Fuel Pump - Overhauled Exchange	4 day
1C7-5	1C7-5	Fuel Pump - Overhauled Exchange	4 day
45AS48015-3	1C7-9	Fuel Pump - Overhauled Exchange	4 day
1C7-9	1C7-9	Fuel Pump - Overhauled Exchange	4 day
9912017-3	1C7-12	Fuel Pump - Overhauled Exchange	4 day
1C7-12	1C7-12	Fuel Pump - Overhauled Exchange	4 day
9912017-4	1C7-13	Fuel Pump - Overhauled Exchange	4 day
1C7-13	1C7-13	Fuel Pump - Overhauled Exchange	4 day
45AS48015-2	1C7-15	Fuel Pump - Overhauled Exchange	4 day
1C7-15	1C7-15	Fuel Pump - Overhauled Exchange	4 day
1C7-17	1C7-17	Fuel Pump - Overhauled Exchange	4 day
1C7-23	1C7-23	Fuel Pump - Customer Property Overhaul	4 day
50-38094-5	1C12-1	Fuel Pump - Overhauled Exchange	4 day
50-389094-5	1C12-1	Fuel Pump - Overhauled Exchange	4 day
1C12-1	1C12-1	Fuel Pump - Overhauled Exchange	4 day
1C12-3	1C12-3	Fuel Pump - Overhauled Exchange	4 day
9910288-8	1C12-17	Fuel Pump - Customer Property Overhaul	4 day
1C12-17	1C12-17	Fuel Pump - Customer Property Overhaul	4 day
1C12-23	1C12-23	Fuel Pump - Customer Property Overhaul	4 day
1C12-32	1C12-32	Fuel Pump - Customer Property Overhaul	4 day
AC510007B	1C12-34	Fuel Pump - Customer Property Overhaul	4 day
1C12-34	1C12-34	Fuel Pump - Customer Property Overhaul	4 day
1C12-43	1C12-43	Fuel Pump - Customer Property Overhaul	4 day
630160-509	1C15-1	Fuel Pump - Overhauled Exchange	4 day
1C15-1	1C15-1	Fuel Pump - Overhauled Exchange	4 day
481 854	1C15-7	Fuel Pump - Overhauled Exchange	4 day
1C15-7	1C15-7	Fuel Pump - Overhauled Exchange	4 day



# Master Parts Cross Reference

Original Part Number	RAPCO Part Number	Description	Availability
1C27-5	1C27-5	Fuel Pump Cartridge - Overhauled Exchange	4 day
1C27-10	1C27-10	Fuel Pump Cart. - OH Exc. (Replaces 1C27-4)	4 day
9518809	1C27-10	Fuel Pump Cart. - OH Exc. (Replaces 1C27-4)	4 day
1C27-11	1C27-11	Fuel Pump Cartridge - Overhauled Exchange	4 day
1C27-14	1C27-14	Fuel Pump Cart. - CPO. (Replaces 1C27-9, 1C27-12)	4 day
1C27-18	1C27-18	Fuel Pump Cartridge - Overhauled Exchange	4 day
9518810	1C27-18	Fuel Pump Cartridge - Overhauled Exchange	4 day
1C27-19	1C27-19	Fuel Pump Cartridge - Customer Property Overhaul	4 day
1C27-20	1C27-20	Fuel Pump Cartridge - Customer Property Overhaul	4 day
1C27-21	1C27-21	Fuel Pump Cartridge - Customer Property Overhaul	4 day
1C33-1	1C33-1	Fuel Pump - Customer Property Overhaul	4 day
1C35-1	1C35-1	Fuel Pump Assy. - OH Exc/w1C27-10 Cart. (SS by 1C38-1)	4 day
206-063-602-001	1C36-1	Fuel Pump Assy. - OH Exc./w 2C27-1 Carts.	4 day
1C36-1	1C36-1	Fuel Pump Assy. - OH Exc./w 2C27-1 Carts.	4 day
206-062-681-101	1C38-1	Fuel Pump Assy. - OH Exc./w 1C27-10 Cart.	4 day
1C38-1	1C38-1	Fuel Pump Assy. - OH Exc./w 1C27-10 Cart.	4 day
1C38-5	1C38-5	Fuel Pump - CPO 1C38-5 w/1C27-10 Cart(Replaces1C38-1)	4 day
1C42-1	1C42-1	Fuel Pump Cartridge - Customer Property Overhaul	4 day
C11BC0031	1C44-1	Fuel Pump Cartridge - Customer Property Overhaul	4 day
1C44-1	1C44-1	Fuel Pump Cartridge - Customer Property Overhaul	4 day
C11BC0031	1C44-2	Fuel Pump Cartridge - Customer Property Overhaul	4 day
1C44-2	1C44-2	Fuel Pump Cartridge - Customer Property Overhaul	4 day
1C45-3	1C45-3	Fuel Pump Cartridge - Customer Property Overhaul	4 day
1C45-5	1C45-5	Fuel Pump Cartridge - Customer Property Overhaul	4 day
1C45-6	1C45-6	Fuel Pump Cartridge - Customer Property Overhaul	4 day
1C49-3	1C49-3	Fuel Pump - Overhauled Exchange (Replaced by 1C49-5)	4 day
1C49-5	1C49-5	Fuel Pump - Overhauled Exchange	4 day
481 844	1C54-1	Fuel Pump - Customer Property Overhaul	4 day
1C54-1	1C54-1	Fuel Pump - Customer Property Overhaul	4 day
206-062-687-101	1C64-1	Fuel Pump - Overhaul Exchange w/ 2C27-3 Cartridge	4 day
1C64-1	1C64-1	Fuel Pump - Overhaul Exchange w/ 2C27-3 Cartridge	4 day
1C64-2	1C64-2	Fuel Pump - Overhauled Exchange	4 day
118-389006-5	1C64-5	Fuel Pump Assembly - Customer Property Overhaul	4 day
1C64-5	1C64-5	Fuel Pump Assembly - Customer Property Overhaul	4 day
1C64-7	1C64-7	Fuel Pump Assembly - Customer Property Overhaul	4 day
1C64-7	1C64-7	Fuel Pump Assembly - Customer Property Overhaul	4 day
1C64-12	1C64-12	Fuel Pump Assembly - Customer Property Overhaul	4 day
118-389006-7	1C64-12	Fuel Pump Assembly - Customer Property Overhaul	4 day
60-389010-15	1D1-6	Fuel Pump - Overhauled Exchange	4 day
1D1-6	1D1-6	Fuel Pump - Overhauled Exchange	4 day
50-389041-9	1D1-8	Fuel Pump - Overhauled Exchange	4 day
1D1-8	1D1-8	Fuel Pump - Overhauled Exchange	4 day
1D2-6	1D2-6	Fuel Pump - CPO (Replaced by RA1D2-12)	4 day
1D2-7	1D2-7	Fuel Pump - CPO (Replaced by RA1D2-13)	4 day
1D2-9	1D2-9	Fuel Pump - Overhauled Exchange	4 day
50-380177-5	1D2-12	Fuel Pump - Overhauled Exchange	4 day
1D2-12	1D2-12	Fuel Pump - Overhauled Exchange	4 day
1D2-13	1D2-13	Fuel Pump - Overhauled Exchange	4 day
1D2-14	1D2-14	Fuel Pump - OH Exc. (Replaced by RA1D2-17)	4 day
1D2-16	1D2-16	Fuel Pump - OH Exc. (Replaced by RA1D2-12)	4 day
C6SC1005-5	1D2-17	Fuel Pump - Overhauled Exchange	4 day
1D2-17	1D2-17	Fuel Pump - Overhauled Exchange	4 day
481 737	1D3-1	Fuel Pump - Customer Property Overhaul	4 day
1D3-1	1D3-1	Fuel Pump - Customer Property Overhaul	4 day
630309-503	1D3-4	Fuel Pump - Overhauled Exchange	4 day
481 813	2B6-6	Fuel Pump - Overhauled Exchange	4 day
2B6-9	2B6-9	Fuel Pump - Overhauled Exchange	4 day
2B6-16	2B6-16	Fuel Pump - Overhauled Exchange	4 day
2B6-26	2B6-26	Fuel Pump - Customer Property Overhaul	4 day
2B6-28	2B6-28	Fuel Pump - Overhauled Exchange (Replaced by 2B6-44)	4 day
481 757	2B6-32	Fuel Pump - Customer Property Overhaul (SS by 2B6-63)	4 day
2B6-32	2B6-32	Fuel Pump - Customer Property Overhaul (SS by 2B6-63)	4 day
481 758	2B6-33	Fuel Pump - Customer Property Overhaul SS by 2B6-64)	4 day
2B6-33	2B6-33	Fuel Pump - Customer Property Overhaul	4 day
2B6-34	2B6-34	Fuel Pump - Overhauled Exchange	4 day
481 786	2B6-36	Fuel Pump - Overhauled Exchange	4 day
2B6-36	2B6-36	Fuel Pump - Overhauled Exchange	4 day
2B6-38	2B6-38	Fuel Pump - Overhauled Exchange (Replaced by 2B7-35)	4 day
481 708	2B6-44	Fuel Pump - Overhauled Exchange	4 day



# Master Parts Cross Reference

Original Part Number	RAPCO Part Number	Description	Availability
2B6-44	2B6-44	Fuel Pump - Overhauled Exchange	4 day
481 776	2B6-44	Fuel Pump - Overhauled Exchange	4 day
2B6-44	2B6-44	Fuel Pump - Overhauled Exchange	4 day
2B6-47	2B6-47	Fuel Pump - Overhauled Exchange	4 day
481 783	2B6-50	Fuel Pump - Customer Property Overhaul (SS by 2B6-63)	4 Day
2B6-50	2B6-50	Fuel Pump - Customer Property Overhaul (SS by 2B6-63)	4 Day
481 702	2B6-51	Fuel Pump - Customer Property Overhaul (SS by 2B6-64)	4 day
2B6-51	2B6-51	Fuel Pump - Customer Property Overhaul (SS by 2B6-64)	4 day
2B6-52	2B6-52	Fuel Pump - Customer Property Overhaul	4 day
481 802	2B6-63	Fuel Pump - Overhauled Exchange	4 day
2B6-63	2B6-63	Fuel Pump - Overhauled Exchange	4 day
481 801	2B6-64	Fuel Pump - Overhauled Exchange	4 day
2B6-64	2B6-64	Fuel Pump - Overhauled Exchange	4 day
2B6-69	2B6-69	Fuel Pump - Overhauled Exchange	4 day
2B6-72	2B6-72	Fuel Pump - Overhauled Exchange (APU)	4 day
481 833	2B6-73	Fuel Pump - Overhauled Exchange	4 day
2B6-73	2B6-73	Fuel Pump - Overhauled Exchange	4 day
2B6-74	2B6-74	Fuel Pump - Overhauled Exchange	4 day
481 836	2B6-75	Fuel Pump - Overhauled Exchange	4 day
2B6-75	2B6-75	Fuel Pump - Overhauled Exchange	4 day
2B6-81	2B6-81	Fuel Pump - Customer Property Overhaul	4 day
2B6-82	2B6-82	Fuel Pump - Customer Property Overhaul	4 day
2B6-84	2B6-84	Fuel Pump - Overhauled Exchange	4 day
461 724	2B6-86	Fuel Pump - Customer Property Overhaul	4 day
2B6-86	2B6-86	Fuel Pump - Customer Property Overhaul	4 day
2B6-88	2B6-88	Fuel Pump - Customer Property Overhaul	4 day
2B7-1	2B7-1	Fuel Pump - Customer Property Overhaul	4 day
2B7-29	2B7-29	Fuel Pump - Overhauled Exchange	4 day
9910202-1	2B7-29	Fuel Pump - Overhauled Exchange	4 day
9910202-2	2B7-29	Fuel Pump - Overhauled Exchange	4 day
9910202-3	2B7-29	Fuel Pump - Overhauled Exchange	4 day
9910202-4	2B7-29	Fuel Pump - Overhauled Exchange	4 day
2B7-34	2B7-34	Fuel Pump - Overhauled Exchange	4 day
2B7-35	2B7-35	Fuel Pump - Customer Property Overhaul	4 day
2B7-38	2B7-38	Fuel Pump - Customer Property Overhaul	4 day
2B7-44	2B7-44	Fuel Pump - Customer Property Overhaul	4 day
2B7-45	2B7-45	Fuel Pump - Customer Property Overhaul	4 day
2B7-51	2B7-51	Fuel Pump - Customer Property Overhaul	4 day
2C6-2	2C6-2	Fuel Pump - Overhauled Exchange	4 day
2C6-3	2C6-3	Fuel Pump - Overhauled Exchange	4 day
2C6-5	2C6-5	Fuel Pump - Customer Property Overhaul	4 day
481 840	2C6-7	Fuel Pump - Overhauled Exchange	4 day
2C6-8	2C6-8	Fuel Pump - Customer Property Overhaul	4 day
2C7-1	2C7-1	Fuel Pump - Customer Property Overhaul	4 day
2C7-4	2C7-4	Fuel Pump - Customer Property Overhaul	4 day
205-060-606-3	2C12-1	Fuel Pump - Customer Property Overhaul	4 day
2C12-1	2C12-1	Fuel Pump - Customer Property Overhaul	4 day
2C12-7	2C12-7	Fuel Pump - Customer Property Overhaul	4 day
411523487-00	2C27-1	Fuel Pump Cartridge - Overhauled Exchange	4 day
2C27-1	2C27-1	Fuel Pump Cartridge - Overhauled Exchange	4 day
2C27-2	2C27-2	Fuel Pump Cartridge - Customer Property Overhaul	4 day
AC520251	2C27-2	Fuel Pump Cartridge - Customer Property Overhaul	4 day
2C27-3	2C27-3	Fuel Pump Cartridge - Overhauled Exchange	4 day
118-389006-3	2C27-3	Fuel Pump Cartridge - Overhauled Exchange	4 day
2C27-4	2C27-4	Fuel Pump Cartridge - Customer Property Overhaul	4 day
2C37-1	2C37-1	Fuel Pump Cartridge - Customer Property Overhaul	4 day
2C37-2	2C37-2	Fuel Pump - Customer Property Overhaul	4 day
3B7-1	3B7-1	Fuel Pump - Customer Property Overhaul	4 day
RG17020	3B7-4	Fuel Pump - Customer Property Overhaul	4 day
3B7-4	3B7-4	Fuel Pump - Customer Property Overhaul	4 day
630390-503	3B7-4	Fuel Pump - Customer Property Overhaul	4 day
3B7-4	3B7-4	Fuel Pump - Customer Property Overhaul	4 day
3B7-17	3B7-17	Fuel Pump - Customer Property Overhaul	4 day
1171-00-1	1171-00-1	Fuel Pump - Overhauled Exchange	3 day
1184-00-1	1184-00-1	Fuel Pump - Overhauled Exchange	3 day
1184-00-3	1184-00-3	Fuel Pump - Overhauled Exchange	3 day
1296-00-1	1296-00-1	Fuel Pump - Overhauled Exchange	3 day
1420-00-1	1420-00-1	Fuel Pump - Overhauled Exchange	3 day
1429-00-1	1429-00-1	Fuel Pump - Overhauled Exchange	3 day



# Master Parts Cross Reference

Original Part Number	RAPCO Part Number	Description	Availability
1458-00-1	1458-00-1	Fuel Pump - Overhauled Exchange	3 day
1471-00-3	1471-00-3	Fuel Pump - Overhauled Exchange	3 day
1499-00-19	1499-00-19	Fuel Pump - Overhauled Exchange	3 day
1499-00-21	1499-00-21	Fuel Pump - Overhauled Exchange	3 day
1500-00-22	1500-00-22	Fuel Pump - Customer Property Overhaul	Call* 3 day
1500-00-35	1500-00-35	Fuel Pump - Overhauled Exchange	3 day
1500-00-38	1500-00-38	Fuel Pump - Overhauled Exchange	3 day
1500-00-65	1500-00-65	Fuel Pump - Overhauled Exchange	3 day
1500-00-67	1500-00-67	Fuel Pump - Overhauled Exchange	3 day
1515-00-1	1515-00-1	Fuel Pump - Overhauled Exchange	3 day
1521-00-1	1521-00-1	Fuel Pump (2 Speed) - Customer Property Overhaul	Call* 3 day
1521-00-3	1521-00-3	Fuel Pump (2 Speed) - Customer Property Overhaul	Call* 3 day
1816-00-1	1816-00-1	Fuel Pump - Overhauled Exchange	3 day
4140-00	4140-00	Fuel Pump - Overhauled Exchange	3 day
4140-00-1	4140-00-1	Fuel Pump - Overhauled Exchange	3 day
4140-00-7	4140-00-7	Fuel Pump - Overhauled Exchange	3 day
4140-00-11	4140-00-11	Fuel Pump - Overhauled Exchange	3 day
4140-00-15	4140-00-15	Fuel Pump - Overhauled Exchange	3 day
4140-00-17	4140-00-17	Fuel Pump - Overhauled Exchange	3 day
4140-00-17N	4140-00-17N	Fuel Pump - Overhauled Exchange	3 day
4140-00-19A	4140-00-19A	Fuel Pump - Overhauled Exchange	3 day
4140-00-21A	4140-00-21A	Fuel Pump - Overhauled Exchange	3 day
4140-00-39	4140-00-39	Fuel Pump - Overhauled Exchange	3 day
4140-00-47	4140-00-47	Fuel Pump - Overhauled Exchange	3 day
4140-00-57	4140-00-57	Fuel Pump - Overhauled Exchange	3 day
4140-00-103	4140-00-103	Fuel Pump - Overhauled Exchange	3 day
4140-00-153	4140-00-153	Fuel Pump - Overhauled Exchange	3 day
4140-00-191	4140-00-191	Fuel Pump - Overhauled Exchange	3 day
4140-00-218	4140-00-218	Fuel Pump - Overhauled Exchange	3 day
4140-00-220	4140-00-220	Fuel Pump - Overhauled Exchange	3 day
4140-00-301	4140-00-301	Fuel Pump - Overhauled Exchange	3 day
4140-00-311	4140-00-311	Fuel Pump - Overhauled Exchange	3 day
4150-00	4150-00	Fuel Pump (2 Speed) - Customer Property Overhaul	Call* 3 day
4150-00-1	4150-00-1	Fuel Pump (2 Speed) - Customer Property Overhaul	Call* 3 day
4258-00-15	4258-00-15	Fuel Pump - Overhaul Exchange	3 day
4404-00-7	4404-00-7	Fuel Pump (2 Speed) - Overhauled Exchange	3 day
4404-00-8	4404-00-8	Fuel Pump (2 Speed) - Overhauled Exchange	3 day
4613-00-1	4613-00-1	Fuel Pump (2 Speed) - Overhauled Exchange	3 day
4613-00-3	4613-00-3	Fuel Pump (2 Speed) - Overhauled Exchange	3 day
4613-00-5	4613-00-5	Fuel Pump (2 Speed) - Overhauled Exchange	3 day
MS9134-01	AS3491-01	Dry Air Pump Gasket	Normally Stocked
AS3491-01	AS3491-01	Dry Air Pump Gasket	Normally Stocked
LW15486	RALW15486	Exhaust Gasket	Normally Stocked
971	RALW15486	Exhaust Gasket	Normally Stocked
SL15486	RALW15486	Exhaust Gasket	Normally Stocked
627429	RA627429	Exhaust Gasket	Normally Stocked
SA627429	RA627429	Exhaust Gasket	Normally Stocked
652459	RA627429	Exhaust Gasket	Normally Stocked
649428	RA627429	Exhaust Gasket	Normally Stocked
628260	RA628260	Exhaust Gasket	Normally Stocked
158	RA628260	Exhaust Gasket	Normally Stocked
652458	RA628260	Exhaust Gasket	Normally Stocked
629427	RA628260	Exhaust Gasket	Normally Stocked
628261	RA628260	Exhaust Gasket	Normally Stocked
537379	RA628260	Exhaust Gasket	Normally Stocked
630365	RA630365	Exhaust Gasket	Normally Stocked
SA630365	RA630365	Exhaust Gasket	Normally Stocked
632837	RA632837	Exhaust Gasket	Normally Stocked
21493	RA632837	Exhaust Gasket	Normally Stocked
157	RA632837	Exhaust Gasket	Normally Stocked
SA632837	RA632837	Exhaust Gasket	Normally Stocked
SA636465	RA636465	Turbocharger Wastegate Gasket	Normally Stocked
636465	RA636465	Turbocharger Wastegate Gasket	Normally Stocked
632884	RA636465	Turbocharger Wastegate Gasket	Normally Stocked
75118	RA75118	Exhaust Gasket	Normally Stocked
73720	RA75118	Exhaust Gasket	Normally Stocked
67196	RA75118	Exhaust Gasket	Normally Stocked
65321	RA75118	Exhaust Gasket	Normally Stocked
61259	RA75118	Exhaust Gasket	Normally Stocked



# Master Parts Cross Reference

Original Part Number	RAPCO Part Number	Description	Availability
160	RA75118	Exhaust Gasket	Normally Stocked
77611	RA77611	Exhaust Gasket	Normally Stocked
SL77611	RA77611	Exhaust Gasket	Normally Stocked
3503	RA985	Exhaust Gasket	Normally Stocked
RA215CC	RAP215CC	Dry Air Pump	Normally Stocked
215CC	RAP215CC	Dry Air Pump	Normally Stocked
211CC	RAP215CC	Dry Air Pump	Normally Stocked
211CC	211CC	Dry Air Pump	Normally Stocked
E211CC	RAP215CC	Dry Air Pump	Normally Stocked
203CC	RAP215CC	Dry Air Pump	Normally Stocked
201CC	RAP215CC	Dry Air Pump	Normally Stocked
200CC	RAP215CC	Dry Air Pump	Normally Stocked
AA3215CC	RAP215CC	Dry Air Pump	Normally Stocked
AA215CC	RAP215CC	Dry Air Pump	Normally Stocked
AA211CC	RAP215CC	Dry Air Pump	Normally Stocked
92-410-911	RAP215CC	Dry Air Pump	Normally Stocked
92-410-795	RAP215CC	Dry Air Pump	Normally Stocked
J470280C	RAP215CC	Dry Air Pump	Normally Stocked
C431004-0101	RAP215CC	Dry Air Pump	Normally Stocked
C431004-0201	RAP215CC	Dry Air Pump	Normally Stocked
C431002-0101	RAP215CC	Dry Air Pump	Normally Stocked
481764PLH	RAP215CC	Dry Air Pump	Normally Stocked
481753VRB	RAP215CC	Dry Air Pump	Normally Stocked
26749-007	RAP215CC	Dry Air Pump	Normally Stocked
481-738	RAP215CC	Dry Air Pump	Normally Stocked
481-692	RAP215CC	Dry Air Pump	Normally Stocked
RA215CC-9	RAP215CC-9	Dry Air Pump	Normally Stocked
215CC-9	RAP215CC-9	Dry Air Pump	Normally Stocked
211CC-9	RAP215CC-9	Dry Air Pump	Normally Stocked
200CC-9	RAP215CC-9	Dry Air Pump	Normally Stocked
AA3215CC-9	RAP215CC-9	Dry Air Pump	Normally Stocked
AA3225CC-9	RAP215CC-9	Dry Air Pump	Normally Stocked
AA215CC-9	RAP215CC-9	Dry Air Pump	Normally Stocked
AA211CC-9	RAP215CC-9	Dry Air Pump	Normally Stocked
C431003-0103	RAP215CC-9	Dry Air Pump	Normally Stocked
C431002-0102	RAP215CC-9	Dry Air Pump	Normally Stocked
RA216CW	RAP216CW	Dry Air Pump	Normally Stocked
216CW	RAP216CW	Dry Air Pump	Normally Stocked
212CW	RAP216CW	Dry Air Pump	Normally Stocked
E212CW	RAP216CW	Dry Air Pump	Normally Stocked
204CW	RAP216CW	Dry Air Pump	Normally Stocked
200CW	RAP216CW	Dry Air Pump	Normally Stocked
AA3226CW	RAP216CW	Dry Air Pump	Normally Stocked
AA3216CW	RAP216CW	Dry Air Pump	Normally Stocked
AA216CW	RAP216CW	Dry Air Pump	Normally Stocked
AA212CW	RAP216CW	Dry Air Pump	Normally Stocked
92-410-908	RAP216CW	Dry Air Pump	Normally Stocked
J470281	RAP216CW	Dry Air Pump	Normally Stocked
C431003-0102	RAP216CW	Dry Air Pump	Normally Stocked
C431004-0202	RAP216CW	Dry Air Pump	Normally Stocked
C431002-0103	RAP216CW	Dry Air Pump	Normally Stocked
481765PLH	RAP216CW	Dry Air Pump	Normally Stocked
481754VRB	RAP216CW	Dry Air Pump	Normally Stocked
26749-008	RAP216CW	Dry Air Pump	Normally Stocked
481-732	RAP216CW	Dry Air Pump	Normally Stocked
216CW	RAP216CW	Dry Air Pump	Normally Stocked
RA241CC	RAP241CC	Dry Air Pump	Normally Stocked
241CC	RAP241CC	Dry Air Pump	Normally Stocked
231CC	RAP241CC	Dry Air Pump	Normally Stocked
AA241CC	RAP241CC	Dry Air Pump	Normally Stocked
RA241CC-13	RAP241CC-13	Dry Air Pump	Normally Stocked
241CC-13	RAP241CC-13	Dry Air Pump	Normally Stocked
AA241CC-13	RAP241CC-13	Dry Air Pump	Normally Stocked
RA241CC-15	RAP241CC-15	Dry Air Pump	Normally Stocked
241CC-15	RAP241CC-15	Dry Air Pump	Normally Stocked
AA241CC-15	RAP241CC-15	Dry Air Pump	Normally Stocked
RA242CW	RAP242CW	Dry Air Pump	Normally Stocked
242CW	RAP242CW	Dry Air Pump	Normally Stocked
232CW	RAP242CW	Dry Air Pump	Normally Stocked



# Master Parts Cross Reference

Original Part Number	RAPCO Part Number	Description	Availability
AA242CW	RAP242CW	Dry Air Pump	Normally Stocked
92-414-844	RAP242CW	Dry Air Pump	Normally Stocked
92-411-500	RAP242CW	Dry Air Pump	Normally Stocked
RA242CW-4	RAP242CW-4	Dry Air Pump	Normally Stocked
242CW-4	RAP242CW-4	Dry Air Pump	Normally Stocked
AA242CW-4	RAP242CW-4	Dry Air Pump	Normally Stocked
92-414-845	RAP242CW-4	Dry Air Pump	Normally Stocked
RA242CW-10	RAP242CW-10	Dry Air Pump	Normally Stocked
242CW-10	RAP242CW-10	Dry Air Pump	Normally Stocked
AA242CW-10	RAP242CW-10	Dry Air Pump	Normally Stocked
RA441CC	RAP441CC	Dry Air Pump	Normally Stocked
441CC	RAP441CC	Dry Air Pump	Normally Stocked
431CC	RAP441CC	Dry Air Pump	Normally Stocked
92-428-126	RAP441CC	Dry Air Pump	Normally Stocked
C431004-0101	RAP441CC	Dry Air Pump	Normally Stocked
J470200	RAP441CC	Dry Air Pump	Normally Stocked
RA441CC-3	RAP441CC-3	Dry Air Pump	Normally Stocked
441CC-3	RAP441CC-3	Dry Air Pump	Normally Stocked
AA441CC-3	RAP441CC-3	Dry Air Pump	Normally Stocked
RA441CC-7	RAP441CC-7	Dry Air Pump	Normally Stocked
441CC-7	RAP441CC-7	Dry Air Pump	Normally Stocked
AA441CC-7	RAP441CC-7	Dry Air Pump	Normally Stocked
481-769	RAP441CC-7	Dry Air Pump	Normally Stocked
431CC-7	RAP441CC-7	Dry Air Pump	Normally Stocked
481-777	RAP441CC-7	Dry Air Pump	Normally Stocked
26740-009	RAP441CC-7	Dry Air Pump	Normally Stocked
481-720	RAP441CC-7	Dry Air Pump	Normally Stocked
RA441CC-9	RAP441CC-9	Dry Air Pump	Normally Stocked
441CC-9	RAP441CC-9	Dry Air Pump	Normally Stocked
431CC-9	RAP441CC-9	Dry Air Pump	Normally Stocked
AA441CC-9	RAP441CC-9	Dry Air Pump	Normally Stocked
92-428-131	RAP441CC-9	Dry Air Pump	Normally Stocked
92-428-121	RAP441CC-9	Dry Air Pump	Normally Stocked
RA441CC-17	RAP441CC-17	Dry Air Pump	Normally Stocked
441CC-17	RAP441CC-17	Dry Air Pump	Normally Stocked
481-811	RAP441CC-17	Dry Air Pump	Normally Stocked
RA441CC-23	RAP441CC-23	Dry Air Pump	Normally Stocked
441CC-23	RAP441CC-23	Dry Air Pump	Normally Stocked
RA442CW	RAP442CW	Dry Air Pump	Normally Stocked
442CW	RAP442CW	Dry Air Pump	Normally Stocked
432CW	RAP442CW	Dry Air Pump	Normally Stocked
AA442CW	RAP442CW	Dry Air Pump	Normally Stocked
92-428-122	RAP442CW	Dry Air Pump	Normally Stocked
92-428-127	RAP442CW	Dry Air Pump	Normally Stocked
J470177	RAP442CW	Dry Air Pump	Normally Stocked
RA442CW-4	RAP442CW-4	Dry Air Pump	Normally Stocked
442CW-4	RAP442CW-4	Dry Air Pump	Normally Stocked
AA442CW-4	RAP442CW-4	Dry Air Pump	Normally Stocked
92-428-129	RAP442CW-4	Dry Air Pump	Normally Stocked
RA442CW-6	RAP442CW-6	Dry Air Pump	Normally Stocked
442CW-6	RAP442CW-6	Dry Air Pump	Normally Stocked
432CW-6	RAP442CW-6	Dry Air Pump	Normally Stocked
AA442CW-6	RAP442CW-6	Dry Air Pump	Normally Stocked
481-770	RAP442CW-6	Dry Air Pump	Normally Stocked
26749-010	RAP442CW-6	Dry Air Pump	Normally Stocked
481-742	RAP442CW-6	Dry Air Pump	Normally Stocked
481-778	RAP442CW-6	Dry Air Pump	Normally Stocked
RA442CW-8	RAP442CW-8	Dry Air Pump	Normally Stocked
442CW-8	RAP442CW-8	Dry Air Pump	Normally Stocked
432CW-8	RAP442CW-8	Dry Air Pump	Normally Stocked
AA442CW-8	RAP442CW-8	Dry Air Pump	Normally Stocked
C431004-0102	RAP442CW-8	Dry Air Pump	Normally Stocked
C431004-012	RAP442CW-8	Dry Air Pump	Normally Stocked
RA442CW-12	RAP442CW-12	Dry Air Pump	Normally Stocked
442CW-12	RAP442CW-12	Dry Air Pump	Normally Stocked
432CW-12	RAP442CW-12	Dry Air Pump	Normally Stocked
AA442CW-12	RAP442CW-12	Dry Air Pump	Normally Stocked
92-428-128	RAP442CW-12	Dry Air Pump	Normally Stocked
RA442CW-14	RAP442CW-14	Dry Air Pump	Normally Stocked



# Master Parts Cross Reference

Original Part Number	RAPCO Part Number	Description	Availability
442CW-14	RAP442CW-14	Dry Air Pump	Normally Stocked
AA442CW-14	RAP442CW-14	Dry Air Pump	Normally Stocked
92-428-132	RAP442CW-14	Dry Air Pump	Normally Stocked
RA442CW-20	RAP442CW-20	Dry Air Pump	Normally Stocked
442CW-20	RAP442CW-20	Dry Air Pump	Normally Stocked
AA442CW-20	RAP442CW-20	Dry Air Pump	Normally Stocked
481-841	RAP442CW-20	Dry Air Pump	Normally Stocked
211CC	RAP215CC-OH	Dry Air Pump Overhauled Exchange	Normally Stocked
211CC-9	211CC-9	Dry Air Pump Customer Property Overhaul	Normally Stocked
212CW	212CW	Dry Air Pump Overhauled Exchange	Normally Stocked
212CW-6	212CW-6	Dry Air Pump Customer Property Overhaul (Call)	CPO (Call) 1 Day
RA215CC	RAP215CC-OH	Dry Air Pump Overhauled Exchange	Normally Stocked
215CC	RAP215CC-OH	Dry Air Pump Overhauled Exchange	Normally Stocked
E211CC	211CC	Dry Air Pump Overhauled Exchange	Normally Stocked
203CC	211CC	Dry Air Pump Overhauled Exchange	Normally Stocked
201CC	211CC	Dry Air Pump Overhauled Exchange	Normally Stocked
200CC	211CC	Dry Air Pump Overhauled Exchange	Normally Stocked
AA3215CC	RAP215CC-OH	Dry Air Pump Overhauled Exchange	Normally Stocked
AA215CC	RAP215CC-OH	Dry Air Pump Overhauled Exchange	Normally Stocked
AA211CC	RAP215CC-OH	Dry Air Pump Overhauled Exchange	Normally Stocked
92-410-911	RAP215CC-OH	Dry Air Pump Overhauled Exchange	Normally Stocked
92-410-795	RAP215CC-OH	Dry Air Pump Overhauled Exchange	Normally Stocked
J470280C	RAP215CC-OH	Dry Air Pump Overhauled Exchange	Normally Stocked
C431004-0101	RAP215CC-OH	Dry Air Pump Overhauled Exchange	Normally Stocked
C431004-0201	RAP215CC-OH	Dry Air Pump Overhauled Exchange	Normally Stocked
C431002-0101	RAP215CC-OH	Dry Air Pump Overhauled Exchange	Normally Stocked
481764PLH	RAP215CC-OH	Dry Air Pump Overhauled Exchange	Normally Stocked
481753VRB	RAP215CC-OH	Dry Air Pump Overhauled Exchange	Normally Stocked
26749-007	RAP215CC-OH	Dry Air Pump Overhauled Exchange	Normally Stocked
481-738	RAP215CC-OH	Dry Air Pump Overhauled Exchange	Normally Stocked
481-692	RAP215CC-OH	Dry Air Pump Overhauled Exchange	Normally Stocked
RA215CC-9	RAP215CC-9-OH	Dry Air Pump Overhauled Exchange	Normally Stocked
215CC-9	RAP215CC-9-OH	Dry Air Pump Overhauled Exchange	Normally Stocked
211CC-9	RAP215CC-9-OH	Dry Air Pump Overhauled Exchange	Normally Stocked
200CC-9	RAP215CC-9-OH	Dry Air Pump Overhauled Exchange	Normally Stocked
AA3215CC-9	RAP215CC-9-OH	Dry Air Pump Overhauled Exchange	Normally Stocked
AA3225CC-9	RAP215CC-9-OH	Dry Air Pump Overhauled Exchange	Normally Stocked
AA215CC-9	RAP215CC-9-OH	Dry Air Pump Overhauled Exchange	Normally Stocked
AA211CC-9	RAP215CC-9-OH	Dry Air Pump Overhauled Exchange	Normally Stocked
C431003-0103	RAP215CC-9-OH	Dry Air Pump Overhauled Exchange	Normally Stocked
C431002-0102	RAP215CC-9-OH	Dry Air Pump Overhauled Exchange	Normally Stocked
RA216CW	RAP216CW-OH	Dry Air Pump Overhauled Exchange	Normally Stocked
216CW	RAP216CW-OH	Dry Air Pump Overhauled Exchange	Normally Stocked
212CW	RAP216CW-OH	Dry Air Pump Overhauled Exchange	Normally Stocked
E212CW	RAP216CW-OH	Dry Air Pump Overhauled Exchange	Normally Stocked
204CW	RAP216CW-OH	Dry Air Pump Overhauled Exchange	Normally Stocked
200CW	RAP216CW-OH	Dry Air Pump Overhauled Exchange	Normally Stocked
AA3226CW	RAP216CW-OH	Dry Air Pump Overhauled Exchange	Normally Stocked
AA3216CW	RAP216CW-OH	Dry Air Pump Overhauled Exchange	Normally Stocked
AA216CW	RAP216CW-OH	Dry Air Pump Overhauled Exchange	Normally Stocked
AA212CW	RAP216CW-OH	Dry Air Pump Overhauled Exchange	Normally Stocked
92-410-908	RAP216CW-OH	Dry Air Pump Overhauled Exchange	Normally Stocked
J470281	RAP216CW-OH	Dry Air Pump Overhauled Exchange	Normally Stocked
C431003-0102	RAP216CW-OH	Dry Air Pump Overhauled Exchange	Normally Stocked
C431004-0202	RAP216CW-OH	Dry Air Pump Overhauled Exchange	Normally Stocked
C431002-0103	RAP216CW-OH	Dry Air Pump Overhauled Exchange	Normally Stocked
481765PLH	RAP216CW-OH	Dry Air Pump Overhauled Exchange	Normally Stocked
481754VRB	RAP216CW-OH	Dry Air Pump Overhauled Exchange	Normally Stocked
26749-008	RAP216CW-OH	Dry Air Pump Overhauled Exchange	Normally Stocked
481-732	RAP216CW-OH	Dry Air Pump Overhauled Exchange	Normally Stocked
216CW	RAP216CW-OH	Dry Air Pump Overhauled Exchange	Normally Stocked
212CW	RAP216CW-OH	Dry Air Pump Overhauled Exchange	Normally Stocked
RA241CC	RAP241CC-OH	Dry Air Pump Overhauled Exchange	Normally Stocked
241CC	RAP241CC-OH	Dry Air Pump Overhauled Exchange	Normally Stocked
231CC	RAP241CC-OH	Dry Air Pump Overhauled Exchange	Normally Stocked
AA241CC	RAP241CC-OH	Dry Air Pump Overhauled Exchange	Normally Stocked
RA241CC-13	RAP241CC-13-OH	Dry Air Pump Overhauled Exchange	Normally Stocked
241CC-13	RAP241CC-13-OH	Dry Air Pump Overhauled Exchange	Normally Stocked
AA241CC-13	RAP241CC-13-OH	Dry Air Pump Overhauled Exchange	Normally Stocked



# Master Parts Cross Reference

Original Part Number	RAPCO Part Number	Description	Availability
RA241CC-15	RAP241CC-15-OH	Dry Air Pump Overhauled Exchange	Normally Stocked
241CC-15	RAP241CC-15-OH	Dry Air Pump Overhauled Exchange	Normally Stocked
AA241CC-15	RAP241CC-15-OH	Dry Air Pump Overhauled Exchange	Normally Stocked
RA242CW	RAP242CW-OH	Dry Air Pump Overhauled Exchange	Normally Stocked
242CW	RAP242CW-OH	Dry Air Pump Overhauled Exchange	Normally Stocked
232CW	RAP242CW-OH	Dry Air Pump Overhauled Exchange	Normally Stocked
AA242CW	RAP242CW-OH	Dry Air Pump Overhauled Exchange	Normally Stocked
92-414-844	RAP242CW-OH	Dry Air Pump Overhauled Exchange	Normally Stocked
92-411-500	RAP242CW-OH	Dry Air Pump Overhauled Exchange	Normally Stocked
RA242CW-4	RAP242CW-4-OH	Dry Air Pump Overhauled Exchange	Normally Stocked
242CW-4	RAP242CW-4-OH	Dry Air Pump Overhauled Exchange	Normally Stocked
AA242CW-4	RAP242CW-4-OH	Dry Air Pump Overhauled Exchange	Normally Stocked
92-414-845	RAP242CW-4-OH	Dry Air Pump Overhauled Exchange	Normally Stocked
RA242CW-10	RAP242CW-10-OH	Dry Air Pump Overhauled Exchange	Normally Stocked
242CW-10	RAP242CW-10-OH	Dry Air Pump Overhauled Exchange	Normally Stocked
AA242CW-10	RAP242CW-10-OH	Dry Air Pump Overhauled Exchange	Normally Stocked
RA441CC	RAP441CC-OH	Dry Air Pump Overhauled Exchange	Normally Stocked
441CC	RAP441CC-OH	Dry Air Pump Overhauled Exchange	Normally Stocked
431CC	RAP441CC-OH	Dry Air Pump Overhauled Exchange	Normally Stocked
92-428-126	RAP441CC-OH	Dry Air Pump Overhauled Exchange	Normally Stocked
C431004-0101	RAP441CC-OH	Dry Air Pump Overhauled Exchange	Normally Stocked
J470200	RAP441CC-OH	Dry Air Pump Overhauled Exchange	Normally Stocked
RA441CC-3	RAP441CC-3-OH	Dry Air Pump Overhauled Exchange	Normally Stocked
441CC-3	RAP441CC-3-OH	Dry Air Pump Overhauled Exchange	Normally Stocked
AA441CC-3	RAP441CC-3-OH	Dry Air Pump Overhauled Exchange	Normally Stocked
RA441CC-7	RAP441CC-7-OH	Dry Air Pump Overhauled Exchange	Normally Stocked
441CC-7	RAP441CC-7-OH	Dry Air Pump Overhauled Exchange	Normally Stocked
AA441CC-7	RAP441CC-7-OH	Dry Air Pump Overhauled Exchange	Normally Stocked
481-769	RAP441CC-7-OH	Dry Air Pump Overhauled Exchange	Normally Stocked
431CC-7	RAP441CC-7-OH	Dry Air Pump Overhauled Exchange	Normally Stocked
481-777	RAP441CC-7-OH	Dry Air Pump Overhauled Exchange	Normally Stocked
26740-009	RAP441CC-7-OH	Dry Air Pump Overhauled Exchange	Normally Stocked
481-720	RAP441CC-7-OH	Dry Air Pump Overhauled Exchange	Normally Stocked
RA441CC-9	RAP441CC-9-OH	Dry Air Pump Overhauled Exchange	Normally Stocked
441CC-9	RAP441CC-9-OH	Dry Air Pump Overhauled Exchange	Normally Stocked
431CC-9	RAP441CC-9-OH	Dry Air Pump Overhauled Exchange	Normally Stocked
AA441CC-9	RAP441CC-9-OH	Dry Air Pump Overhauled Exchange	Normally Stocked
92-428-131	RAP441CC-9-OH	Dry Air Pump Overhauled Exchange	Normally Stocked
92-428-121	RAP441CC-9-OH	Dry Air Pump Overhauled Exchange	Normally Stocked
RA441CC-17	RAP441CC-17-OH	Dry Air Pump Overhauled Exchange	Normally Stocked
441CC-17	RAP441CC-17-OH	Dry Air Pump Overhauled Exchange	Normally Stocked
481-811	RAP441CC-17-OH	Dry Air Pump Overhauled Exchange	Normally Stocked
RA441CC-23	RAP441CC-23-OH	Dry Air Pump Overhauled Exchange	Normally Stocked
441CC-23	RAP441CC-23-OH	Dry Air Pump Overhauled Exchange	Normally Stocked
RA442CW	RAP442CW-OH	Dry Air Pump Overhauled Exchange	Normally Stocked
442CW	RAP442CW-OH	Dry Air Pump Overhauled Exchange	Normally Stocked
432CW	RAP442CW-OH	Dry Air Pump Overhauled Exchange	Normally Stocked
AA442CW	RAP442CW-OH	Dry Air Pump Overhauled Exchange	Normally Stocked
92-428-122	RAP442CW-OH	Dry Air Pump Overhauled Exchange	Normally Stocked
92-428-127	RAP442CW-OH	Dry Air Pump Overhauled Exchange	Normally Stocked
J470177	RAP442CW-OH	Dry Air Pump Overhauled Exchange	Normally Stocked
RA442CW-4	RAP442CW-4-OH	Dry Air Pump Overhauled Exchange	Normally Stocked
442CW-4	RAP442CW-4-OH	Dry Air Pump Overhauled Exchange	Normally Stocked
AA442CW-4	RAP442CW-4-OH	Dry Air Pump Overhauled Exchange	Normally Stocked
92-428-129	RAP442CW-4-OH	Dry Air Pump Overhauled Exchange	Normally Stocked
RA442CW-6	RAP442CW-6-OH	Dry Air Pump Overhauled Exchange	Normally Stocked
442CW-6	RAP442CW-6-OH	Dry Air Pump Overhauled Exchange	Normally Stocked
432CW-6	RAP442CW-6-OH	Dry Air Pump Overhauled Exchange	Normally Stocked
AA442CW-6	RAP442CW-6-OH	Dry Air Pump Overhauled Exchange	Normally Stocked
481-770	RAP442CW-6-OH	Dry Air Pump Overhauled Exchange	Normally Stocked
26749-010	RAP442CW-6-OH	Dry Air Pump Overhauled Exchange	Normally Stocked
481-742	RAP442CW-6-OH	Dry Air Pump Overhauled Exchange	Normally Stocked
481-778	RAP442CW-6-OH	Dry Air Pump Overhauled Exchange	Normally Stocked
RA442CW-8	RAP442CW-8-OH	Dry Air Pump Overhauled Exchange	Normally Stocked
442CW-8	RAP442CW-8-OH	Dry Air Pump Overhauled Exchange	Normally Stocked
432CW-8	RAP442CW-8-OH	Dry Air Pump Overhauled Exchange	Normally Stocked
AA442CW-8	RAP442CW-8-OH	Dry Air Pump Overhauled Exchange	Normally Stocked
C431004-0102	RAP442CW-8-OH	Dry Air Pump Overhauled Exchange	Normally Stocked
C431004-012	RAP442CW-8-OH	Dry Air Pump Overhauled Exchange	Normally Stocked



# Master Parts Cross Reference

Original Part Number	RAPCO Part Number	Description	Availability
RA442CW-12	RAP442CW-12-OH	Dry Air Pump Overhauled Exchange	Normally Stocked
442CW-12	RAP442CW-12-OH	Dry Air Pump Overhauled Exchange	Normally Stocked
432CW-12	RAP442CW-12-OH	Dry Air Pump Overhauled Exchange	Normally Stocked
AA442CW-12	RAP442CW-12-OH	Dry Air Pump Overhauled Exchange	Normally Stocked
92-428-128	RAP442CW-12-OH	Dry Air Pump Overhauled Exchange	Normally Stocked
RA442CW-14	RAP442CW-14-OH	Dry Air Pump Overhauled Exchange	Normally Stocked
442CW-14	RAP442CW-14-OH	Dry Air Pump Overhauled Exchange	Normally Stocked
AA442CW-14	RAP442CW-14-OH	Dry Air Pump Overhauled Exchange	Normally Stocked
92-428-132	RAP442CW-14-OH	Dry Air Pump Overhauled Exchange	Normally Stocked
RA442CW-20	RAP442CW-20-OH	Dry Air Pump Overhauled Exchange	Normally Stocked
442CW-20	RAP442CW-20-OH	Dry Air Pump Overhauled Exchange	Normally Stocked
AA442CW-20	RAP442CW-20-OH	Dry Air Pump Overhauled Exchange	Normally Stocked
481-841	RAP442CW-20-OH	Dry Air Pump Overhauled Exchange	Normally Stocked
AA716	RA716	Wrench 7/16 - Dry Air Pump	Normally Stocked
82-00067	RA03-002	Shear Shaft/Coupler	Normally Stocked
82-06768	RA-SHEAR COUPLER KIT	Shear Coupler Service Kit	Normally Stocked
82-501222A6TK	RA- VAC MEASURE KIT	Dry Air Pump Inspection Kit	Normally Stocked
1H5-1	RA1H5-1	Manifold Check Valve - New	Normally Stocked
1J10-1	RA1J10-1	Central Air Filter Assembly	Normally Stocked
C294502-0101	RA1J10-1	Central Air Filter Assembly	Normally Stocked
1J4-4	RA2J4-4	Inline Air Filter	Normally Stocked
2J4-4	RA2J4-4	Inline Air Filter	Normally Stocked
AA1J4-4	RA2J4-4	Inline Air Filter	Normally Stocked
AA2J4-4	RA2J4-4	Inline Air Filter	Normally Stocked
RA1J4-4	RA2J4-4	Inline Air Filter	Normally Stocked
200441	RA2J4-4	Inline Air Filter	Normally Stocked
201442	RA2J4-4	Inline Air Filter	Normally Stocked
J-158444	RA2J4-4	Inline Air Filter	Normally Stocked
460-857	RA2J4-4	Inline Air Filter	Normally Stocked
460-888	RA2J4-4	Inline Air Filter	Normally Stocked
1J4-6	RA2J4-6	Inline Air Filter	Normally Stocked
2J4-6	RA2J4-6	Inline Air Filter	Normally Stocked
AA1J4-6	RA2J4-6	Inline Air Filter	Normally Stocked
AA2J4-6	RA2J4-6	Inline Air Filter	Normally Stocked
RA1J4-6	RA2J4-6	Inline Air Filter	Normally Stocked
92-301-126	RA2J4-6	Inline Air Filter	Normally Stocked
460-866	RA2J4-6	Inline Air Filter	Normally Stocked
560-689	RA2J4-6	Inline Air Filter	Normally Stocked
1J4-7	RA2J4-7	Inline Air Filter	Normally Stocked
2J4-7	RA2J4-7	Inline Air Filter	Normally Stocked
AA1J4-7	RA2J4-7	Inline Air Filter	Normally Stocked
AA2J4-7	RA2J4-7	Inline Air Filter	Normally Stocked
RA1J4-7	RA2J4-7	Inline Air Filter	Normally Stocked
92-301-127	RA2J4-7	Inline Air Filter	Normally Stocked
101-524009-0163	RA101-524009-0163	Rudder Boost Filter	Normally Stocked
101-524009-0161	RA101-524009-0163	Rudder Boost Filter	Normally Stocked
101-524009-91	RA101-524009-0163	Rudder Boost Filter	Normally Stocked
B3-5-1	RA-B3-5-1	Garter Filter Element	Normally Stocked
B3005A1	RA-B3-5-1	Garter Filter Element	Normally Stocked
AA3-5-1	RA-B3-5-1	Garter Filter Element	Normally Stocked
C482001-0202	RA-B3-5-1	Garter Filter Element	Normally Stocked
751-815	RA-B3-5-1	Garter Filter Element	Normally Stocked
D9-14-3	RA-D9-14-3	Inlet Air Filter Element	Normally Stocked
AAD9-14-3	RA-D9-14-3	Inlet Air Filter Element	Normally Stocked
D9-14-5	RA-D-9-14-5	Inlet Air Filter Element	Normally Stocked
AAD9-14-5	RA-D-9-14-5	Inlet Air Filter Element	Normally Stocked
8398136-05-OH	RA-D-9-14-5	Inlet Air Filter Element	Normally Stocked
C294501-0103	RA-D-9-14-5	Inlet Air Filter Element	Normally Stocked
757-899	RA-D-9-14-5	Inlet Air Filter Element	Normally Stocked
D9-18-1	RA-D9-18-1	Inlet Air Filter Element	Normally Stocked
AAD9-18-1	RA-D9-18-1	Inlet Air Filter Element	Normally Stocked
C294502-0201	RA-D9-18-1	Inlet Air Filter Element	Normally Stocked
J518317	RA-D9-18-1	Inlet Air Filter Element	Normally Stocked
757-899	RA-D9-18-1	Inlet Air Filter Element	Normally Stocked
1K1-4-6	RA1K1-4-6	Pneumatic Instrument Fitting	Normally Stocked
134A3	RA1K1-4-6	Pneumatic Instrument Fitting	Normally Stocked
AA1K1-4-6	RA1K1-4-6	Pneumatic Instrument Fitting	Normally Stocked
458-945	RA1K1-4-6	Pneumatic Instrument Fitting	Normally Stocked
1K1-6-10	RA1K1-6-10	Pneumatic Pump Fitting	Normally Stocked



# Master Parts Cross Reference

Original Part Number	RAPCO Part Number	Description	Availability
AA1K1-6-10	RA1K1-6-10	Pneumatic Pump Fitting	Normally Stocked
458-958	RA1K1-6-10	Pneumatic Pump Fitting	Normally Stocked
1K8-6-10	RA1K8-6-10	Pneumatic Pump Fitting	Normally Stocked
AA1K8-6-10	RA1K8-6-10	Pneumatic Pump Fitting	Normally Stocked
560-810	RA1K8-6-10	Pneumatic Pump Fitting	Normally Stocked
1K10-4-6	RA1K10-4-6	Pneumatic Instrument Fitting	Normally Stocked
AA1K10-4-6	RA1K10-4-6	Pneumatic Instrument Fitting	Normally Stocked
451-939	RA1K10-4-6	Pneumatic Instrument Fitting	Normally Stocked
1K10-6-10	RA1K10-6-10	Pneumatic Pump Fitting	Normally Stocked
AA1K10-6-10	RA1K10-6-10	Pneumatic Pump Fitting	Normally Stocked
1K31-4-6-4	RA1K31-4-6-4	Pneumatic Instrument Fitting	Normally Stocked
AA1K31-4-6-4	RA1K31-4-6-4	Pneumatic Instrument Fitting	Normally Stocked
560-835	RA1K31-4-6-4	Pneumatic Instrument Fitting	Normally Stocked
2H3-2	RA2H3-2	Pneumatic Vacuum Regulator	Normally Stocked
133A3	RA2H3-2	Pneumatic Vacuum Regulator	Normally Stocked
AA2H3-2	RA2H3-2	Pneumatic Vacuum Regulator	Normally Stocked
C482001-0101	RA2H3-2	Pneumatic Vacuum Regulator	Normally Stocked
2H3-5	RA2H3-5	Pneumatic Vacuum Regulator	Normally Stocked
133C1	RA2H3-5	Pneumatic Vacuum Regulator	Normally Stocked
AA2H3-5	RA2H3-5	Pneumatic Vacuum Regulator	Normally Stocked
2H3-6	RA2H3-6	Pneumatic Vacuum Regulator	Normally Stocked
133B3	RA2H3-6	Pneumatic Vacuum Regulator	Normally Stocked
AA2H3-6	RA2H3-6	Pneumatic Vacuum Regulator	Normally Stocked
584-324	RA2H3-6	Pneumatic Vacuum Regulator	Normally Stocked
2H3-11	RA2H3-11	Pneumatic Vacuum Regulator	Normally Stocked
2H3-12	RA2H3-12	Pneumatic Vacuum Regulator	Normally Stocked
2H3-16	RA2H3-12	Pneumatic Vacuum Regulator	Normally Stocked
133A16	RA2H3-12	Pneumatic Vacuum Regulator	Normally Stocked
AA2H3-12	RA2H3-12	Pneumatic Vacuum Regulator	Normally Stocked





**RAPCO, inc.**

**REPLACEMENT AIRCRAFT PARTS CO.**



Rapco, Inc.  
445 Cardinal Lane  
Hartland, WI 53029  
262.367.2292 phone  
262.367.7158 fax  
[www.rapcoinc.com](http://www.rapcoinc.com)